

# Operator Manual

For printer model:

# SG112 **ex**

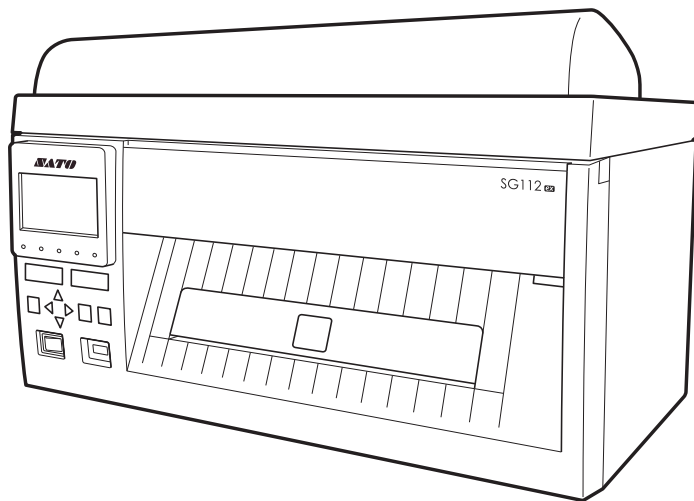

## **Copyrights**

Any unauthorized reproduction of the contents of this document, in part or whole, is strictly prohibited.

## **Limitation of Liability**

SATO Corporation and its subsidiaries in Japan, the U.S. and other countries make no representations or warranties of any kind regarding this material, including, but not limited to, implied warranties of merchantability and fitness for a particular purpose. SATO Corporation shall not be held responsible for errors contained herein or any omissions from this material or for any damages, whether direct, indirect, incidental or consequential, in connection with the furnishing, distribution, performance or use of this material.

Specifications and contents in this document are subject to change without notice.

Be sure to perform a virus check on the USB memory or SD card before connecting it to the product. SATO Corporation shall not be held responsible for any product malfunctions caused by a virus spread via USB memory or SD card.

## **Trademarks**

SATO is a registered trademark of SATO Holdings Corporation and its subsidiaries in Japan, the U.S. and other countries.

Secure Digital (SD) Card is a registered trademark of the SD Card Association.

QR Code is a registered trademark of DENSO WAVE INCORPORATED.

Windows is either a registered trademark or trademark of Microsoft Corporation in the United States and/or other countries.

All other trademarks are the property of their respective owners.

**Version: GBS-SG112ex-r01-22-03-19OM**

**© 2019 SATO Corporation. All rights reserved.**

# Table of Contents

<b>Table of Contents .....</b>	<b>1</b>
<b>Before You Start .....</b>	<b>7</b>
Features of the Product .....	7
Safety Precautions .....	8
Precautions for Installation and Handling .....	12
Regulatory Approval .....	13
Support and Warranty .....	16
<b>1 Basic Information .....</b>	<b>17</b>
<b>1.1 Checking the Bundled Accessories .....</b>	<b>17</b>
1.1.1 Installing the Top Cover .....	18
<b>1.2 Optional Devices .....</b>	<b>19</b>
<b>1.3 Parts Identification of the Product .....</b>	<b>20</b>
1.3.1 Front View .....	20
1.3.2 Rear View .....	21
1.3.3 Internal View .....	22
<b>1.4 Parts on the Operator Panel .....</b>	<b>23</b>
1.4.1 Operator Panel .....	23
1.4.2 LED Indicators .....	24
<b>2 Installing the Product .....</b>	<b>25</b>
<b>2.1 Installation Precautions .....</b>	<b>25</b>
<b>2.2 Installation Space .....</b>	<b>26</b>
2.2.1 Front View .....	26
2.2.2 Side View .....	27
<b>2.3 Connecting the Product .....</b>	<b>28</b>
2.3.1 Connecting the Product to a Computer .....	28
2.3.2 Available Interfaces .....	29
2.3.3 USB Interface Connection .....	30
2.3.4 LAN Interface Connection .....	30
2.3.5 IEEE 1284 Interface Connection .....	31
2.3.6 RS-232C Interface Connection .....	31
2.3.7 Interface Settings .....	32
2.3.8 Interface Combination .....	33
2.3.9 EXT External Signal Interface Connection .....	33

<b>2.4 Connecting the Power Cord</b> .....	<b>34</b>
<b>2.5 Power On/Off the Product</b> .....	<b>35</b>
2.5.1 Power On the Product.....	35
2.5.2 Power Off the Product.....	36
<b>2.6 Installing Optional Memory Storage</b> .....	<b>37</b>
2.6.1 Installing the Optional SD Card.....	37
2.6.2 Removing the Optional SD Card.....	38
2.6.3 Installing the Optional USB Memory.....	39
<b>3 Loading the Ribbon and Media</b> .....	<b>41</b>
<b>3.1 Checking the Ink Side of the Ribbon</b> .....	<b>41</b>
<b>3.2 Loading the Ribbon</b> .....	<b>42</b>
<b>3.3 Usable Media</b> .....	<b>46</b>
<b>3.4 Loading Media</b> .....	<b>47</b>
3.4.1 Loading Fan-fold Media.....	47
3.4.2 Loading Media Roll.....	49
3.4.3 Using Cutter.....	50
<b>4 Operation and Configuration</b> .....	<b>51</b>
<b>4.1 Display and Operation</b> .....	<b>51</b>
4.1.1 Normal Mode Display and Icons.....	51
4.1.2 Setting Mode Menu and Icons.....	54
4.1.3 Error Display and Icons.....	55
4.1.4 Setting Display.....	56
<b>4.2 Operating Modes</b> .....	<b>58</b>
4.2.1 Online Mode/Pause Mode/Offline Mode.....	61
4.2.2 Canceling the Print Job.....	63
4.2.3 Adjustment Mode.....	64
4.2.4 Settings Mode Menu.....	66
4.2.5 User Mode.....	68
4.2.6 Interface Mode.....	74
4.2.7 Memory Mode.....	105
4.2.8 Advanced Mode.....	114
4.2.9 Hex Dump Mode.....	125
4.2.10 Information Mode.....	127
4.2.11 Test Print Mode.....	130
4.2.12 Default Setting Mode.....	133
4.2.13 Download Mode.....	135
4.2.14 Upload Mode.....	140



---

<b>5 Adjusting the Product</b> .....	<b>143</b>
<b>5.1 Adjusting the Display Brightness</b> .....	<b>143</b>
<b>5.2 Adjusting the Buzzer Volume</b> .....	<b>144</b>
<b>5.3 LCD Power Saving Mode</b> .....	<b>145</b>
<b>5.4 Adjusting the Base Reference Point</b> .....	<b>146</b>
5.4.1 About the Base Reference Point .....	146
5.4.2 Adjusting the Print Position.....	147
5.4.3 Adjusting the Media Stop Position for Option .....	148
5.4.4 Notes on the Stop/Cut Position of Different Media .....	150
5.4.5 Limitation on Base Reference Point Adjustment .....	151
5.4.6 Changing Backfeed Distance .....	152
<b>5.5 Adjusting the Print Quality</b> .....	<b>155</b>
5.5.1 Adjusting the Print Darkness .....	155
5.5.2 Adjusting the Print Speed .....	156
<b>6 Maintenance</b> .....	<b>159</b>
<b>6.1 Cleaning the Product</b> .....	<b>159</b>
<b>6.2 Cleaning the Print Head and Platen Roller</b> .....	<b>160</b>
6.2.1 Cleaning Intervals.....	160
6.2.2 Cleaning Using the Cleaning Kit.....	160
6.2.3 Cleaning Using the Cleaning Sheet.....	164
<b>7 Troubleshooting</b> .....	<b>167</b>
<b>7.1 When an Error Message Appears</b> .....	<b>167</b>
7.1.1 More Information about Command Error .....	175
7.1.2 More Information about Head Check Function .....	176
<b>7.2 When a Warning Message Appears</b> .....	<b>177</b>
<b>7.3 Troubleshooting</b> .....	<b>180</b>
7.3.1 No Power/Nothing on the Screen .....	180
7.3.2 Cannot Feed the Media .....	180
7.3.3 Can Feed the Media but Cannot Print .....	181
7.3.4 Bad Print Quality.....	182
7.3.5 Incorrect Print Position .....	182
<b>7.4 Interface Troubleshooting</b> .....	<b>184</b>
7.4.1 USB Interface .....	184
7.4.2 LAN Ethernet Interface .....	184
7.4.3 RS-232C Interface .....	184
7.4.4 IEEE1284 Interface .....	185
7.4.5 External Signal Interface (EXT).....	185

<b>8 Appendix .....</b>	<b>187</b>
<b>8.1 List of Initial Values .....</b>	<b>187</b>
8.1.1 Normal Mode .....	187
8.1.2 User Mode .....	187
8.1.3 Interface Mode.....	188
8.1.4 Memory Mode.....	190
8.1.5 Advanced Mode.....	191
8.1.6 Hex Dump Mode.....	192
8.1.7 Test Print Mode .....	192
8.1.8 Default Setting Mode .....	192
<b>8.2 Download and Upload Specification .....</b>	<b>193</b>
<b>8.3 Memory Storage Folder Structure .....</b>	<b>194</b>
<b>8.4 Notification Function .....</b>	<b>196</b>
<b>8.5 Media Sensor Positions and Option Positions .....</b>	<b>198</b>
<b>8.6 Paper End and Ribbon End Detection .....</b>	<b>199</b>
8.6.1 Paper End.....	199
8.6.2 Ribbon End.....	201
<b>8.7 Print Operation .....</b>	<b>202</b>
8.7.1 Continuous Mode, Pitch Sensor Enabled and No Pulse Input (Head Check Disabled) .....	203
8.7.2 Continuous Mode, Pitch Sensor Enabled and No Pulse Input (Head Check Enabled).....	204
8.7.3 Continuous Mode, Pitch Sensor Enabled and Pulse Input (Head Check Disabled) .....	205
8.7.4 Continuous Mode, Pitch Sensor Enabled and Pulse Input (Head Check Enabled).....	206
8.7.5 No Pulse Input in Tear-off Mode (Head Check Disabled) .....	207
8.7.6 No Pulse Input in Tear-off Mode (Head Check Enabled) .....	208
8.7.7 With Pulse Input in Tear-off Mode (Head Check Disabled).....	209
8.7.8 With Pulse Input in Tear-off Mode (Head Check Enabled).....	210
8.7.9 No Backfeed/Pulse Input in Cutter Mode .....	211
8.7.10 No Pulse Input in Motion 1 Cutter Mode.....	212
8.7.11 No Pulse Input in Motion 2 Cutter Mode.....	213
8.7.12 No Pulse Input in Motion 3 Cutter Mode (Head Check Disabled) .....	214
8.7.13 No Pulse Input in Motion 3 Cutter Mode (Head Check Enabled) .....	215
8.7.14 No Backfeed and With Pulse Input in Cutter Mode .....	216
8.7.15 With Pulse Input in Motion 1 Cutter Mode .....	217
8.7.16 With Pulse Input in Motion 2 Cutter Mode .....	218
8.7.17 When Sensor is Disabled .....	219
8.7.18 Additional Notes on Motion 3 Cutting Operation .....	220

---

<b>8.8 Product Specifications .....</b>	<b>221</b>
8.8.1 Hardware .....	221
8.8.2 Ribbon and Media .....	222
8.8.3 Interface.....	223
8.8.4 Built-in Functions .....	224
8.8.5 Printer Languages .....	224
8.8.6 Fonts/Symbols/Barcodes.....	225
8.8.7 Options .....	227
8.8.8 Accessories .....	227
8.8.9 Standards .....	227
<b>8.9 Interface Specifications.....</b>	<b>228</b>
8.9.1 USB Interface .....	229
8.9.2 LAN Interface.....	230
8.9.3 RS-232C Interface.....	232
8.9.4 IEEE1284 Interface .....	234
8.9.5 External Signal Interface (EXT).....	236
8.9.6 USB Host.....	243

**This page is intentionally left blank.**

# Before You Start

Thank you for purchasing the SATO SG112-ex (hereafter referred to as “the product”). This manual supplies basic information on how to operate the SG112-ex. Read the manual carefully to understand each function of the SG112-ex before operation.

---

## Features of the Product

SATO SG112-ex is a high-performance labeling system, specially for large compliance label applications. It has a user-friendly design and equipped with versatile functions.

The main features of SG112-ex are as follows:

- It can print labels as large as 420 x 266.7 mm (16.5” x 10.5”) with a resolution of 305 dpi (dots per inch).
- Automatic media feed via auto feed sensor.
- Equipped with an LCD and five status LEDs for improved monitoring of the product status.
- Durable design for harsh environment.
- High-speed throughput printing with maximum 6 ips (inches per second) print speed.
- Easily upload/download data to/from an SD card or USB memory, or by using the SATO All-In-One Tool application.
- Supports remote printer setting through the SATO All-In-One Tool application.
- Supports a multi-language display menu and printing of Asian fonts.
- Supports various communication interfaces.
- Supports SNTP protocol.

# Safety Precautions

This topic describes how to use the product safely. Be sure to read the following information carefully before using the product.

## Pictographic Symbols

This operator manual and the product labels use a variety of pictographic symbols. These symbols emphasize the safe and correct use of the product and to prevent injury to others and property damage. The explanation of the symbols is as follows. Be sure to understand these symbols well before you read the main text.

 <b>Warning</b>	The Warning symbol indicates that you can cause death or serious injury if you do not follow the instruction or procedure.
---	--

 <b>Caution</b>	The Caution symbol indicates that you can cause injury or property damage if you do not follow the instruction or procedure.
---	--

## Example Pictographs









The  $\triangle$  pictograph means “Caution is required”. A specific warning symbol is contained inside this pictograph (The left symbol is for electric shock).



The  $\odot$  pictograph means “Must not be done”. What is specifically prohibited is contained in or near the pictograph (The left symbol means “Disassembly prohibited”).



The  $\bullet$  pictograph means “Must be done”. What is specifically to be done is contained in the pictograph (The left symbol means “Unplug the power cord from the outlet”).

 <b>Warning</b>	
<p><b>Do not use the voltage other than specified</b></p> <div style="display: flex; align-items: center;">  <ul style="list-style-type: none"> <li>• Do not use the power supply voltage other than the one specified. Doing so could result in a fire or electric shock.</li> </ul> </div> <p><b>Do not use in hazardous locations</b></p> <div style="display: flex; align-items: center;">  <ul style="list-style-type: none"> <li>• The product is not explosion proof certified.</li> <li>• Do not use in a potentially explosive environment or atmosphere. Doing so could result in a fire or explosion.</li> </ul> </div> <p><b>Do not set on an unstable area</b></p> <div style="display: flex; align-items: center;">  <ul style="list-style-type: none"> <li>• Do not set the product on an unstable area, such as a wobbly table or slanted area or on an area subject to strong vibration. The product could fall or topple over, possibly resulting in injury.</li> </ul> </div>	<p><b>When the product is dropped or breaks</b></p> <ul style="list-style-type: none"> <li>• If the product is dropped or breaks, immediately power it off, unplug the power cord from the outlet, and contact your SATO reseller or technical support. Using the product in one of these conditions could result in a fire or electric shock.</li> </ul> <div style="display: flex; flex-direction: column; align-items: center; margin-top: 10px;">    </div>

## ⚠ Warning

### Handling the power cord and other cables



- Do not damage, break, or alter the power cord and other cables. Also, do not place heavy objects on the power cord, apply heat to it, or forcibly bend, twist, or pull it. Doing so could result in a fire or electric shock.
- Do not splash water on the power cord or get it wet. Doing so could result in damage or electric shock.
- If the power cord and other cables become damaged (core is exposed, wires broken, deformed, etc.), contact your SATO reseller or technical support. Using the power cord and other cables in this condition could result in a fire or electric shock.
- The dedicated power cord included in the package is to be used specifically for this product. Do not use it for other electronic products. Also, do not use the power cord of other products for this product. Doing so could result in a fire or electric shock.

### Always ground the connections



- Always connect the product's ground wire to a ground. Not grounding the ground wire could result in electric shock.

### Do not use the product when something is abnormal



- Do not use the product if any abnormality such as smoke or an unusual odor is detected. Doing so could result in a fire or electric shock. Immediately power off the product, unplug the power cord from the outlet, and contact your SATO reseller or technical support for repairs.

### Do not place containers holding water or other liquid near the product



- Do not place flower vases, cups, or other containers holding liquids, such as water or chemicals, near the product. If water or chemicals get inside the product, immediately power it off, and contact your SATO reseller or technical support. Using the product in this condition could result in a fire or electric shock.

### Do not drop the product in water



- Do not use the product near a container holding liquid. If the product is dropped into water, immediately power it off, and contact your SATO reseller or technical support. Using the product in this condition could result in a fire or electric shock.

### Do not put objects inside the product



- Do not insert or drop any metal or flammable objects down the opening (cable port, etc.) of the product. If a foreign object gets inside the product, immediately power it off, unplug the power cord from the outlet, and contact your SATO reseller or technical support. Using the product in this condition could result in a fire or electric shock.

### Connecting cables or optional devices



- Before connecting a cable or optional device to the product, be sure to power off the product and the optional devices. If they are connected with the power on, an optional device could move unexpectedly, resulting in injury, electric shock, or damage.
- When installing a cable or optional device, be sure not to make a mistake in the orientation and steps to install. Otherwise, it could result in injury, fire, electric shock, or damage.
- Do not use cables other than the ones supplied with the product or recommended by us. Doing so could result in smoke, fire, electric shock, or damage.

 **Warning**

**Do not operate with wet hands**



- Do not power on/power off the product or plug/unplug the power cord and other cables with wet hands. Doing so could result in electric shock or damage.



**Do not disassemble the product**



- Do not disassemble or modify the product. Doing so could result in a fire or electric shock. Ask your SATO reseller or technical support to conduct internal inspections, adjustments, and repairs.



**Using the cleaning fluid**



- Do not use cleaning fluids other than the ones supplied with the product or recommended by us.
- The cleaning fluid is to be strictly kept away from the fire. Never apply heat or place it in the fire.
- Keep the fluid out of reach of children to prevent them from accidentally drinking it. If a child accidentally drinks the fluid, immediately consult with a physician.



**Do not touch or insert any object in the cutter**



- Do not touch the cutter with your hands or insert foreign objects other than media into the cutter. Doing so could result in injury.



## ⚠ Caution

### Carrying the product



- Do not carry the product while loaded with media or attached to an optional external device. They could fall, possibly resulting in injury.



- When setting the product on the floor or a stand, make sure not to get your fingers or hands trapped under the product.



- Before moving the product, be sure to power it off, unplug the power cord from the outlet, and disconnect any connected cables. Moving the product with the power cord or cables still connected could damage them, possibly resulting in a fire, electric shock, or damage.

### Do not place the product in areas with high humidity



- Do not place this product in an area with high humidity or where condensation occurs. If condensation has occurred, immediately power off the product, and avoid using it until it is dried. Using the product while condensation is on it could result in a fire, electric shock, or damage.

### Power cord and other cables



- Grab a power cord and other cables by the plug when removing from the outlet or connector port. Removing a power cord and other cables by grabbing the cord/cable area could result in exposure of wires, breakage, fire, electric shock, or damage.



- Do not place the power cord and other cables near a heater or other sources of heat. Doing so could result in melting of the power cord and other cables sheathing, fire, electric shock, or damage.



### Loading fan-fold media



- Be careful not to get injured when handling the media inlet or the cover.

### Loading media roll



- When loading a media roll, be careful not to get your fingers trapped between the media roll and the supply spindle.

### Print head



- The print head is hot after printing. Be careful not to get burned when replacing media or cleaning immediately after printing.



- Do not touch the print head with your bare hands. Doing so could result in injury or damage.



- To replace the print head, follow the procedure in the Operator Manual. If the Operator Manual does not contain this procedure, avoid trying to replace it on your own terms, and contact your SATO reseller or technical support.

- When opening and closing the print head, make sure that objects other than media do not get caught. Otherwise, it could result in injury or damage.

### Cover



- When opening and closing the cover, be careful not to get your fingers trapped in between. Also, firmly hold the cover to prevent it from closing unexpectedly.

### Always keep the cover of the product closed



- Always have the cover of the product closed when using. You could get injured by touching the moving parts. Also, dust or foreign objects could get inside, possibly resulting in the product to malfunction.

### When not using the product for a long time



- When not using the product for a long time, unplug the power cord from the outlet to maintain safety.

### During maintenance and cleaning



- When maintaining and cleaning the product, unplug the power cord from the outlet to maintain safety.

## Precautions for Installation and Handling

Product operations can be affected by the product's environment. Refer to the following instructions regarding how to install and handle the product.

### Select a Safe Location

#### **Place the product on a surface that is flat and level.**

If the surface is not flat and level, this may cause bad print quality. This may also cause a malfunction and decrease the life span of the product.

#### **Do not place the product on a location that produces vibration.**

Subjecting the product to severe vibration or shock may cause a failure or damage to the product, leading to a product malfunction.

#### **Keep the product out of high temperature and humidity.**

Avoid locations subject to extreme or fast changes in temperature or humidity.

#### **Do not install the product in a location exposed to water or oil.**

Water or oil entering inside the product may cause a fire, electric shock or malfunction.

#### **Avoid dust.**

Dust build up may cause lowered print quality, faults, or malfunctions.

#### **Keep out of direct sunlight.**

The product has a built-in optical sensor. Exposure to direct sunlight may cause incorrect detection by the sensor so the product does not operate normally. Therefore, close the cover when using the product.

#### **Do not use in hazardous locations.**

Do not use in a potentially explosive environment or atmosphere. Doing so could cause a fire or explosion.

### Power Supply

#### **The product requires an AC power supply.**

Be sure to connect the product to an AC power supply.

#### **Connect the power cord to a grounded AC outlet.**

Make sure that the product is connected to a grounded AC outlet.

#### **Supply a stable source of electricity to the product.**

When using the product, do not share its AC outlet with other electrical devices. This could cause power fluctuations and performance issues with your product.

### Printing

The print result varies depending on the usage environment (temperature and humidity), the supply condition (the combination of media and ribbon), and the product settings (the print speed, the print darkness, etc.). Please sufficiently test the product in your usage environment, and use it with the optimal combination. If anything is unclear, or if you have any questions, contact your SATO reseller or technical support center.

## Regulatory Approval

### FCC Warning

This equipment has been tested and found to comply with the limits for a Class A digital device, pursuant to Part 15 of the FCC Rules. These limits are designed to provide reasonable protection against harmful interference when the equipment is operated in a commercial environment. This equipment generates, uses, and can radiate radio frequency energy, and if not installed and used in accordance with the instructions, may cause harmful interference to radio communications. Operation of this equipment in a residential area is likely to cause harmful interference in which case the user will be required to correct the interference at his own expense.

### Disposal of Old Electrical & Electronic Equipment (Applicable in the European Union and other European countries with separate collection systems)



A product marked with this symbol on itself or on its packaging shall not be treated as household waste. Instead it shall be handed over to an appropriate collection point for the recycling of electrical and electronic equipment in accordance with local regulations.

Inappropriate waste handling of this product may cause detrimental consequences for the environment and damage to human health. The recycling of materials will help to conserve natural resources and contribute to your community. For more detailed information on recycling of this product, please contact your local municipal organization, your household waste disposal service or the dealer where you purchased the product.

### EN55032 Warning

This is a class A product.

In a domestic environment, this product may cause radio interference, in which case the user may be required to take adequate measures.

### EN55032 Warnung

Warnung! Dies ist eine Einrichtung der Klasse A.

Diese Einrichtung kann im Wohnbereich Funkstörungen verursachen. In diesem Fall kann vom Betreiber verlangt werden, angemessene Maßnahmen durchzuführen.

Das Gerät ist nicht für die Benutzung im unmittelbaren Gesichtsfeld am Bildschirmarbeitsplatz vorgesehen. Um störende Reflexionen am Bildschirmarbeitsplatz zu vermeiden, darf dieses Produkt nicht im unmittelbaren Gesichtsfeld platziert werden.

机器名称: 条码打印机

部件名称	有毒有害物质或元素					
	铅 (Pb)	汞 (Hg)	镉 (Cd)	六价铬 (Cr6+)	多溴联苯 (PBB)	多溴二苯醚 (PBDE)
印刷电路板	×	○	○	○	○	○
电源, 交流转换器 电池	×	○	○	○	○	○
热敏头, 液晶显示屏	×	○	○	○	○	○
电动机, 切纸机	×	○	○	○	○	○
树脂 (ABS, PC等)	○	○	○	○	○	○
金属 (铁, 非铁金属)	×	○	○	○	○	○
电缆等	×	○	○	○	○	○
包装材料 (纸盒等)	○	○	○	○	○	○

本表格依据SJ/T 11364的规定编制。

○：表示该有毒有害物质在该部件所有均质材料中的含量均在GB/T 26572 “电子信息产品中有毒有害物质的限量要求” 的标准规定以下。

×：表示该有毒有害物质至少在该部件的某一均质材料中的含量超出GB/T 26572 “电子信息产品中有毒有害物质的限量要求” 的标准规定。

**环保使用期限**



本标志中的年数，是根据2006年2月28日公布的“电子信息产品污染防治管理办法”和SJ/T11364“产品污染防治标识要求”，适用于在中华人民共和国（除台湾、香港和澳门外）生产或进口的电子信息产品的“环保使用期限”。在遵守使用说明书中记载的有关本产品安全和使用上的注意事项，且没有其他法律和规定的免责事由的情况下，在从生产日开始的上述年限内，产品的有毒，有害物质或元素不会发生外泄或突变，使用该产品不会对环境造成严重污染或对使用者人身，财产造成严重损害。

注1): “环保使用期限”不是安全使用期限。尤其不同于基于电气性能安全，电磁安全等因素而被限定的使用期限。产品在经适当使用后予以废弃时，希望依照有关电子信息产品的回收和再利用的法律与规定进行处理。

注2): 本标志中的年数为“环保使用期限”，不是产品的质量保证期限。对于同一包装内包含电池，充电器等附属品的产品，产品和附属品的环保使用期限可能不同。

## **RoHS Directive**

This product is in conformity with **RoHS Directive 2011/65/EU** on the Restriction of the Use of Certain Hazardous Substances in Electrical and Electronic Equipment.

## **Compliance Status of REACH Regulation**

(1) Status of registered chemical substances

No chemical substances are intentionally emitted, nor are there any chemical substances that are registered with the European Chemicals Agency.

(2) Information about the Substances of Very High Concern (SVHC) contained in the product

Currently, there has been no information communicated regarding SVHC that exceed 0.1% of the product's weight. In the future, if SVHC that exceed 0.1% of the product's weight are found, we will immediately communicate that information.

## **Support and Warranty**

### **Maintenance Support**

SATO provides maintenance support to ensure reliable operation of your product. Access the following site and select your country from the list. Check the information on the displayed page.

<http://www.satoworldwide.com/service-and-support.aspx>

### **Warranty Period for Consumables**

For information on the warranty period for print heads, platen rollers and cutters, refer to the SATO Global Warranty Program.

<http://www.satoworldwide.com/global-warranty-program.aspx>

# 1

## Basic Information

### 1.1 Checking the Bundled Accessories

After unpacking the product, make sure that you have all the bundled accessories. If there are missing items, contact the SATO reseller where you purchased the product.

User documents  
(Quick guide, Safety  
instructions, Global Warranty  
Program leaflet, etc.)

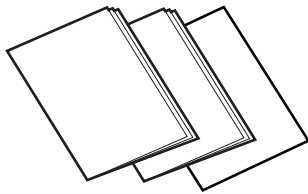

AC power cord\*

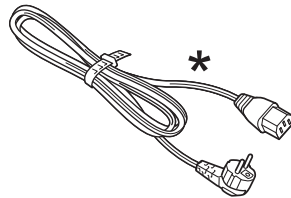

Ribbon core

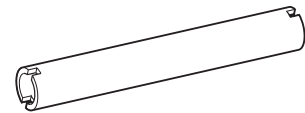

\* The power cord is not supplied depending on the region.  
The shape of power plug varies depending on the region.

#### Note

Keep the packaging box and cushioning material after installing the product. You can pack the product with this packaging box for shipment when requesting for repairs.

### 1.1.1 Installing the Top Cover

The product is packed with the top cover detached. Attach the top cover to the product's main body before using it.

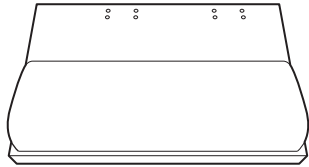

Outer view of top cover

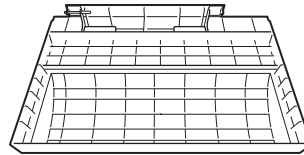

Inner view of top cover

- 1** Align and match the shape of the top cover's bracket hole with the pin on the product side.

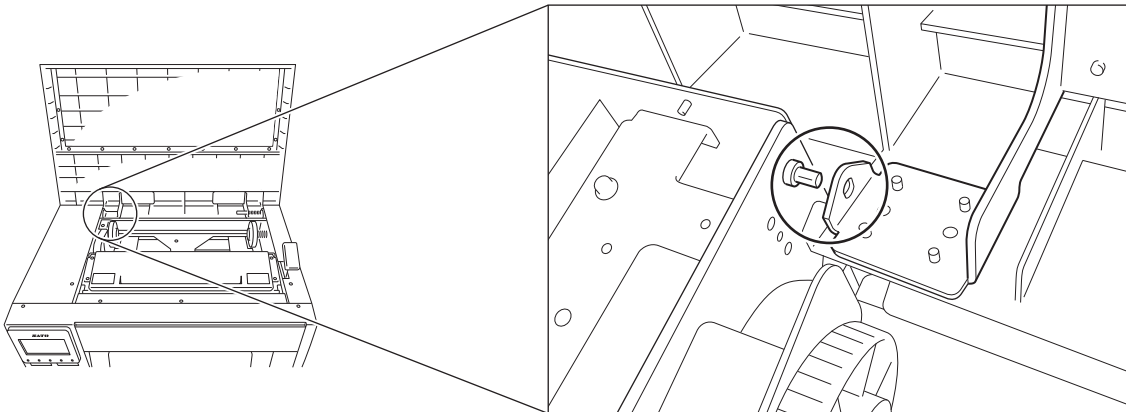

- 2** Pull the pin on the top cover side to the left and align the tip of the pin with the hole of this product.

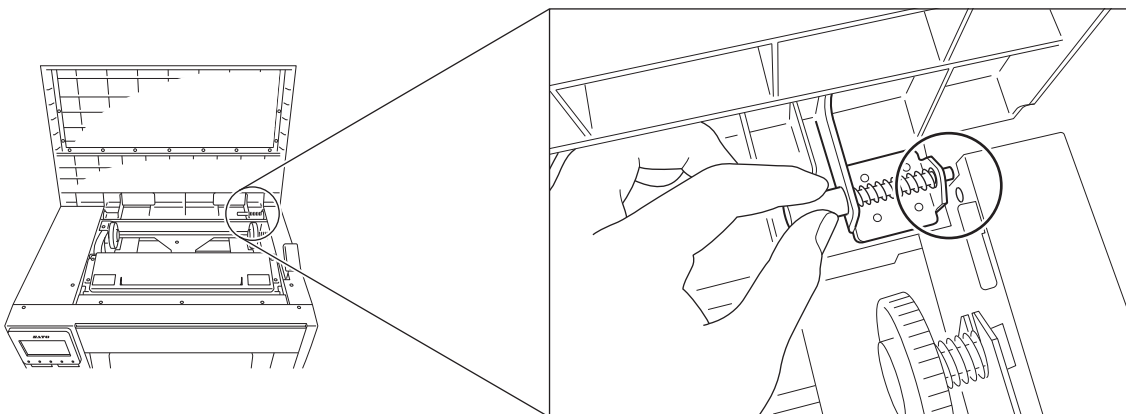

- 3** Release the pin and make sure that the pin of the top cover has entered the hole of this product.



---

## 1.2 Optional Devices

The optional devices for the product are as follows. The optional devices can be factory installed or installed by the customer engineer. Contact your SATO reseller or technical support center.

Optional Devices	Description
Stacker (STG112)	Allows stacking of cut media for continuous high volume printing.
Unwinder (UWG112)	Allows a large media roll of up to 10.5" wide to be run through the product.
Real-time clock (Calendar) kit	A calendar system for printing the date and time on a label to output.

---

### Note

For more details about the optional devices, contact your SATO reseller.

---

## 1.3 Parts Identification of the Product

### 1.3.1 Front View

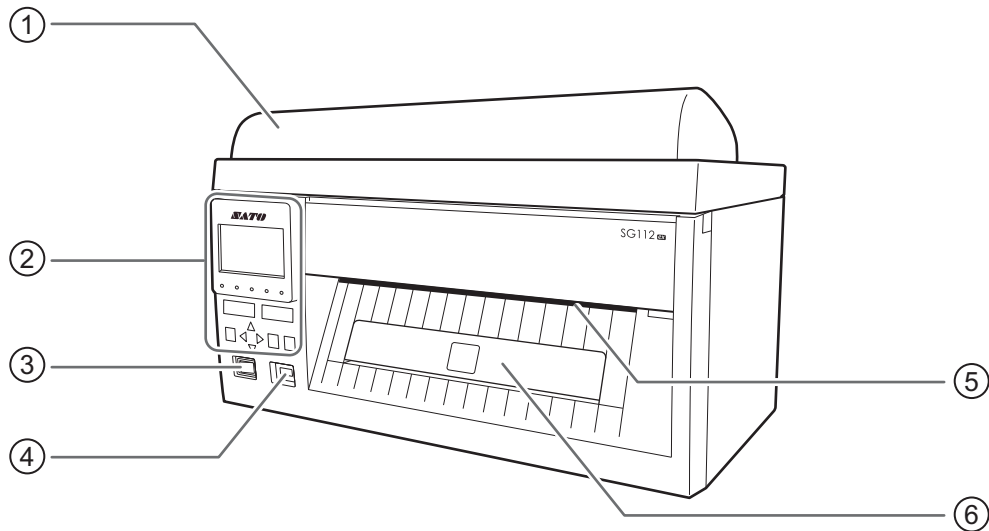

**① Top cover**

**② Operator panel**

Refer to [Section 1.4.1 Operator Panel](#) for details.

**③ Power (I/O) switch**

Press this switch to turn on (I) or turn off (O) the power.

**④ USB connector (Type A)**

Enable the storage of product settings information with USB memory.

**⑤ Media discharge outlet**

**⑥ Media tray**

Holds the cut media after feed out from the media discharge outlet.

**⚠ CAUTION**

Be sure to perform a virus check on the USB memory before connecting it to the product. SATO Corporation shall not be held responsible for any product malfunctions caused by a virus spread via USB memory.

## 1.3.2 Rear View

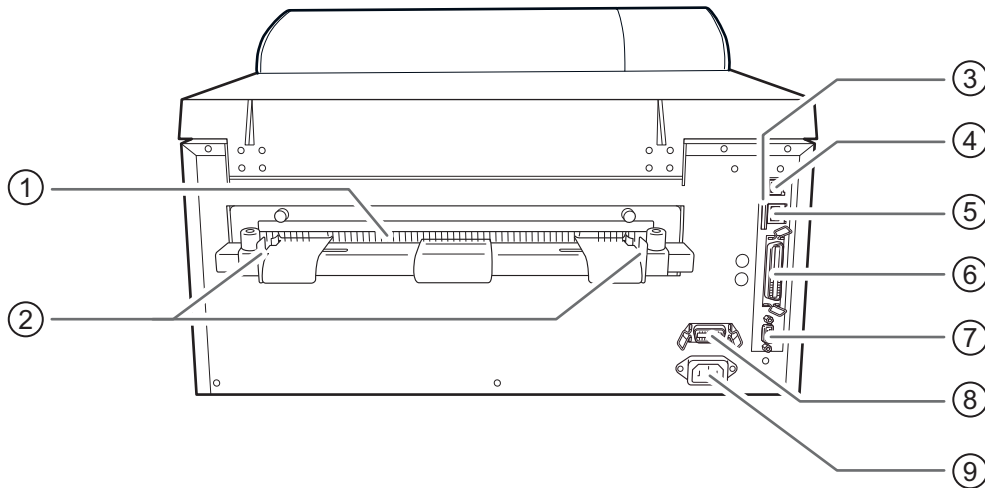

### ① Media inlet

Feed the media in this inlet.

### ② Media guide

Adjust the media guide to the width of the media.

### ③ SD CARD slot

To install an SD card for additional memory.

### CAUTION

Be sure to perform a virus check on the SD card before connecting it to the product. SATO Corporation shall not be held responsible for any product malfunctions caused by a virus spread via SD card.

### ④ USB connector (Type B)

To connect the product to the computer using the USB interface.

### ⑤ LAN connector

To connect the product to the computer using the LAN interface.

### ⑥ IEEE1284 connector

To connect the product to the computer using the IEEE1284 interface.

### ⑦ RS-232C connector

To connect the product to the computer using the RS-232C serial interface.

### ⑧ EXT connector (External signal interface)

Interface connector for external signals. Connect the optional device to this terminal.

### ⑨ AC input terminal

Supplies power to the product through the inserted power cord.

Before connecting, make sure that the AC voltage of your region is in the range of AC 100 to 240 V, 50 to 60 Hz.

### 1.3.3 Internal View

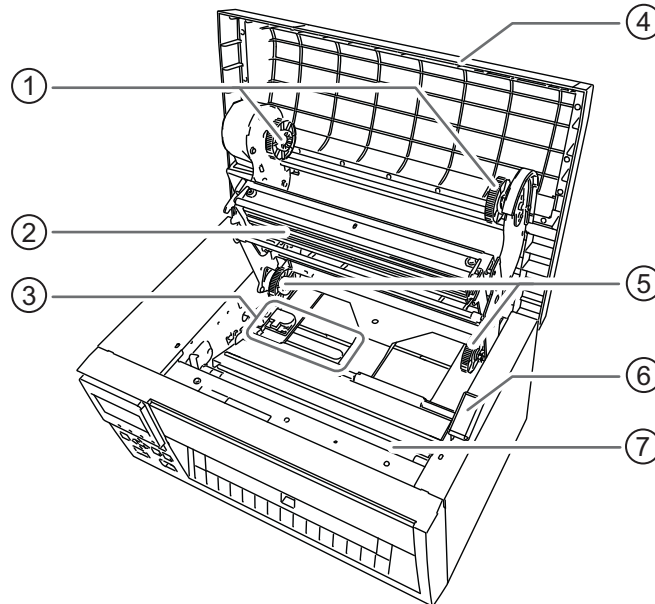

---

① **Ribbon rewind holder**

Used to hold the ribbon core for winding up the used ribbon.

② **Print head (Consumables)**

Creates an image directly on the media or by using a ribbon. Clean the print head regularly.

③ **Media sensor assembly**

This is where the media sensors are located. Adjust the media guide to adjust the position of the media sensors.

④ **Top cover**

⑤ **Ribbon supply holder**

Used to hold the ribbon.

⑥ **Head release lever**

Used to release the print head assembly.

⑦ **Platen roller (Consumables)**

## 1.4 Parts on the Operator Panel

### 1.4.1 Operator Panel

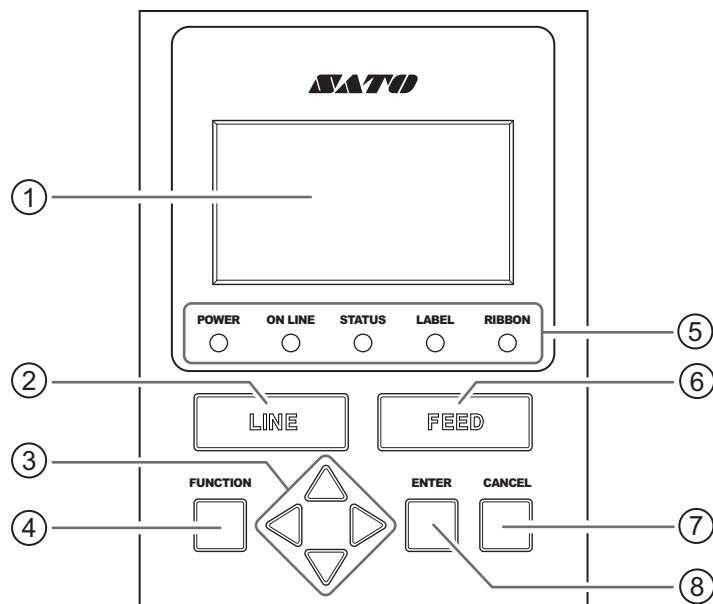

#### ① LCD

#### ② LINE button

Toggle between online and offline modes.

#### ③ ◀/▶/▲/▼ Arrow buttons

Navigate the selection or set numbers in the screen menu.

Press the ▲ button to adjust the buzzer volume when the product is in online or offline mode.

Press the ▼ button to enter the adjustment mode when the product is in offline mode.

#### ④ FUNCTION button

Operates the set function when the product is in normal mode.

Returns to the setting mode menu from the setting screens.

#### ⑤ LED indicators

Refer to [Section 1.4.2 LED Indicators](#) for details.

#### ⑥ FEED button

Feed a piece of media and align the media to the proper position when the product is in offline mode.

#### ⑦ CANCEL button

Go to the CANCEL PRINT JOB screen when the product is in offline mode.

Returns to the previous setting screen when the product is in setting mode.

#### ⑧ ENTER button

Enter the setting mode menu when the product is in offline mode.

Confirm the selected item or setting value when the product is in setting mode.

## 1.4.2 LED Indicators

LED Indicator	Color	Description
POWER	Green	Lights up in green when the power is on.
ON LINE	Green	Lights up when product is ready to receive data or is in online mode. Light is off when the product is in offline or error mode.
STATUS	Green/ Red	Flashes in green when Receive buffer is near full. Lights up or flashes in red when detecting an error. Light is off during data communication and not detecting any error.
LABEL	Red	Lights up in red when detecting paper end. Light is off when not detecting paper end.
RIBBON	Red	Flashes in red when detecting ribbon near end. Lights up in red when detecting ribbon end. Light is off when not detecting ribbon near end and ribbon end.

# 2

## Installing the Product

---

### 2.1 Installation Precautions

Install the product in a location as follows:

- A location that is horizontal and stable.
- A location that has sufficient space for operating the product.

Do not install the product in a location as follows. Doing so could cause the product to malfunction.

- A location that is subject to vibration.
- A location with high temperature and humidity.
- A dusty location.
- A location exposed to direct sunlight.
- A location with a lot of electrical noise.
- A location with a large fluctuation in power.
- A location with an explosive atmosphere (flammable gas or vapor).

## 2.2 Installation Space

Make sure that there is sufficient space around the product so that the top cover can be fully opened when operating or cleaning the product, or replacing consumables. And make sure that there is sufficient space on the rear side of the product so that the media or the optional unwinder can be installed. The illustrations in this section show the product from different angles, providing dimensions and spatial requirements.

### 2.2.1 Front View

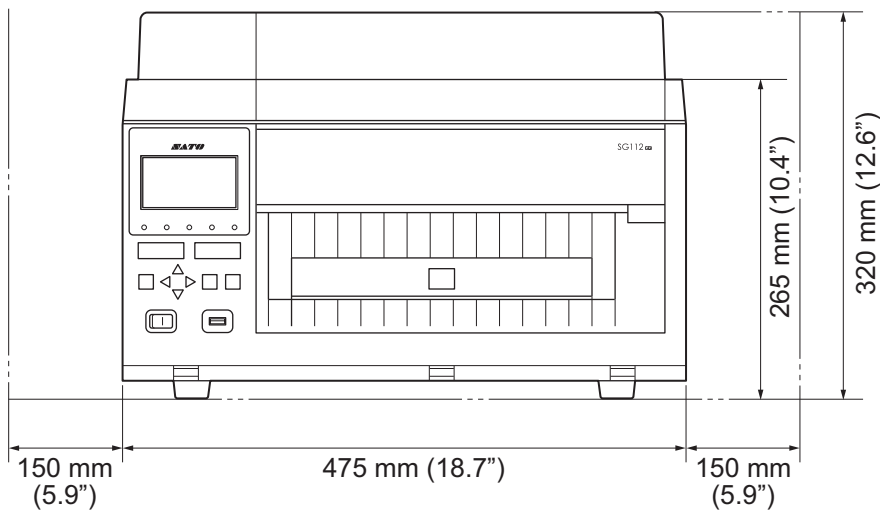



## 2.2.2 Side View

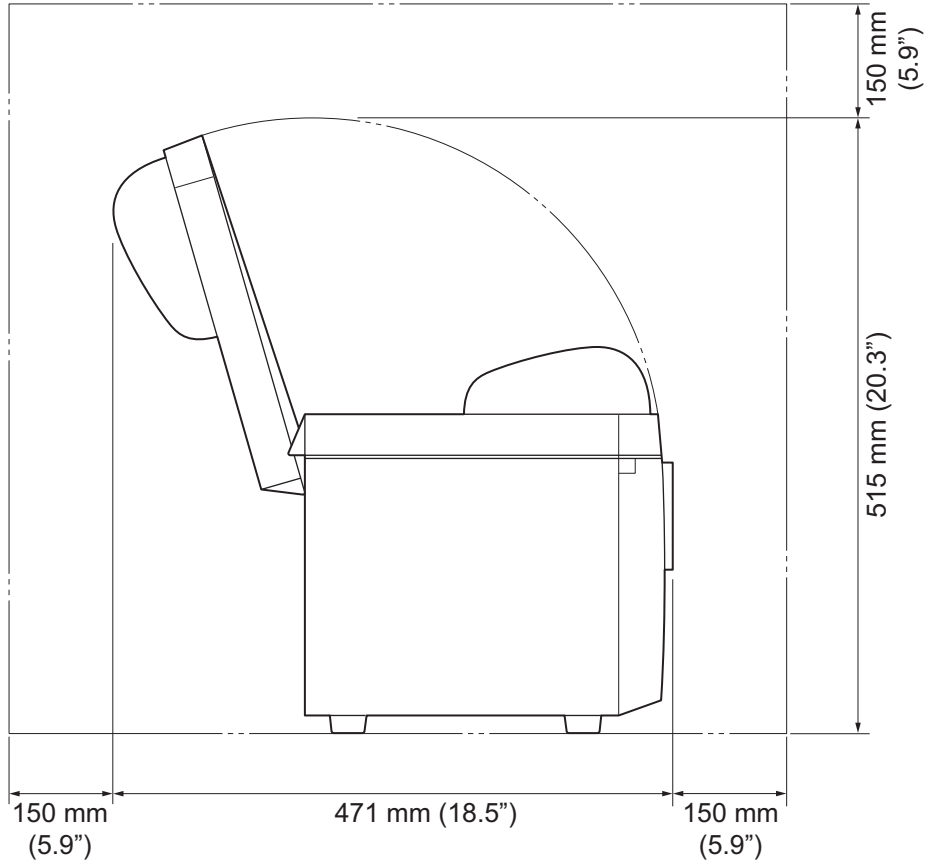

## 2.3 Connecting the Product

This section explains how to connect the product to a computer or other devices.

### 2.3.1 Connecting the Product to a Computer

The product supports various interfaces and can be connected to a computer in an optimum way for your environment. When you have installed the printer driver to the computer, the data created with the computer (documents and illustrations) can be printed to a label through easy operations. Also, you can print by sending a command directly to the product through our All-In-One-Tool application.

For more information about the printer driver and All-In-One Tool, please refer to the respective manual in our SATO worldwide website ([www.satoworldwide.com](http://www.satoworldwide.com)).

The product can be connected to a computer in the following ways.

#### 1 Connect the Interface.

Refer to [Section 2.3.2 Available Interfaces](#) for available interfaces and the references for each interface connection.

#### 2 Configure the interface settings.

Refer to [Section 2.3.7 Interface Settings](#) for more details on interface settings.

- When you connect them with LAN interfaces, configure the communication conditions, such as the IP address of the product.
- When you connect them with other interfaces, configure the communication conditions when needed to adapt to the computer to which you are connecting.
- To use the printer driver, the communication protocol must be set to Status4. (The initial value for the communication protocol for the product's interfaces is Status4.)

#### 3 Install the Printer Driver.

You may download the printer driver and installation manual from our SATO worldwide website ([www.satoworldwide.com](http://www.satoworldwide.com)).

## 2.3.2 Available Interfaces

This product supports the following interfaces.

### 1) USB

Refer to [Section 2.3.3 USB Interface Connection](#) for details on connecting the USB interface.

### 2) LAN

Refer to [Section 2.3.4 LAN Interface Connection](#) for details on connecting the LAN interface.

### 3) IEEE1284

Refer to [Section 2.3.5 IEEE 1284 Interface Connection](#) for details on connecting the IEEE 1284 interface.

### 4) RS-232C

Refer to [Section 2.3.6 RS-232C Interface Connection](#) for details on connecting the RS-232C interface.

### 5) External signal (EXT)

Refer to [Section 2.3.9 EXT External Signal Interface Connection](#) for details on connecting the external signal interface.

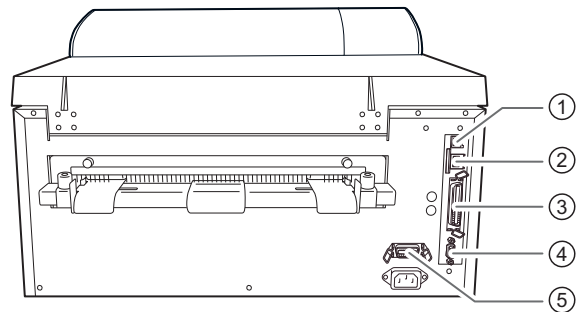

## Note

- A product connected with multiple interface cables can continue to operate when receiving data. However, you cannot receive data from more than one interface at a time. Normally, do not use multiple interfaces at a time.
- The product prints the received data in order of reception. The next received data is stored in the receive buffer while the first data is printed.

## CAUTION

Do not connect or disconnect the interface cables (or use a switch box) while power is supplied to either the product or computer. This may cause damage to the interface circuitry in the product or computer and is not covered by warranty.

### 2.3.3 USB Interface Connection

**1** Make sure that the product is powered off.

**2** Connect the USB cable to the USB connector (Type B) of the product.

- Use a cable that is compatible with the standard of the interface board as stated in [Section 8.9.1 USB Interface](#). Check the orientation of the connector before you make the connection.
- The USB interface is selected after connecting the USB cable to the computer and the product, and powering on the product while the computer is turned on.

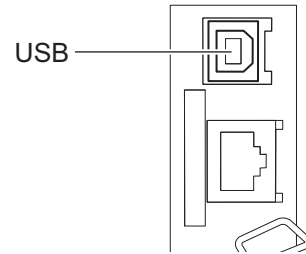

**3** Configure the interface settings.

Refer to [Section 2.3.7 Interface Settings](#) for more details on interface settings.

---

#### Note

- If the product is powered on without installing the printer driver, Windows' Plug & Play runs. When using the printer driver, do not power on the product while the USB cable is connected, until instructed in the procedure for installing the printer driver.
  - The recommended USB cable is the one within 2 meters (6.6 feet) length.
- 

### 2.3.4 LAN Interface Connection

**1** Make sure that the product is powered off.

**2** Connect the LAN cable to the LAN connector of the product.

- Use a cable that is compatible with the standard of the interface board as stated in [Section 8.9.2 LAN Interface](#). Check the orientation of the connector before you make the connection.

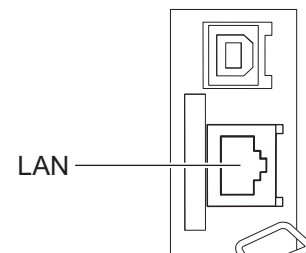

**3** Configure the interface settings.

Refer to [Section 2.3.7 Interface Settings](#) for more details on interface settings.

---

#### Note

- The communication condition settings must be configured according to your network environment. Set the IP address of the product.
  - To use the printer driver, the communication protocol must be set to Status4. (The initial value for the communication protocol for the product's LAN interface is Status4 ENQ.)
-

### 2.3.5 IEEE 1284 Interface Connection

- 1 Make sure that the product is powered off.
- 2 Connect the IEEE1284-compliant cable to the IEEE1284 connector of the product.
  - Use a cable that is compatible with the standard of the interface board as stated in [Section 8.9.4 IEEE1284 Interface](#). Check the orientation of the connector before you make the connection.
- 3 Configure the interface settings.
 

Refer to [Section 2.3.7 Interface Settings](#) for more details on interface settings.

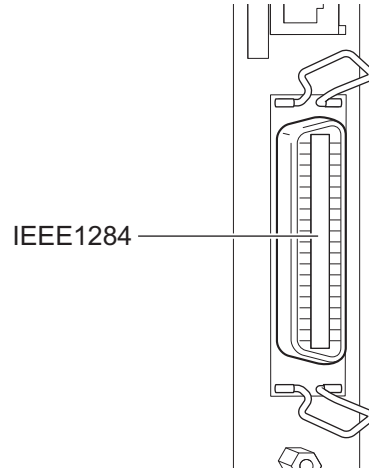

#### Note

- If the product is powered on without installing the printer driver, Windows' Plug & Play runs. When using the printer driver, do not power on the product while the cable is connected, until instructed in the procedure for installing the printer driver.
- IEEE1284-compliant: compatible mode, ECP mode, and nibble mode are supported.
- Some computers may not support ECP mode.
- ECP mode is configured in the BIOS settings of the computer. Some computers may use the software tools for Windows.
- Some computer models may not perform ECP operations even if they are set to ECP mode. Contact the computer manufacturer.
- Printing using the USB parallel conversion cable is not guaranteed. Also, no support for the connection procedure is provided.

### 2.3.6 RS-232C Interface Connection

- 1 Make sure that the product is powered off.
- 2 Connect the RS-232C cable to the RS-232C connector of the product.
  - Use a cable that is compatible with the standard of the interface board as stated in [Section 8.9.3 RS-232C Interface](#). Check the orientation of the connector before you make the connection.
- 3 Configure the interface settings.
 

Refer to [Section 2.3.7 Interface Settings](#) for more details on interface settings.

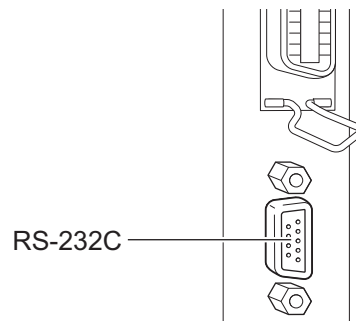

**Note**

- The interface settings of the computer can be confirmed by the following. In the Device Manager, right-click [Ports] > [Communications Port (COM1)] and select [Properties]. Then, check the [Port Settings] tab of the displayed Properties screen.
  - For the RS-232C cable, note that the connection cable varies according to the communication protocol setting. If you use the wrong cable, it will not operate correctly.
  - If the communication settings differ between the computer and product, it will not operate correctly. A communication error will be detected.
  - To use the printer driver, the communication protocol must be set to Status4. (The initial value for the communication protocol for the product's RS-232C interface is STATUS4.)
  - Printing using the USB serial conversion cable is not guaranteed. Also, no support for the connection procedure is provided.
- 

**2.3.7 Interface Settings**

You can set the various interface settings of the product through the interface mode menu. For details, refer to [Section 4.2.6 Interface Mode](#).

In interface mode, you need to configure both the data port and sub port. An overview of each port is shown below.

**Data port**

When the interface is set to the data port, it can receive various SBPL commands and receive print data from the host computer.

Data port selection: USB, LAN, IEEE1284, RS-232C

\* You cannot select the interface that has already been set for the SUB PORT.

**Sub port**

This port is for monitoring the printer status.

Sub port selection: NONE, USB, LAN, RS-232C, IEEE1284

\* You cannot select the interface that has already been set for the DATA PORT.

---

**Note**

The main port and sub port cannot simultaneously use the same interface.

---

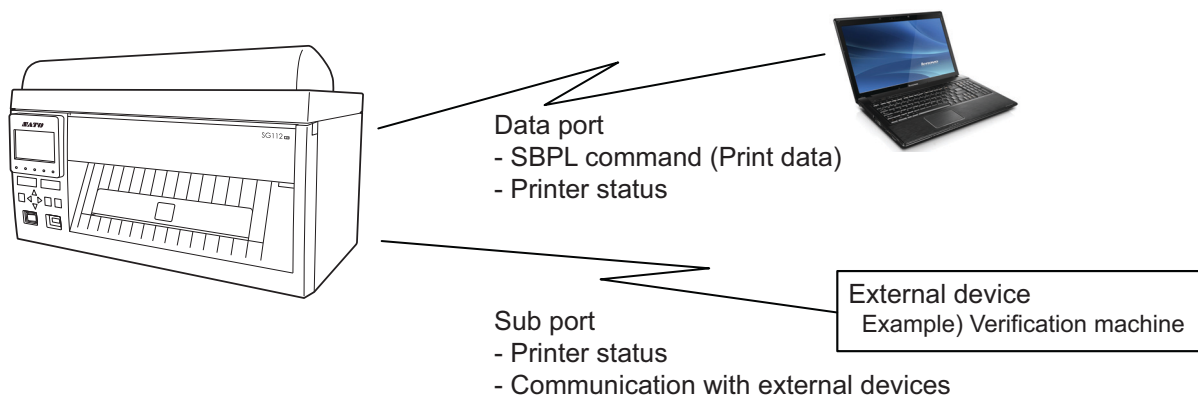

### 2.3.8 Interface Combination

The interface combinations that can be used for the data port and sub port are as follows.

		Data Port			
		USB	LAN	RS-232C	IEEE1284
Sub Port	USB	x	o	o	o
	LAN	o	x	o	o
	RS-232C	o	o	x	o
	IEEE1284	o	o	o	x
	NONE	o	o	o	o

[o: configurable, x: not configurable]

#### Note

- Do not select the same interface for the data port and sub port.
- The sub port cannot be used if you have set ENABLE in the INTERFACE AUTO SELECT screen.

### 2.3.9 EXT External Signal Interface Connection

You can connect the product with other peripherals through EXT connector. With the control signal, you can control print operations; such as monitoring the condition of the product, starting printing, and reprinting.

**1** Make sure that the product is powered off.

**2** Connect the EXT cable to the EXT connector of the product.

- Use a cable that is compatible with the standard of the interface board as stated in [Section 8.9.5 External Signal Interface \(EXT\)](#). Check the orientation of the connector before you make the connection.

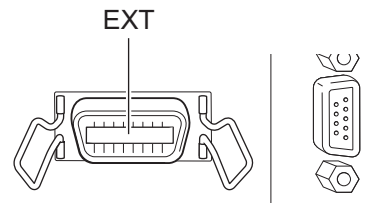

**3** Configure the external signal settings.

- In **ADVANCED MODE**, set the **EXTERNAL SIGNAL** to **ENABLE**.
  - Set the **EXTERNAL SIGNAL TYPE** and **EXTERNAL REPRINT** according to your application.
- Refer to [Section 4.2.8 Advanced Mode](#) for the sequence of the setting screens and [Section 8.9.5 External Signal Interface \(EXT\)](#) for more details.

## 2.4 Connecting the Power Cord

---

### **WARNING**

- Do not power on or off the product, connect or disconnect the power cord while your hands are wet. Doing so could cause an electric shock.
  - Always connect the ground wire to a ground terminal. Electric shock could occur if you do not.
  - Make sure that the AC voltage of your region is in the range of AC 100 - 240 V, 50 - 60 Hz. If your local voltage is not in the stated range, contact your SATO reseller or technical support center.
- 

### **CAUTION**

The attached power cord is designed exclusively for this product. Do not use it with other devices.

---

### **1** Connect the power cord to the **AC input terminal** ① at the rear of the product.

Take note of the orientation of the connector.  
Secure the product with one hand, and insert the connector tightly.

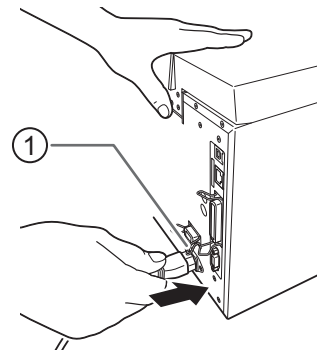

### **2** Insert the power plug into an AC outlet.

\*The shape of power plug varies depending on the region.

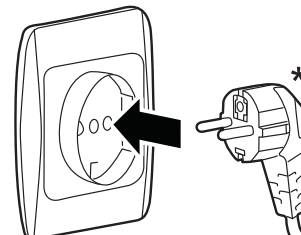

---

### **Note**

This product is also designed for IT power distribution system with phase-to-phase voltage 230 V.

---



## 2.5 Power On/Off the Product

### WARNING

Do not power on or off the product, connect or disconnect the power cord while your hands are wet. Doing so could cause an electric shock.

### CAUTION

- Do not power off the product during operation, such as when printing or updating. Doing so could cause a malfunction of the product.
- Do not disconnect the power cord until the powering off process is completed on the product.
- An incorrect power on/off operation may damage the product settings. In such a case, the product settings are reset to their default values. It is always recommended to ensure changes made to menu settings are saved appropriately and allow the product to set to offline mode.

### 2.5.1 Power On the Product

- 1 Press the power switch on the operator panel to "I" position.

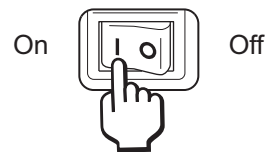

- 2 **ONLINE** shows on the screen and the POWER indicator lights up in green.

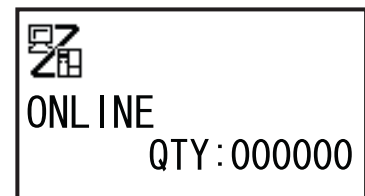

## 2.5.2 Power Off the Product

- 1 Make sure that the product is in offline mode before you power off.  
If **ONLINE** shows on the screen, press the **LINE** button to change to offline mode.

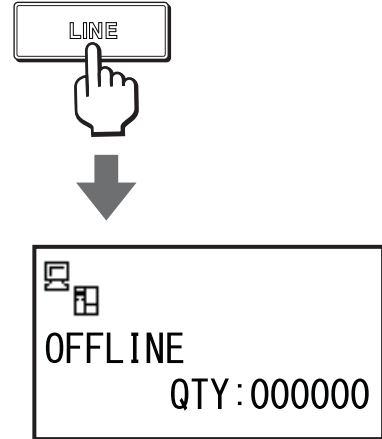

- 2 Press the power switch on the operator panel to "O" position.  
The **POWER** indicator lights off.

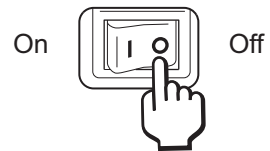

## 2.6 Installing Optional Memory Storage

The optional SD card or USB memory can be used for uploading and downloading data (print format, graphics, extended characters) registered in the product and printer firmware. It is not an interface for communication.

Contact your SATO reseller or service center for the recommended SD card or USB memory.

### CAUTION

Be sure to perform a virus check on the USB memory or SD card before connecting it to the product. SATO Corporation shall not be held responsible for any product malfunctions caused by a virus spread via the USB memory or SD card.

### 2.6.1 Installing the Optional SD Card

You can install an optional SD card into the SD card slot located on the rear of the product. When using the SD card for the first time, format the SD card in the Memory mode. Refer to [Section 4.2.7 Memory Mode](#) for details.

- 1 Power off the product.
- 2 Insert the optional SD card into the **SD CARD** slot with the orientation the same as shown in the picture.

#### Note

- Use only SATO recommended SD card. Contact your SATO reseller for details.
- SD card: Maximum 2 GB
- SDHC card: Minimum 4 GB - Maximum 32 GB

- 3 To seat the SD card in the **SD CARD** slot, push it in until it makes a slight clicking sound and is almost completely inside the product.

When seated and ready to operate, only a very small portion protrudes, approximately 3.18 mm (0.125").

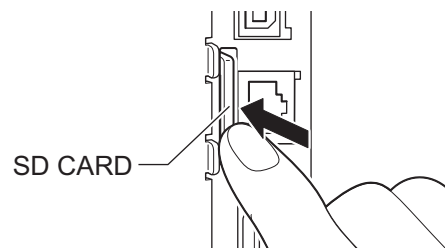
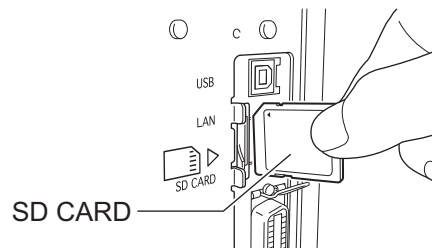

### 2.6.2 Removing the Optional SD Card

- 1** Power off the product.
- 2** Press the card edge slightly to release the SD card from the SD CARD slot.  
The SD CARD slot will immediately release the SD card.

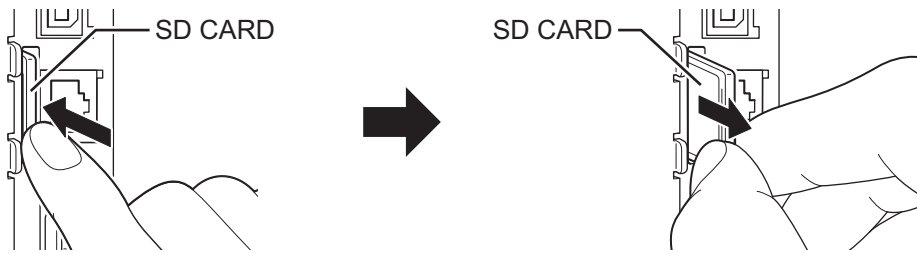

---

**⚠ CAUTION**

Do not remove the SD card while the product is accessing the data in the SD card. Doing so may result in data corruption.

---

### 2.6.3 Installing the Optional USB Memory

When using the USB memory for the first time, format the USB memory in the Memory mode. Refer to [Section 4.2.7 Memory Mode](#) for details.

- 1 Power off the product.
- 2 Insert the optional USB memory into the  **USB connector** (Type A) on the front of the product.

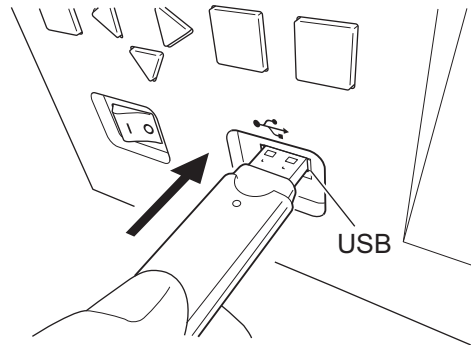

#### Note

- USB flash memory: Maximum 32 GB.
- The product does not support USB memory with security functions such as fingerprint authentications.
- The product does not support connection through the USB hub.

#### To remove the USB memory from the product

Power off the product before removing the USB memory.

#### CAUTION

Do not remove the USB memory while the product is accessing the data in the USB memory. Doing so may result in data corruption.

**This page is intentionally left blank.**

# 3

## Loading the Ribbon and Media

This product supports two types of print methods, namely thermal transfer and direct thermal. Thermal transfer is a print method that transfers the ink of the ribbon to the media. Direct thermal is a print method that creates the image on direct thermal media. Ribbon is not necessary if you are using direct thermal media.

### 3.1 Checking the Ink Side of the Ribbon

This product only supports ribbon with Face-in winding direction. Face-in means the ink is on the inner side. You can examine the ink side of the ribbon using the following procedure.

#### Note

This checking method is for reference only. It is only applicable to certain types of ribbon.

- 1 Place the outer side of the ribbon onto the media (touching).
- 2 Scratch the inner side of the ribbon with your fingernail or a pointed object.
- 3 If there is a mark on the media, the ink is coated on the outer side of the ribbon.

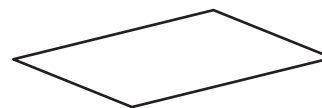
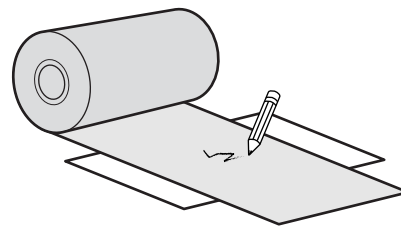

The ink is coated on the inner side. (Face-in ribbon)



The ink is coated on the outer side. (Face-out ribbon)

## 3.2 Loading the Ribbon

Use merchandise from our specified suppliers on the product, for optimum print quality.

### CAUTION

- The print head and its surroundings are hot after printing. Be careful not to touch it, to avoid being burned.
- Touching the edge of the print head with your bare hand could cause injury.

The routing path of the ribbon is shown in the right picture.

 Face-in ribbon  
 Media

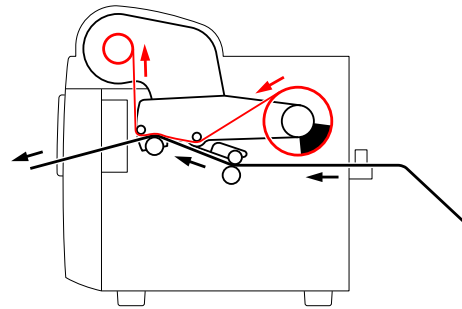

### Note

You can also refer to the routing path sticker located on the top left corner of the product after the top cover is opened.

## 1 Open the top cover ①.

### CAUTION

Open the top cover fully to prevent accidental drop of the cover.

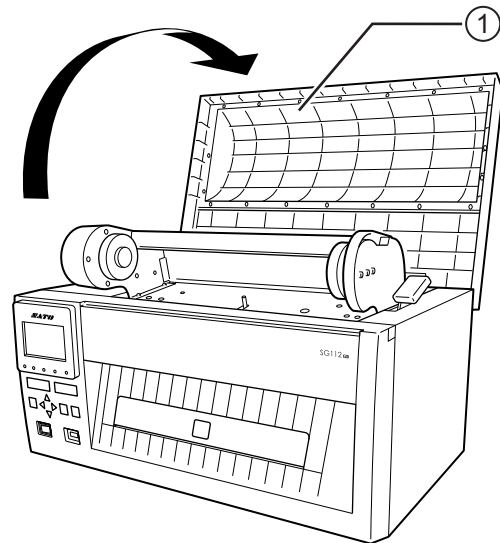



- 2** Pull the **head release lever** ② forward to unlock the print head.

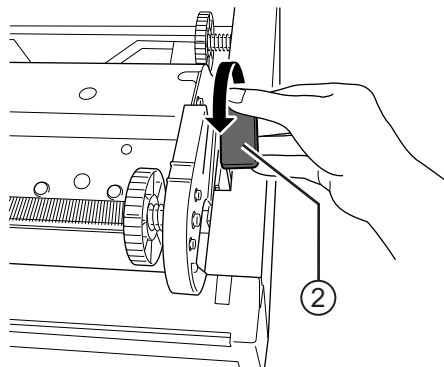

- 3** Lift up the **print head assembly** ③ to the maximum.

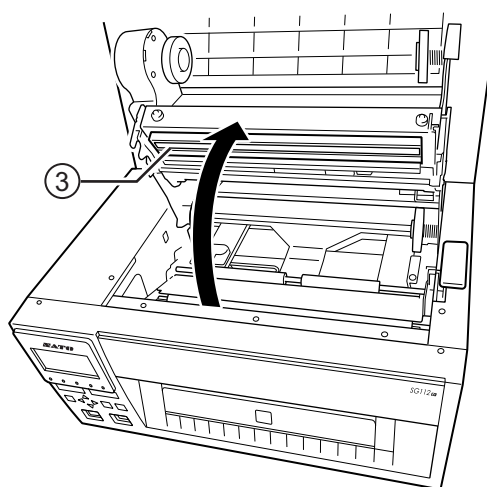

- 4** Align the **ribbon** ④ with the **ribbon supply holder** ⑤ on the right side of the product, and then insert the core onto the ribbon supply holder.

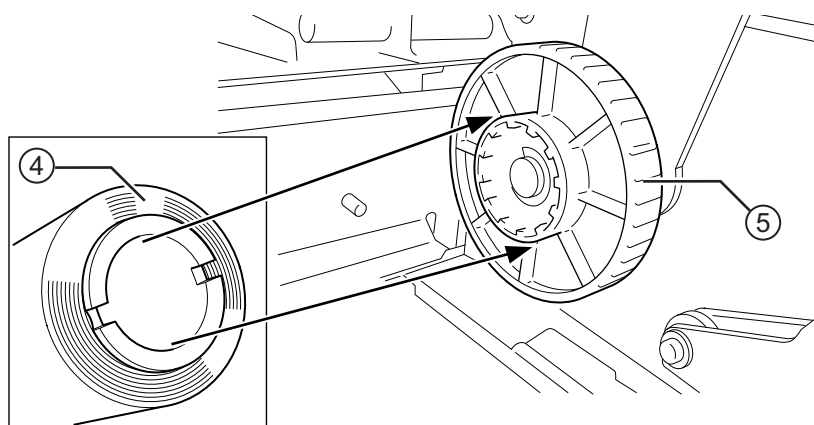

#### Note

- Make sure the wind direction of the ribbon roll is according to the routing path sticker pasted on the product.
- Make sure that the ink side of the ribbon is facing down when passing it below the print head.

- 5** While pressing the ribbon set on the right, align the concave part of the **ribbon** with the convex part of the left **ribbon supply holder** and set.

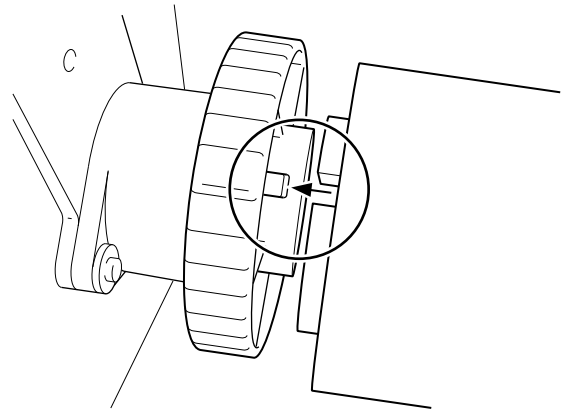

- 6** Align the recess of an **empty ribbon core** ⑥ to the convex part of the right **ribbon rewind holder** ⑦, and then insert the core onto the ribbon rewind holder.

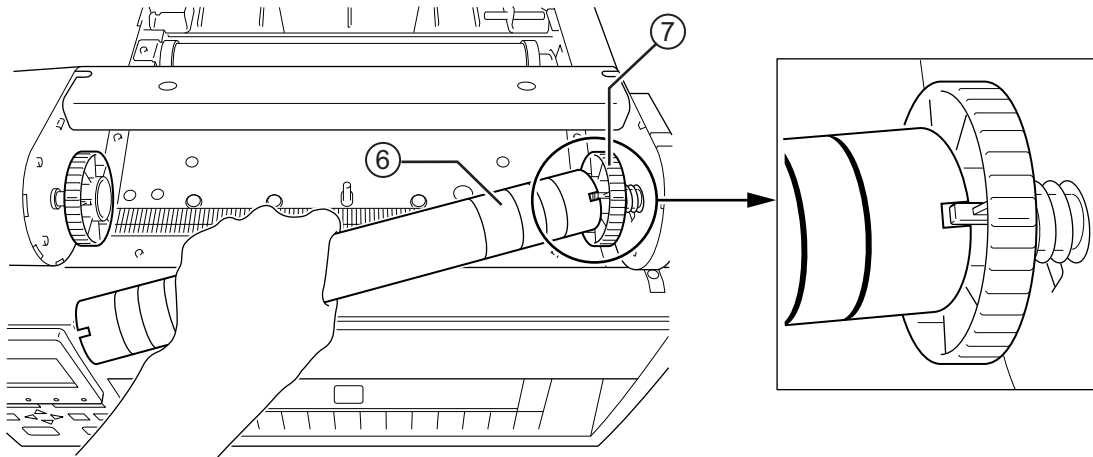

- 7** While pressing the empty ribbon core set on the right, align the concave part of the **ribbon core** with the convex part of the left **ribbon rewind holder** and set.

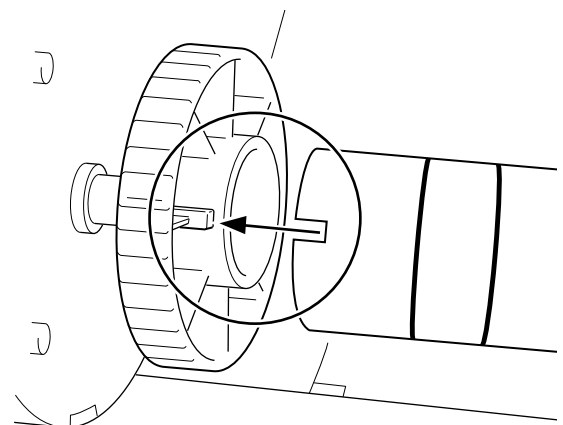

- 8** From the **ribbon supply holder**, thread the ribbon under the **print head** and through the **ribbon rewind holder**.

Refer to the routing path sticker pasted on the product.

- 9** Wind the ribbon around the **empty ribbon core** ⑥ on the **ribbon rewind holder**. Attach the free end of the ribbon to the ribbon core with adhesive tape ⑧.

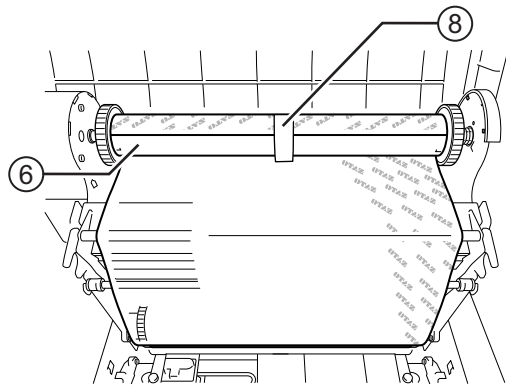

- 10** Turn the **ribbon rewind holder** in the direction of the arrow for several rounds, to wind the ribbon.

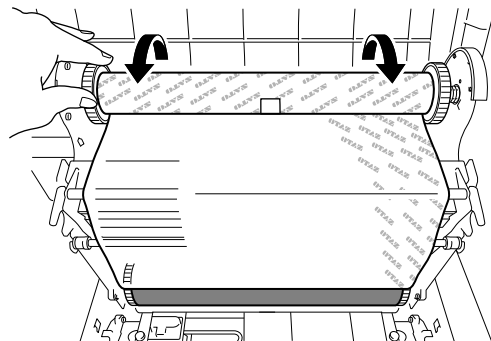

- 11** Close the **print head assembly** ③. Press on both sides as shown by the arrow to close it tightly until it clicks.

- 12** Close the **top cover**.

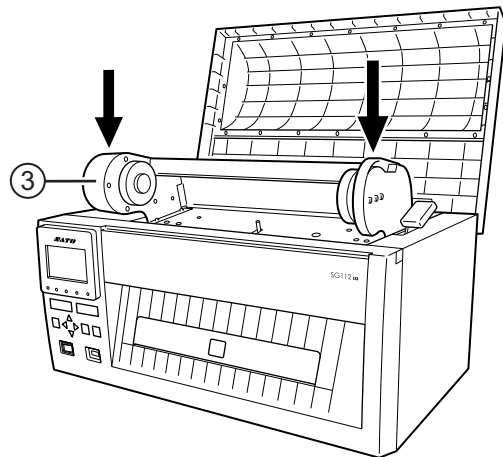

**CAUTION**

When closing the top cover, be careful not to pinch your fingers.

### 3.3 Usable Media

This product can print on two types of media; media roll with an optional unwinder and fan-fold media. The product uses media sensors to detect I-marks or Gaps on the media in order to precisely print the content.

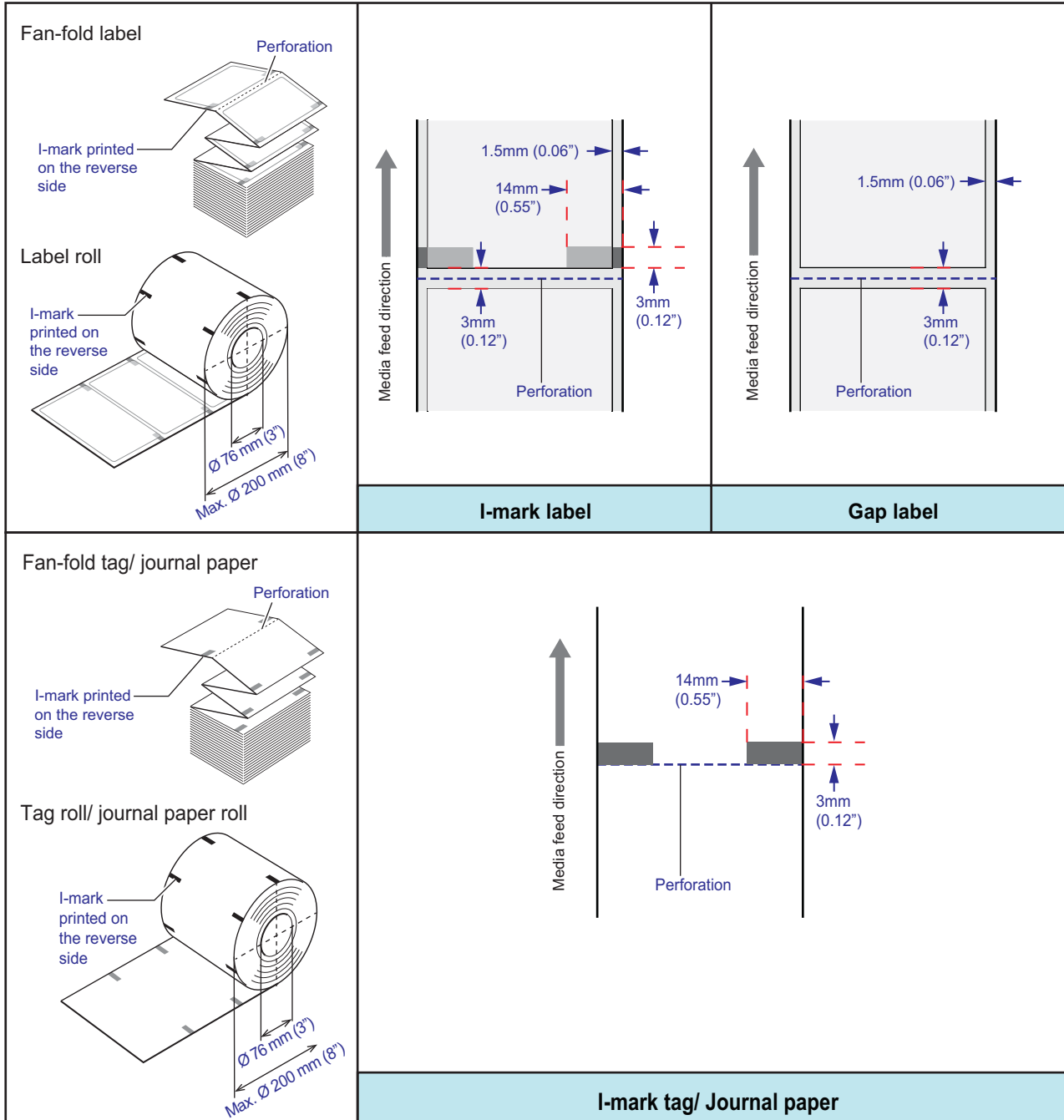

## 3.4 Loading Media

Use consumables from our specified suppliers on the product, for optimum print quality.

### CAUTION

- The print head and its surroundings are hot after printing. Be careful not to touch it, to avoid being burned.
- Touching the edge of the print head with your bare hand could cause injury.

### Note

The usable media sizes, the output speed and print quality vary depending on the media specification, media and ribbon combination, product settings and outputting environment. It is recommended to perform a test print with the media and ribbon to be used in advance.

### 3.4.1 Loading Fan-fold Media

- 1** Loosen the **media guide thumb screws** ① on the back of the product.
- 2** Adjust the **media guide** ② of both sides with both hands to fit the width of the media.
- 3** Press the power switch on the operator panel to "I" position.

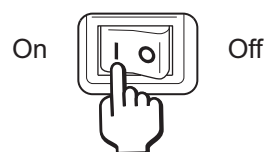
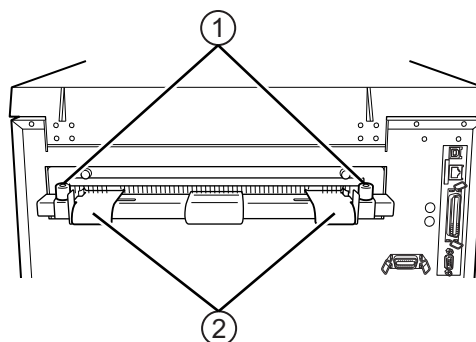

### Note

If Paper end error occurred, open the top cover and the print head assembly. Make sure that there is no media left in the media path. Then close the print head assembly and the top cover.

The display on the operator panel changes to offline mode.

### CAUTION

When closing the top cover or the print head assembly, be careful not to pinch your fingers.

**4** Feed the media (print side face up) with both hands into the **media inlet** ③ located at the back of the product.

When media is inserted, it feeds media with automatic paper feed function.

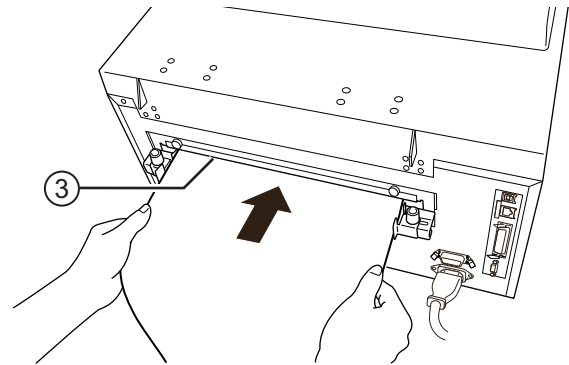

**Note**

- Place the media so that the media is straight as shown in the picture.
- Make sure that there is no obstruction on the rear of the product, providing a smooth flow of the media.
- The automatic paper feed function corresponds to media with thickness of 0.12 mm (0.005") or more. When using media less than 0.12 mm (0.005"), load the media manually. Open the top cover and unlock the print head assembly, insert the media from the media inlet, then pass the media between the print head and the platen roller, and close the print head assembly.
- The maximum stacking height of the fan-fold media is 100 mm (3.9") from the surface on which the product rests.

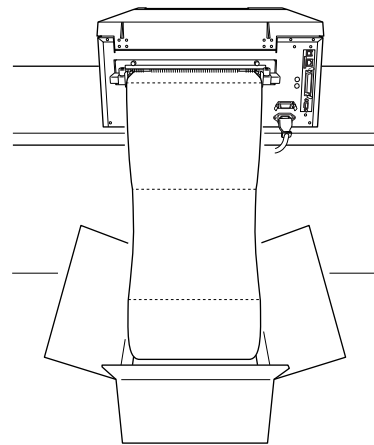

**CAUTION**

When closing the top cover or the print head assembly, be careful not to pinch your fingers.

**5** After completing the media feed, press the **LINE** button to bring it online.

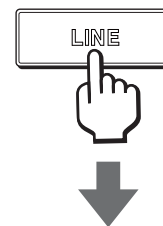

**6** After loading the media and ribbon, perform a test print to make sure that the media is loaded correctly.

Refer to the [Section 4.2.11 Test Print Mode](#) for details on how to perform a test print.

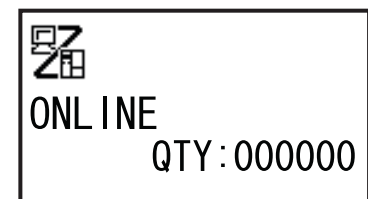

### 3.4.2 Loading Media Roll

When using media roll, an optional **UWG112 unwinder** ① is required. Contact your SATO reseller for more details.

**Note**

Refer to the installation manual of the optional UWG112 unwinder for more details.

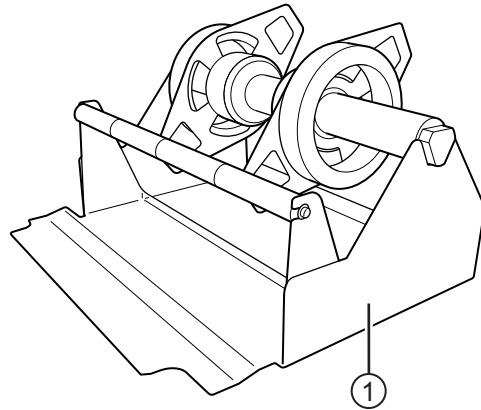

- 1 Install the optional unwinder to the back of the product.

Insert the end of the **media feeder tray** ② so that it is in between the product's rubber feet.

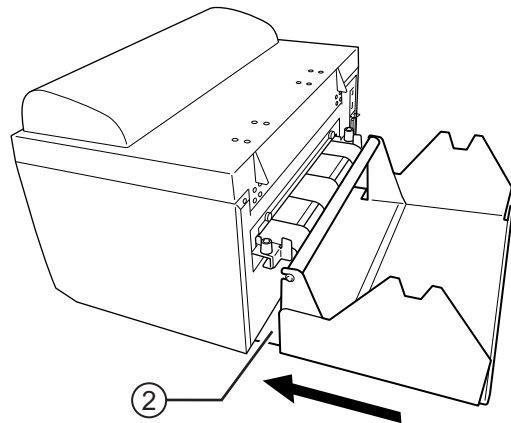

- 2 Loosen the **securing screw** ③ on one side of the **media feeder spindle** ④, align the scale with the media width, and tighten the securing screw ③.

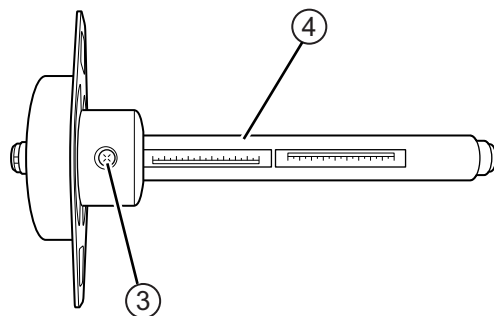

- 3** Set the media roll onto the **media feeder spindle** and insert the other **roll guide** ⑤.

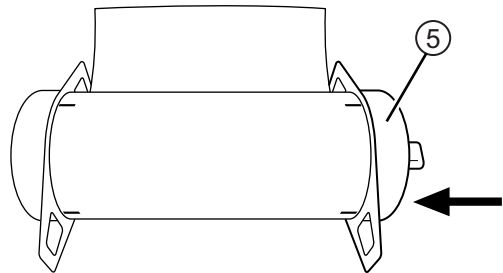
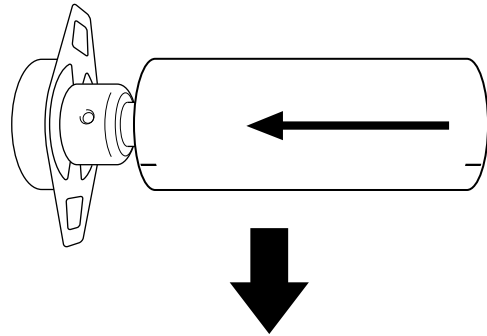

- 4** Place the **media feeder spindle** loaded with media roll on the **media feeder tray** so that it fits in the bearings.

Make sure that the print side is facing up.

- 5** Refer to steps 1 through 5 of [Section 3.4.1 Loading Fan-fold Media](#) to load the media through the product.

- 6** After loading the media and ribbon, perform a test print to make sure that the media is loaded correctly.

Refer to the [Section 4.2.11 Test Print Mode](#) for details on how to perform a test print.

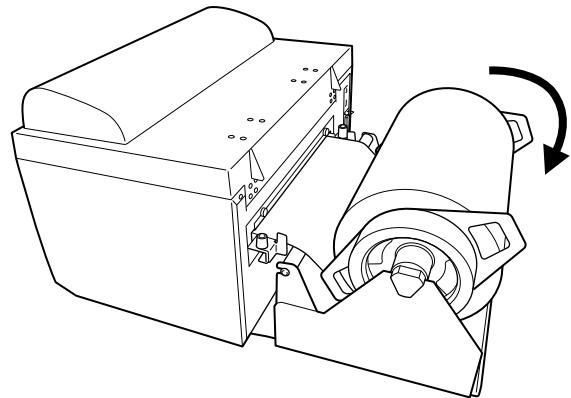

### 3.4.3 Using Cutter

When cutter is used, after setting the media, pull out the media tray as necessary. The cut media can be collected and stacked neatly on the tray.

#### Media size that can be stacked on the media tray

Length: 40 to 117 mm (43 to 120 mm)\*  
1.6" to 16.5" (1.7" to 16.6")\*

Width: 128 to 297 mm (131 to 300 mm)\*  
5.0" to 11.7" (5.2" to 11.8")\*

\* ( ) is the maximum size including liner  
Maximum stack height: 5 mm (0.2") (approx. 40 sheets, 0.12 mm (0.008") thick/sheet)





# 4

## Operation and Configuration

### 4.1 Display and Operation

The display of the product varies depending on the following modes:

- Normal mode: refer to [Section 4.1.1 Normal Mode Display and Icons](#).
- Setting mode menu: refer to [Section 4.1.2 Setting Mode Menu and Icons](#).
- Error display: refer to [Section 4.1.3 Error Display and Icons](#).
- Setting display: refer to [Section 4.1.4 Setting Display](#).

#### 4.1.1 Normal Mode Display and Icons

In normal mode, the screen shows the following product status.

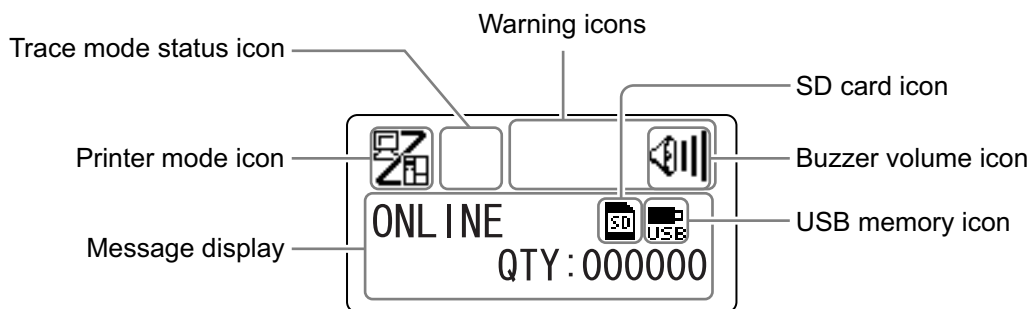



- Printer mode

Icon	Description
	Shows when the product is in online mode.
	Shows when the product is in offline mode.
	Shows when the product is in test print mode and hex dump print mode.
	Shows when the product is in download mode.
	Shows when the product is in upload mode.
	Shows when the product is in memory mode.





## 4 Operation and Configuration

---





- Trace mode status

Icon	Description
 RCU	Shows after receiving any data while trace mode is ENABLE.
 EDIT	Shows after receiving ESC (1BH) A while trace mode is ENABLE.
 PRT	Shows after print operation while trace mode is ENABLE.



- Buzzer volume

Icon	Description
	Shows when the volume is level 3 (Loud).
	Shows when the volume is level 2 (Medium).
	Shows when the volume is level 1 (Low).
	Shows when the volume is level 0 (Mute).

- Warning Icons

Icon	Description
	Shows when a ribbon “near end” is detected.
	Shows when a command error is detected.
	Shows when a receive buffer “near full” is detected.
	Shows when print head damage is detected.

- Memory card status

Icon	Description
	Shows when an SD card is inserted.
	Shows when a USB memory is inserted.
<p><b>Note</b></p> <ul style="list-style-type: none"><li>• These icons show when the SD card or USB memory is connected.</li><li>• These icons do not show when the product is in an error mode.</li><li>• These icons do not show when the trace mode is enabled.</li><li>• These icons do not show when the ESC+IM command (for specifying LCD display) is in use.</li><li>• These icon colors are inverted when the SD card or USB memory is being accessed.</li></ul>	

## 4.1.2 Setting Mode Menu and Icons

In the setting mode menu, the screen is shown as follows.

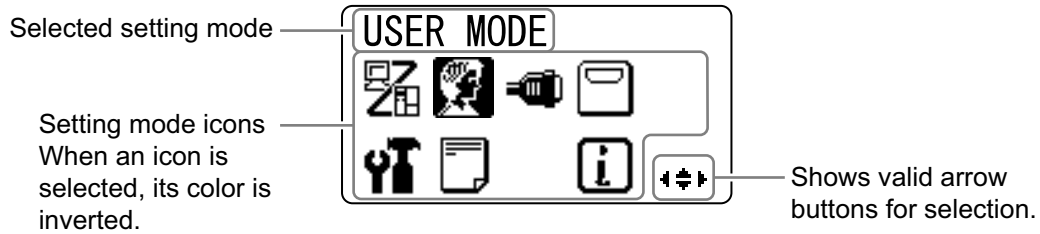

Refer to [Section 4.2.4 Settings Mode Menu](#) for more details.

- Setting Mode

Icon	Description
	The product enters the normal mode.
	The product enters the user mode.
	The product enters the interface mode.
	The product enters the memory mode.
	The product enters the advanced mode.
	The product enters the hex dump print mode.
	The product enters the product information mode.



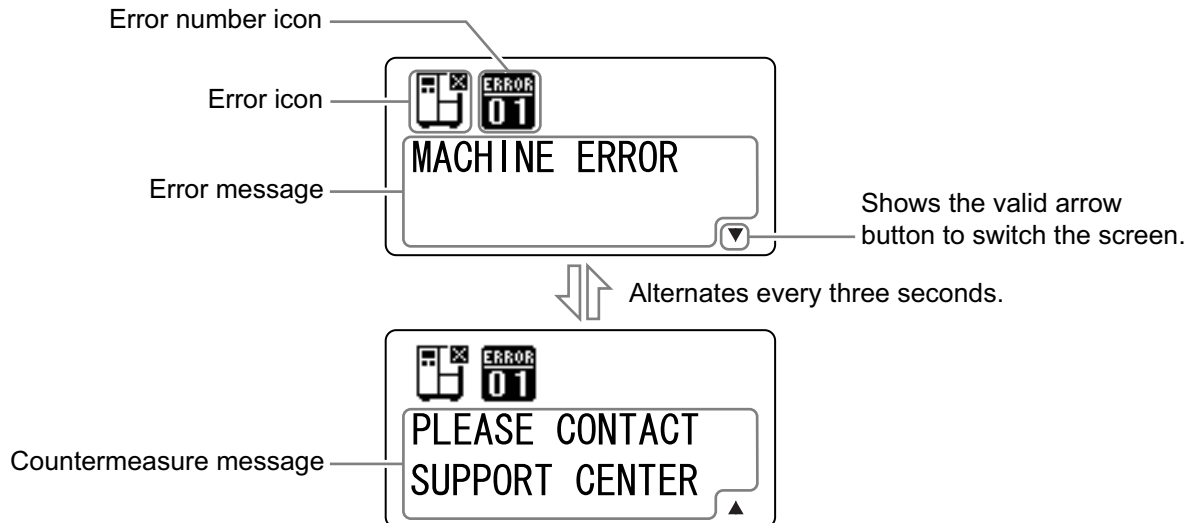

### 4.1.3 Error Display and Icons

When an error occurs, the screen shows the following error messages and icons.



- Error Icon

Icon	Description
	Label end or media end is detected.
	Ribbon end is detected.
	Sensor error is detected.
	Print head is unlocked.
	Filament disconnection of the print head is detected.
	Communication error is detected.
	Receive buffer over is detected.
	Item No. error or BCC error is detected.
	Cutter error is detected.
	Memory card is not accessible or there is no free space in the memory card.

Icon	Description
	Writing to the ROM failed or kanji memory error is detected.
	Calendar error is detected.
	Any error of the product other than above is detected.
	Error number according to the errors.

### 4.1.4 Setting Display

In various setting mode, the setting display is shown as follows. This section also describes the functions of the buttons in setting mode.

- **Selecting vertical item**

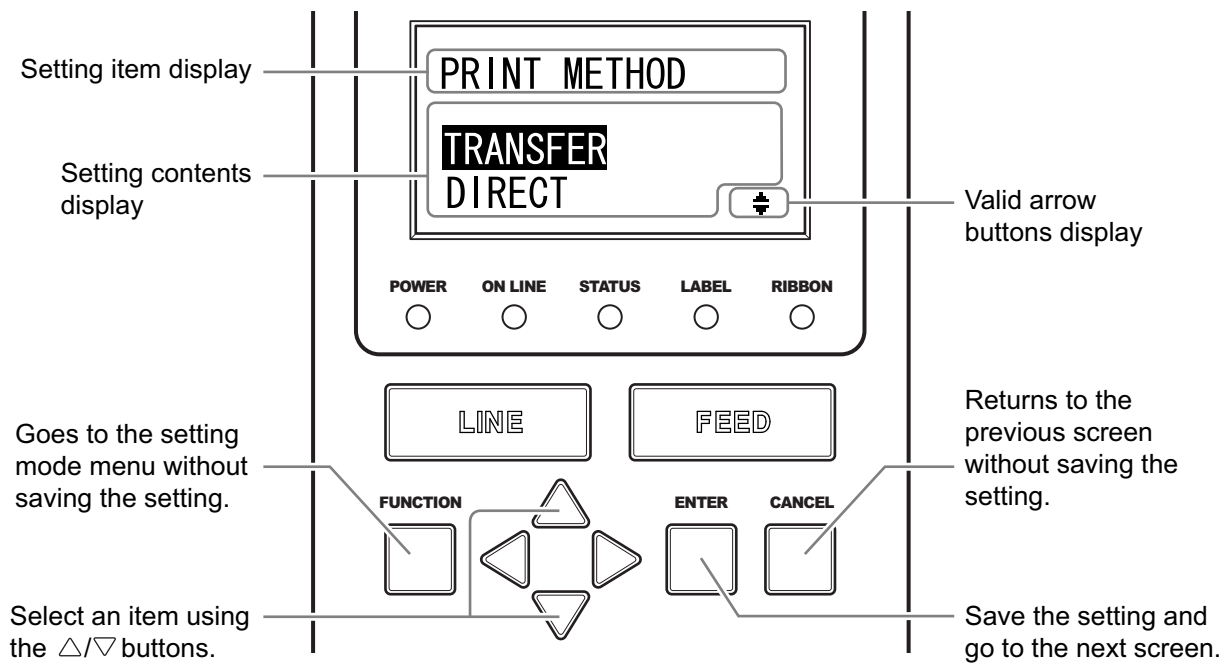

• **Selecting horizontal item**

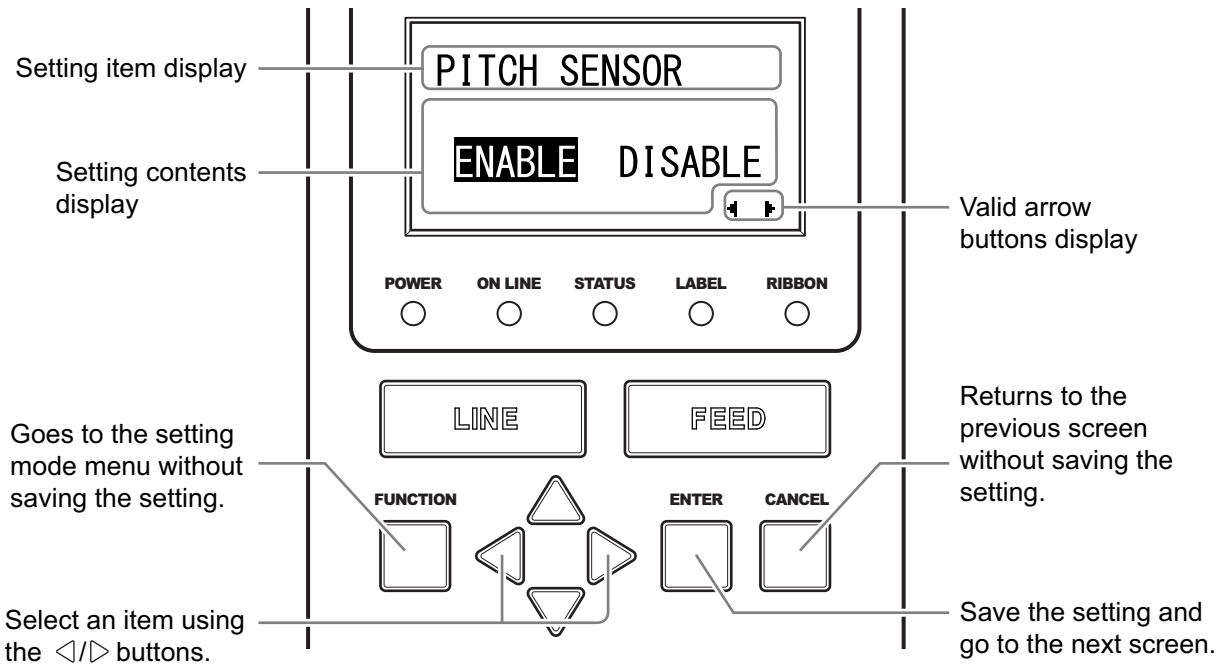

• **Setting values**

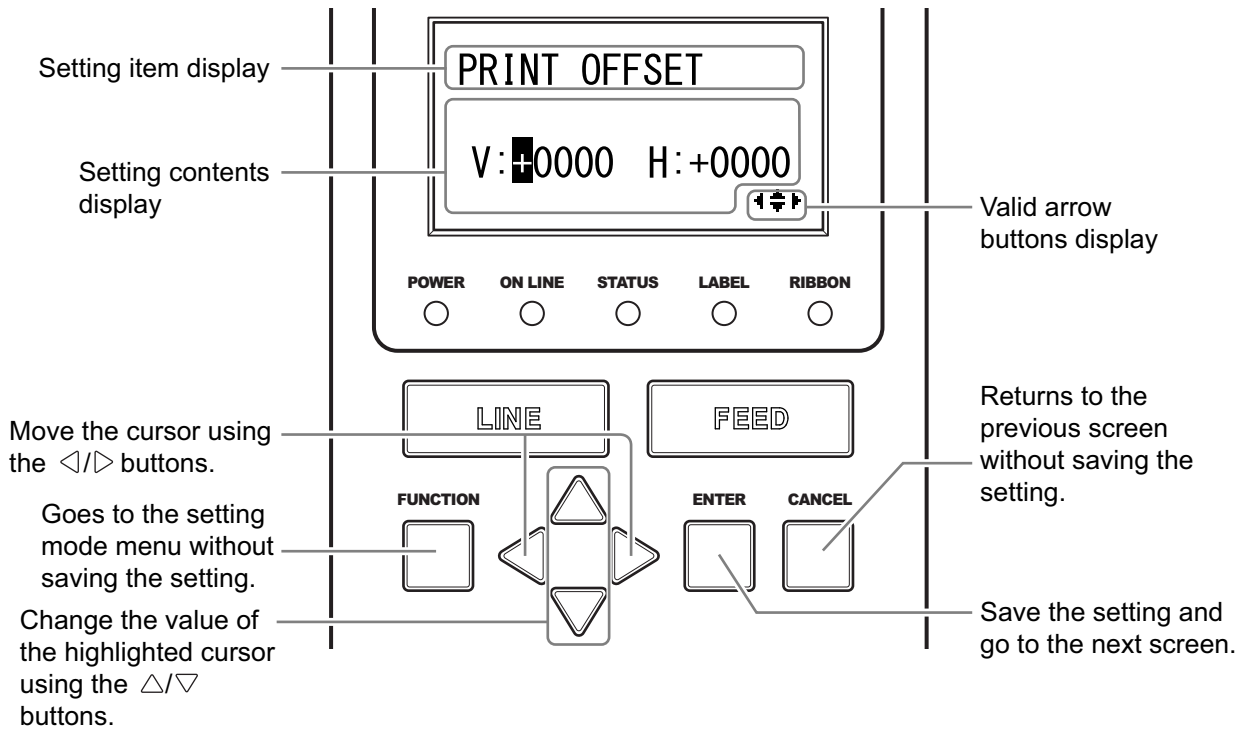

## 4.2 Operating Modes

The product contains a variety of the following operating modes:

Click on the blue links below to go directly to the details of the selected operating mode.

- [Online Mode/Pause Mode/Offline Mode](#)
- [Canceling the Print Job](#)
- [Adjustment Mode](#)
- [Settings Mode Menu:](#)
  - [User Mode](#)
  - [Interface Mode](#)
  - [Memory Mode](#)
  - [Advanced Mode](#)
  - [Hex Dump Mode](#)
  - [Information Mode](#)
- [Test Print Mode](#)
- [Default Setting Mode](#)
- [Download Mode](#)
- [Upload Mode](#)



The flowchart provides a clear summary of all the modes and their access methods.

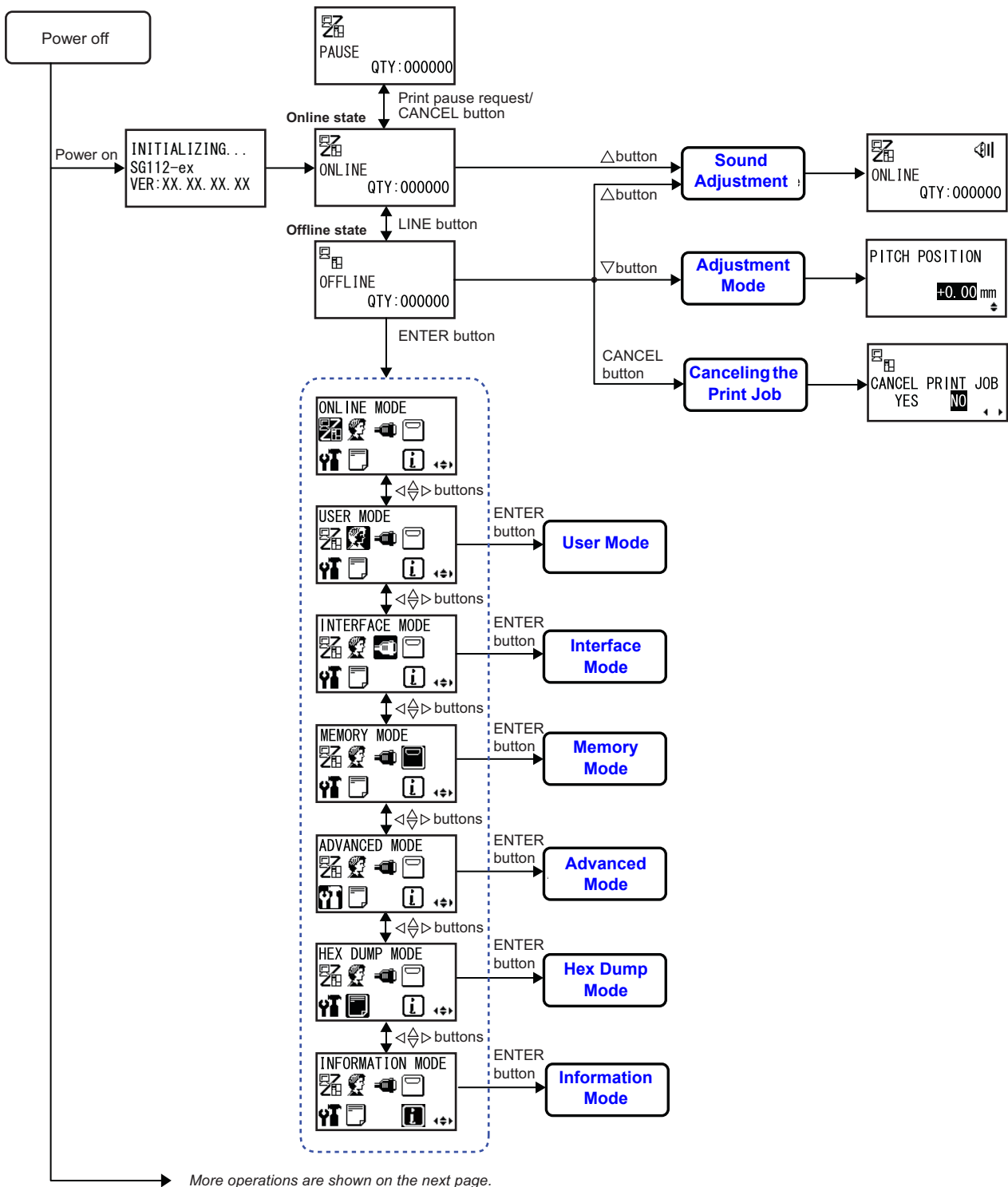

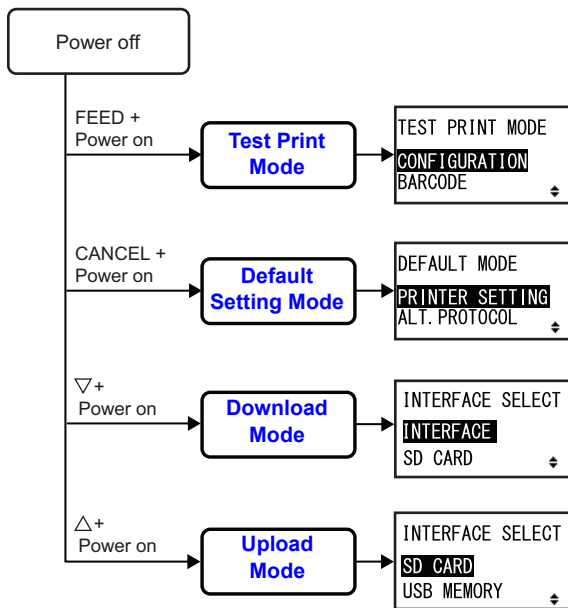

### 4.2.1 Online Mode/Pause Mode/Offline Mode

In online mode, the product is ready to receive print data from the host computer or other connected devices and start the print job.

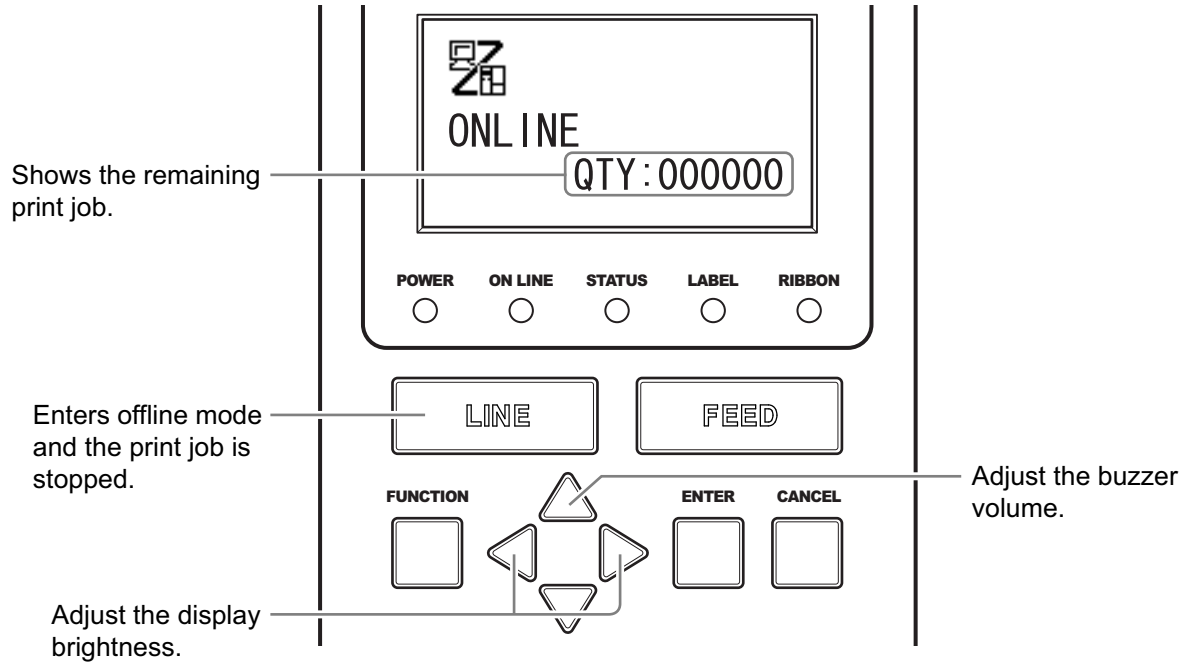

## 4 Operation and Configuration

When you send a pause command during printing, the product stops the print job and enters pause mode.

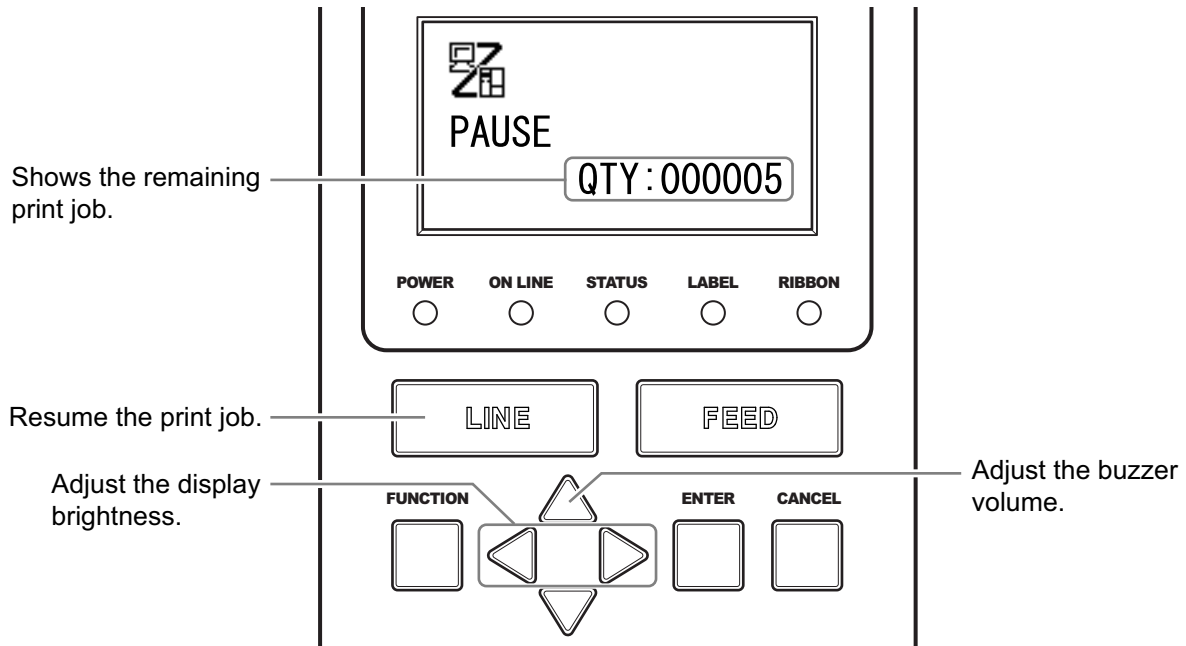

In offline mode, you can cancel the print job, feed the media or enter the setting mode menu.

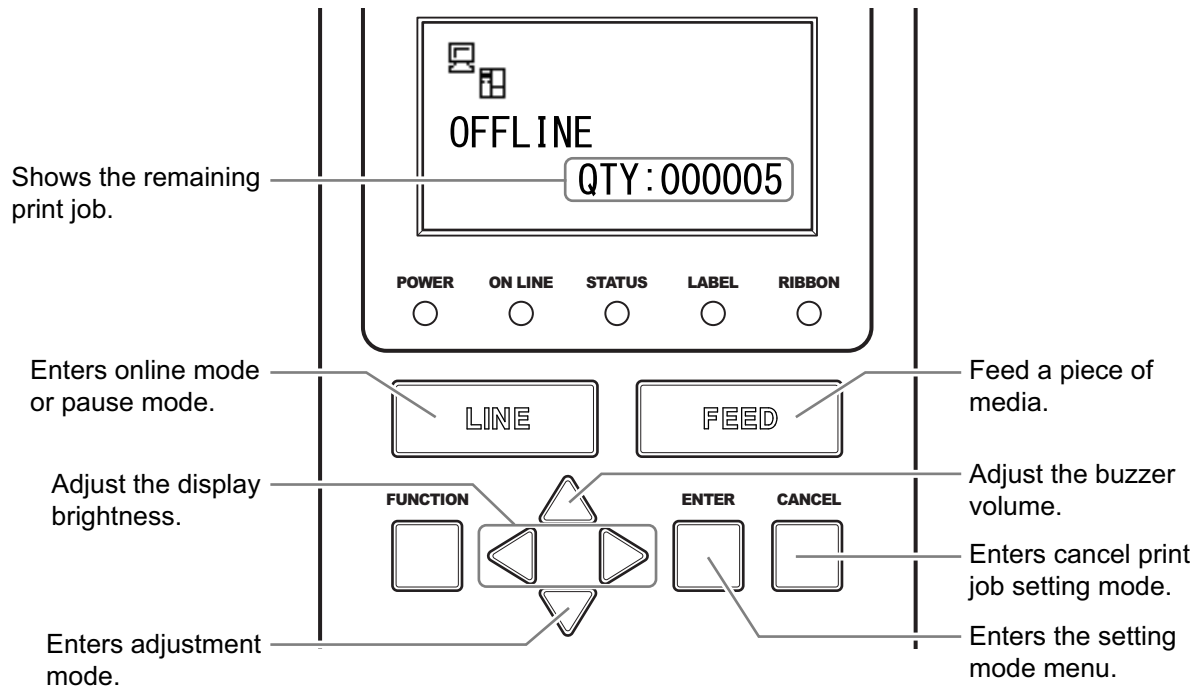

## 4.2.2 Canceling the Print Job

Cancel the print job according to the following procedure. When the print job is canceled, the data stored in the receive buffer of the product is also deleted.

- 1 Press the **LINE** button to change the product to offline mode.

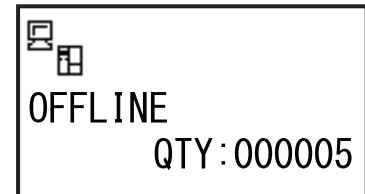

- 2 Press the **CANCEL** button.

CANCEL PRINT JOB shows, confirming that you want to cancel the print job.

- 3 Press the  $\triangleleft/\triangleright$  buttons to select YES.

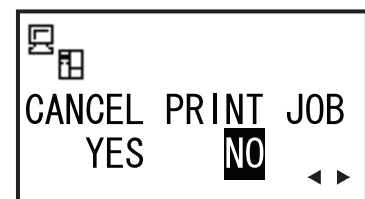

### Note

- Be sure you want to cancel the print job before selecting YES. The job cannot be recovered and it has to be transmitted to the product again.
- Press the **FUNCTION** button or **CANCEL** button to exit the CANCEL PRINT JOB mode without clearing the print data.

- 4 Press the **ENTER** button to confirm.

CANCEL PRINT JOB COMPLETED shows with three beeps sound. The product then enters to offline mode. The print job is canceled.

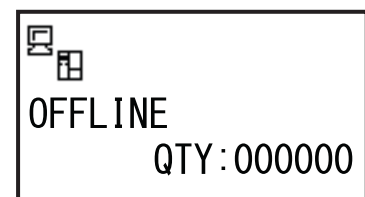

### 4.2.3 Adjustment Mode

The product has a quick access to the adjustment mode for setting the print position, stop position and print darkness. These adjustments are in conjunction with the configuration adjustments performed in the user mode menu.

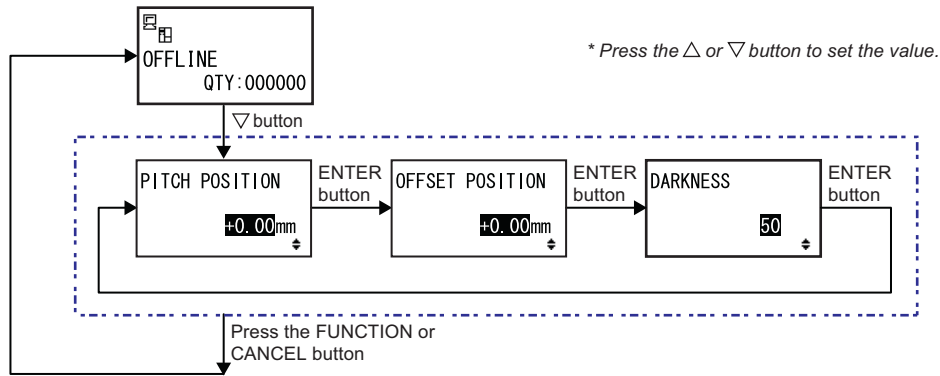

- 1 When the product is in offline mode, press the  $\nabla$  button to enter the adjustment mode. PITCH POSITION shows on the screen.
- 2 Press the  $\Delta/\nabla$  buttons to set the desired value and press the **ENTER** button to save the setting and proceed to the next adjustment screen.

<b>PITCH POSITION</b>	
<p>Offset the print start position in the vertical direction. Set the offset value with '+' to move the print position opposite the feed direction and value with '-' to move the print position in the feed direction. The setting value is adjustable by 0.25 mm (0.01") regardless of the print resolution. The setting range is from -3.75 mm (-0.15") to +3.75 mm (+0.15").</p>	<div style="border: 1px solid black; padding: 10px; width: fit-content; margin: 0 auto;"> <p>PITCH POSITION</p> <p style="font-size: 1.2em; font-weight: bold;">+0.00mm</p> <p style="text-align: right; font-size: 0.8em;">↕</p> </div>

<b>OFFSET POSITON</b>	
<p>Correct the offset position. Offset position refers to the stop or cut position of each media after printing. Set the offset value with '+' to move the stop position opposite the feed direction and value with '-' to move the stop position in the feed direction. The setting value is adjustable by 0.25 mm (0.01") regardless of the print resolution. The setting range is from -3.75 mm (-0.15") to +3.75 mm (+0.15").</p>	<div style="border: 1px solid black; padding: 10px; width: fit-content; margin: 0 auto;"> <p>OFFSET POSITION</p> <p style="font-size: 1.2em; font-weight: bold;">+0.00mm</p> <p style="text-align: right; font-size: 0.8em;">↕</p> </div>

DARKNESS	
<p>Fine tune the print darkness. The setting range is from 00 to 99. 00 is the lightest and 99 is the darkest.</p>	 A screenshot of a menu titled "DARKNESS". The menu shows the number "50" in a small box, with a vertical cursor bar to its right. The word "DARKNESS" is printed at the top of the menu area.

- 3 After adjustment, press the **FUNCTION** button or **CANCEL** button to exit the adjustment mode. The product enters offline mode.

---

**Note**







Pressing the **FUNCTION** button or **CANCEL** button before pressing the **ENTER** button will not save the adjustment.

---

- 4 Perform a test print after completing the adjustments to make sure that the settings are correct.  
Refer to [Section 4.2.11 Test Print Mode](#) for details.

## 4.2.4 Settings Mode Menu

In the settings mode menu, you can select the setting modes as follows:

Menu	Description
 Online mode	Returns to online mode.
 User mode	Access the settings related to the basic user configurations.
 Interface mode	Access the settings related to the interfaces.
 Memory mode	Access the settings related to the memory.
 Advanced mode	Access the settings related to the advanced configurations of the product.
 Hex dump mode	Access and print the hex dump for troubleshooting.
 Information mode	Access the information of this product.

- 1 Press the **LINE** button to change the product to offline mode.  
The product changes to offline mode.

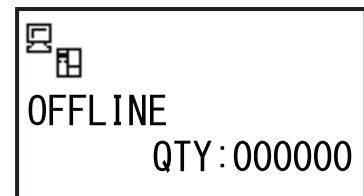

- 2 Press the **ENTER** button.  
The product changes to the settings mode menu.

- 3 Select the setting mode using the  $\Delta/\nabla/\leftarrow/\rightarrow$  buttons.  
The selected setting mode shows on the screen and the icon is highlighted by inverting its colors.



- 4 Press the **ENTER** button to enter the selected mode.



The functions of the buttons in the settings mode menu are shown as below.

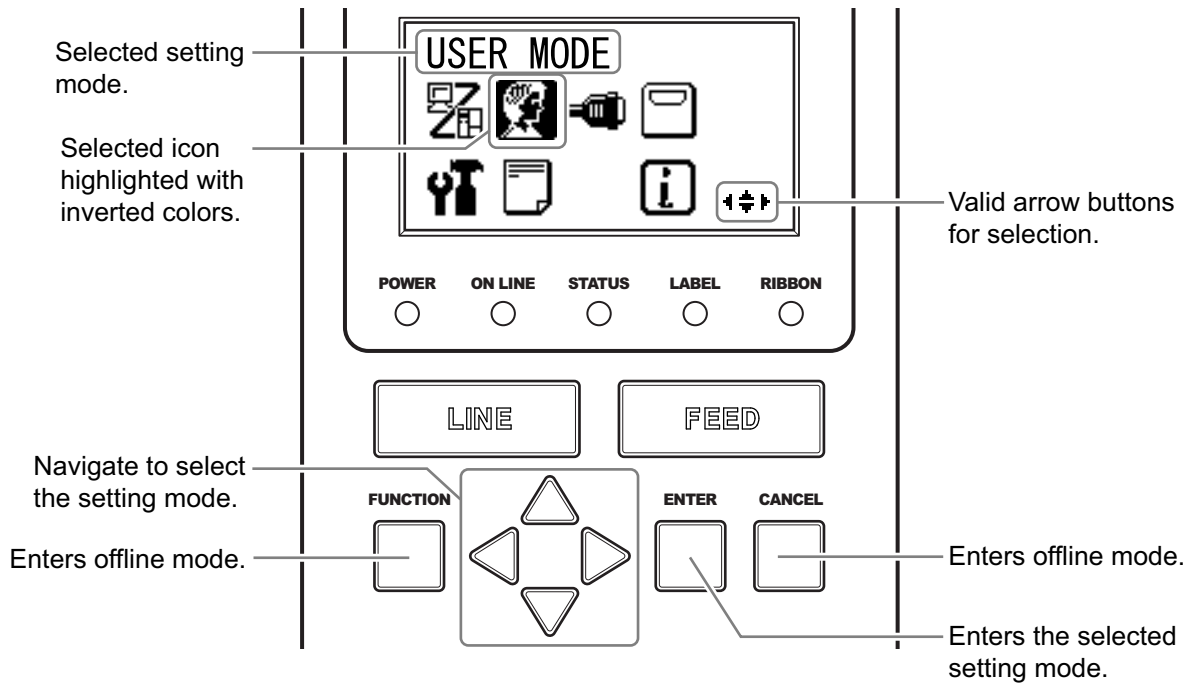

## 4.2.5 User Mode

The flowchart shows the sequence of the setting screens for the user mode. The table describes each setting screen in detail.

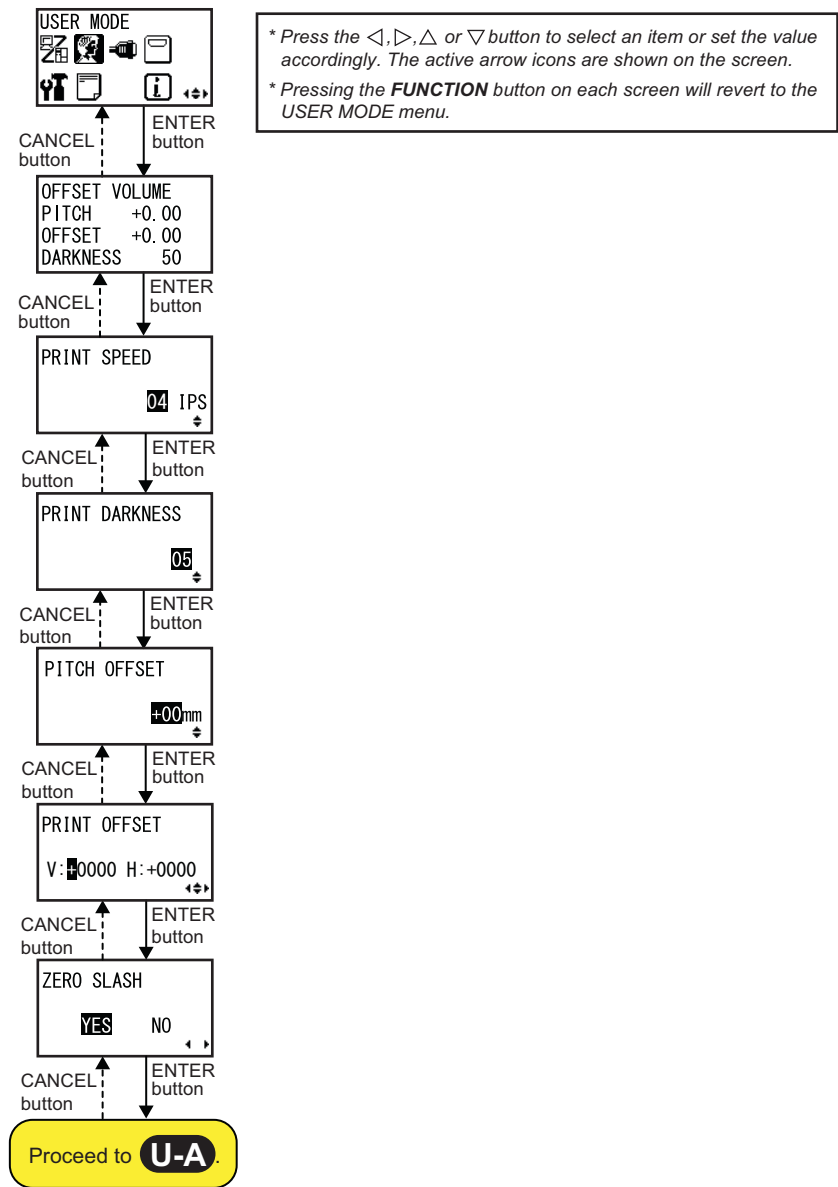

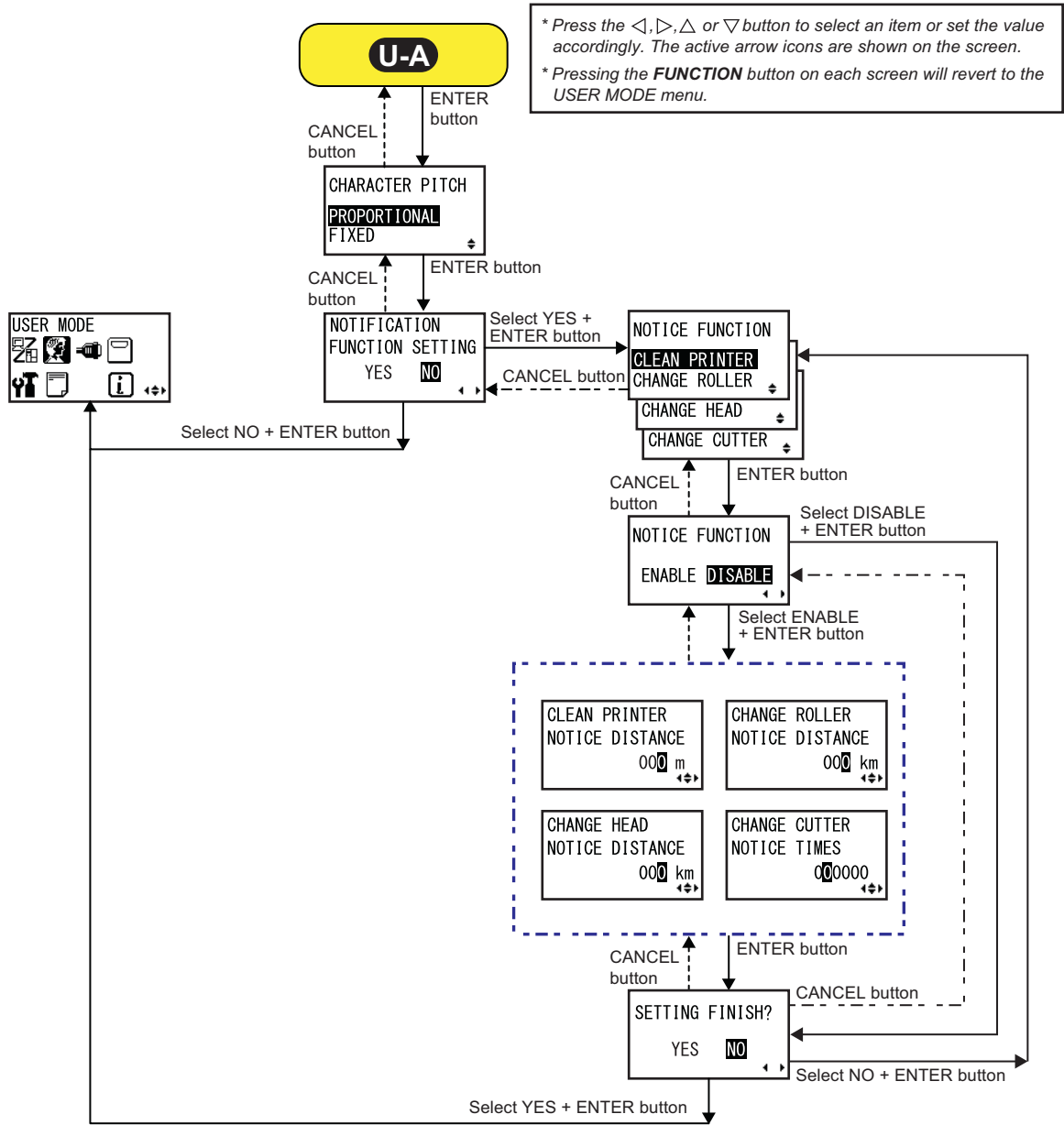

OFFSET VOLUME	
<p>The setting values of the adjustment mode are shown.</p> <ul style="list-style-type: none"> <li>• <b>PITCH:</b> Shows the print position offset value.</li> <li>• <b>OFFSET:</b> Shows the stop position offset value.</li> <li>• <b>DARKNESS:</b> Shows the darkness setting value.</li> </ul> <p>You can change these values in <b>Adjustment Mode</b> and <b>Test Print Mode</b>.</p>	<div style="border: 1px solid black; padding: 5px;"> <p>OFFSET VOLUME</p> <p>PITCH    +0.00</p> <p>OFFSET    +0.00</p> <p>DARKNESS    50</p> </div>

PRINT SPEED	
<p>Adjusts the print speed. The setting range is from 03 IPS to 06 IPS (inches/sec).</p> <hr/> <p><b>Note</b> Setting the print speed to a level that is too fast may affect the print quality.</p>	<div style="border: 1px solid black; padding: 5px;"> <p>PRINT SPEED</p> <p style="text-align: right; font-size: 1.2em;"><b>04</b> IPS</p> <p style="text-align: right;">⬇</p> </div>

PRINT DARKNESS	
<p>Specify the print darkness from ten steps. The setting range is from 1 to 10. 1 is the lightest and 10 is the darkest.</p>	<div style="border: 1px solid black; padding: 5px;"> <p>PRINT DARKNESS</p> <p style="text-align: right; font-size: 1.2em;"><b>05</b></p> <p style="text-align: right;">⬇</p> </div>

PITCH OFFSET	
<p>This setting adjusts the pitch offset value. The media pitch is the distance between the leading edge (the edge that comes out of the product first) of the media and the leading edge of the next media. Once the position has been set, it can be fine adjusted using the PITCH POSITION in adjustment mode. The setting range is from -49 mm (-1.9") to +49 mm (+1.9") and is adjustable by 1 mm (0.04") steps. Set the offset value with '+' to move the print position opposite the feed direction and value with '-' to move the print position in the feed direction.</p>	<div style="border: 1px solid black; padding: 5px;"> <p>PITCH OFFSET</p> <p style="text-align: right; font-size: 1.2em;"><b>+00</b>mm</p> <p style="text-align: right;">⬇</p> </div>

PRINT OFFSET	
<p>Print Position Offset — which refers to the vertical and horizontal shifting of the entire print area, relative to the start position of printing (V=0, H=0), defined by default to be the bottom right hand corner of the media.</p> <p>When setting the print position in the vertical direction “V”: Set the offset value with '+' from the print reference position to move the print position opposite the feed direction and value with '-' to move the print position in the feed direction.</p> <p>When setting the print position in the horizontal direction “H”: Set the offset value with '+' from the print reference position to move to the left side and value with '-' to move to the right side of the product (when facing the front of the product).</p> <p>The setting range is as follows: V: ±0 to 5040 dot      H: ±0 to 3200 dot</p>	<div style="border: 1px solid black; padding: 5px; margin-bottom: 10px;"> <p>PRINT OFFSET</p> <p>V: <input type="text" value="0000"/> H: <input type="text" value="+0000"/></p> </div>

ZERO SLASH	
<p>Set whether to print the number zero (0) with or without a slash (/).</p> <ul style="list-style-type: none"> <li>• <b>YES</b>: Print zero with a slash.</li> <li>• <b>NO</b>: Print zero without a slash.</li> </ul> <p>Applicable to X21, X22, X23, X24, XU, XM, XS, XB, XL fonts.</p>	<div style="border: 1px solid black; padding: 5px;"> <p>ZERO SLASH</p> <p><input checked="" type="checkbox"/> YES    <input type="checkbox"/> NO</p> </div>

CHARACTER PITCH	
<p>Set the character width for printing.</p> <ul style="list-style-type: none"> <li>• <b>PROPORTIONAL</b>: Print each character with a different width.</li> <li>• <b>FIXED</b>: Print all characters with the same width.</li> </ul>	<div style="border: 1px solid black; padding: 5px;"> <p>CHARACTER PITCH</p> <p><input checked="" type="checkbox"/> PROPORTIONAL</p> <p><input type="checkbox"/> FIXED</p> </div>

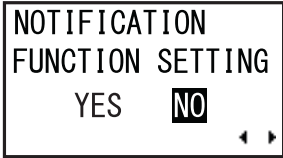
NOTIFICATION FUNCTION SETTING	
<p>Select whether or not to set the notification function.</p> <ul style="list-style-type: none"> <li>• <b>YES:</b> Set the notification function.</li> <li>• <b>NO:</b> Do not set the notification function. The screen returns to user mode.</li> </ul> <hr/> <p><b>Note</b> For details on the media motion when the set notification interval has reached, refer to <a href="#">Section 8.4 Notification Function</a>.</p>	

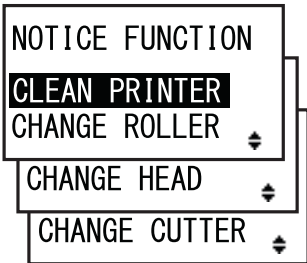
NOTICE FUNCTION (SELECT)	
<p>Select the items for notification.</p> <ul style="list-style-type: none"> <li>• <b>CLEAN PRINTER:</b> Notify when the product needs to be cleaned.</li> <li>• <b>CHANGE ROLLER:</b> Notify when the platen roller needs to be replaced.</li> <li>• <b>CHANGE HEAD:</b> Notify when the print head needs to be replaced.</li> <li>• <b>CHANGE CUTTER:</b> Notify when the cutter unit needs to be replaced.</li> </ul>	

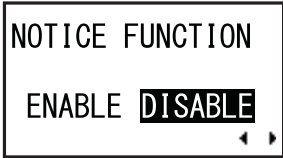
NOTICE FUNCTION (ENABLE/DISABLE)	
<p>Enable or disable the notification for the item selected in the above NOTICE FUNCTION.</p> <ul style="list-style-type: none"> <li>• <b>ENABLE:</b> Enable the notification function.</li> <li>• <b>DISABLE:</b> Disable the notification function.</li> </ul>	

CLEAN PRINTER	
<p>Set the notification interval (in printed distance) about when the product needs to be cleaned. The setting range is from 000 to 999 m.</p> <hr/> <p><b>Note</b> The notification function will be disabled if the distance is set to 0.</p>	

**CHANGE ROLLER**

Set the notification interval (in printed distance) about when the platen roller needs to be replaced.

The setting range is from 000 to 999 km.

**Note**

The notification function will be disabled if the distance is set to 0.

CHANGE ROLLER  
NOTICE DISTANCE  
000 km

**CHANGE HEAD**

Set the notification interval (in printed distance) about when the print head needs to be replaced.

The setting range is from 000 to 999 km.

**Note**

The notification function will be disabled if the distance is set to 0.

CHANGE HEAD  
NOTICE DISTANCE  
000 km

**CHANGE CUTTER**

Set the notification interval (in number of cuts) about when the cutter unit needs to be replaced.

The setting range is from 000000 to 990000 cuts.

**Note**

The notification function will be disabled if the distance is set to 0.

CHANGE CUTTER  
NOTICE TIMES  
000000

**SETTING FINISH?**

Confirm to complete the setting.

- **YES:** Returns to the user mode screen.
- **NO:** Returns to the NOTICE FUNCTION screen to select an item.

SETTING FINISH?  
YES NO

## 4.2.6 Interface Mode

The flowchart shows the sequence of the setting screens for the interface mode. The table describes each setting screen in detail.

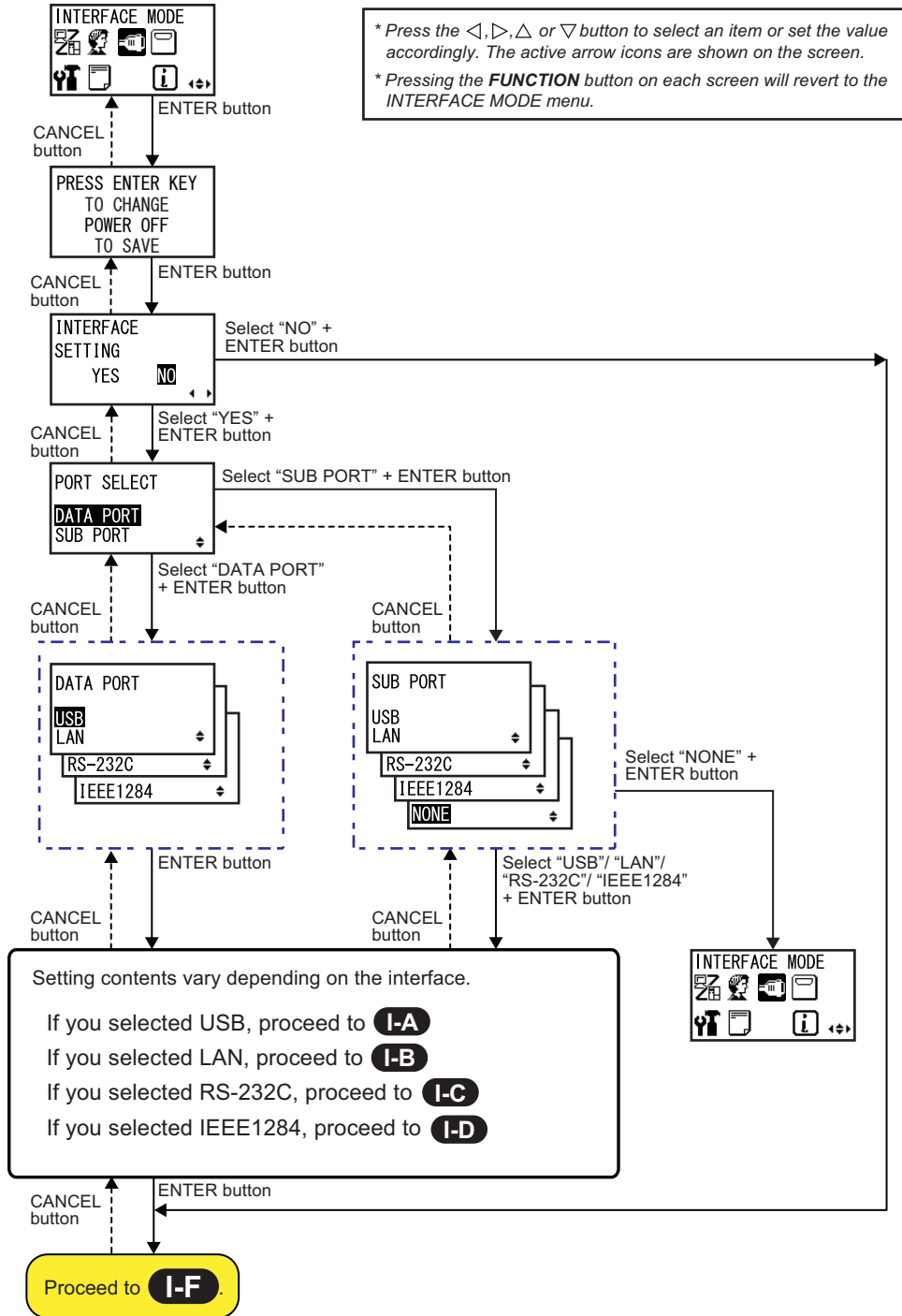



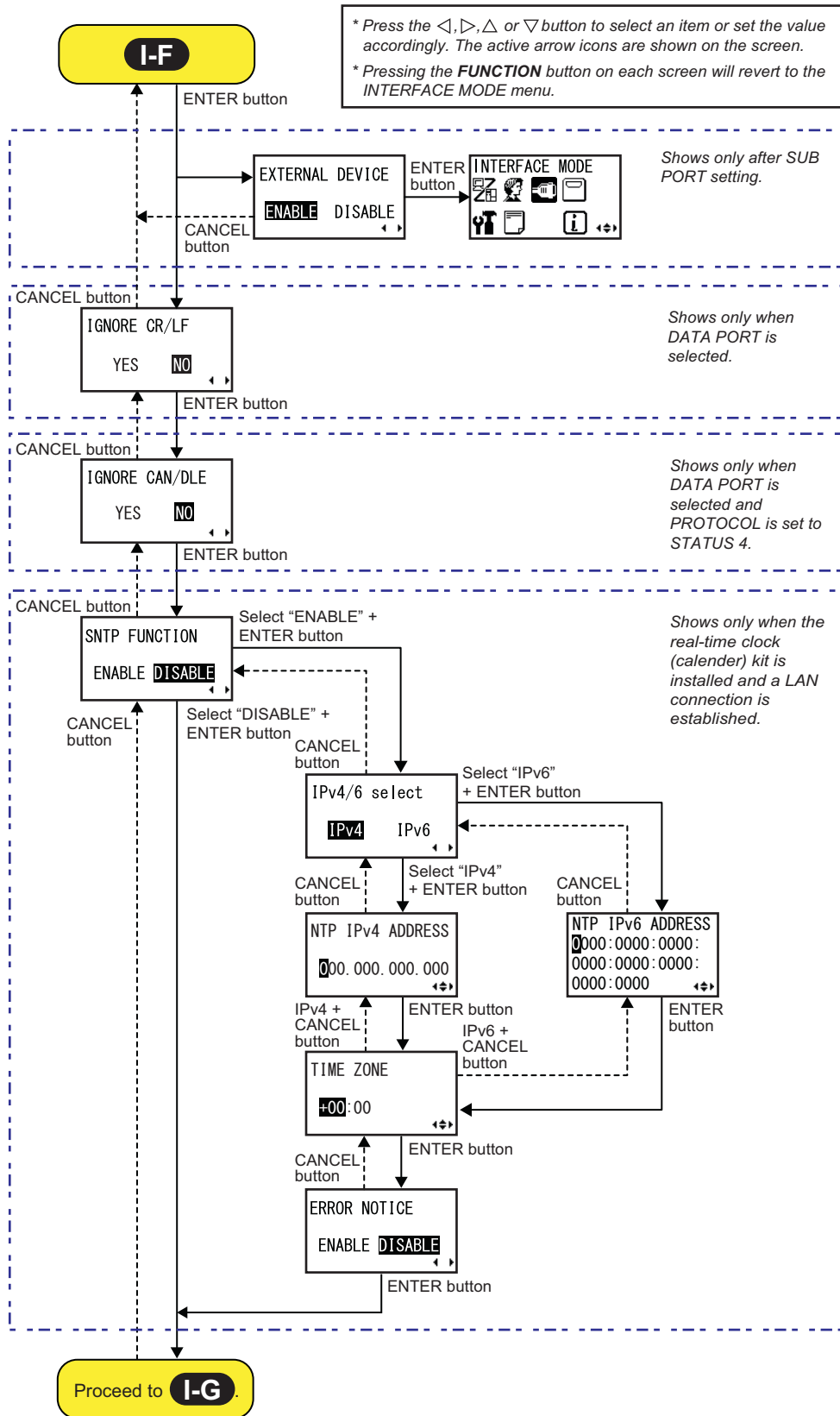

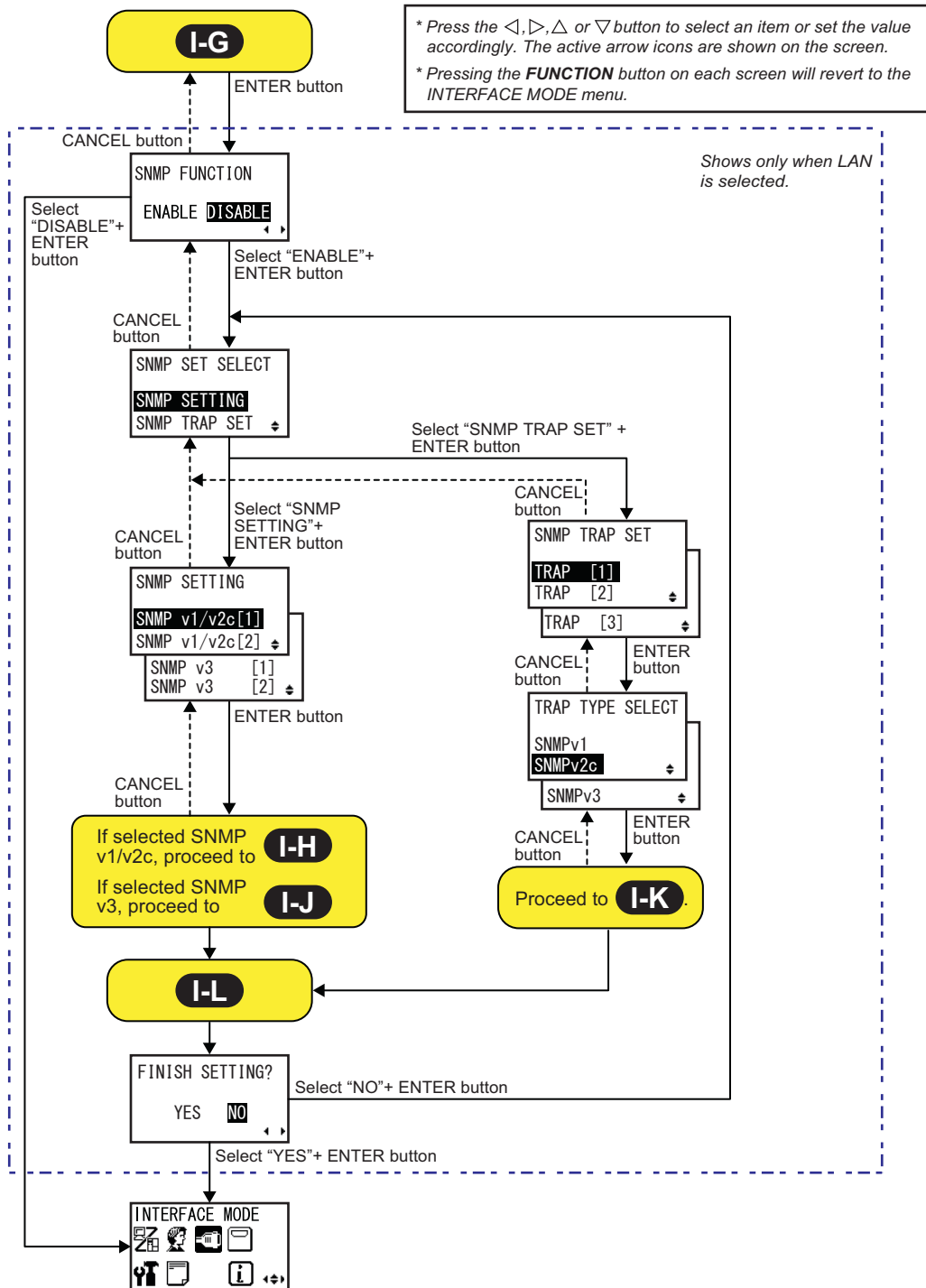

\* Press the  $\triangleleft$ ,  $\triangleright$ ,  $\triangle$  or  $\nabla$  button to select an item or set the value accordingly. The active arrow icons are shown on the screen.  
 \* Pressing the **FUNCTION** button on each screen will revert to the **INTERFACE MODE** menu.

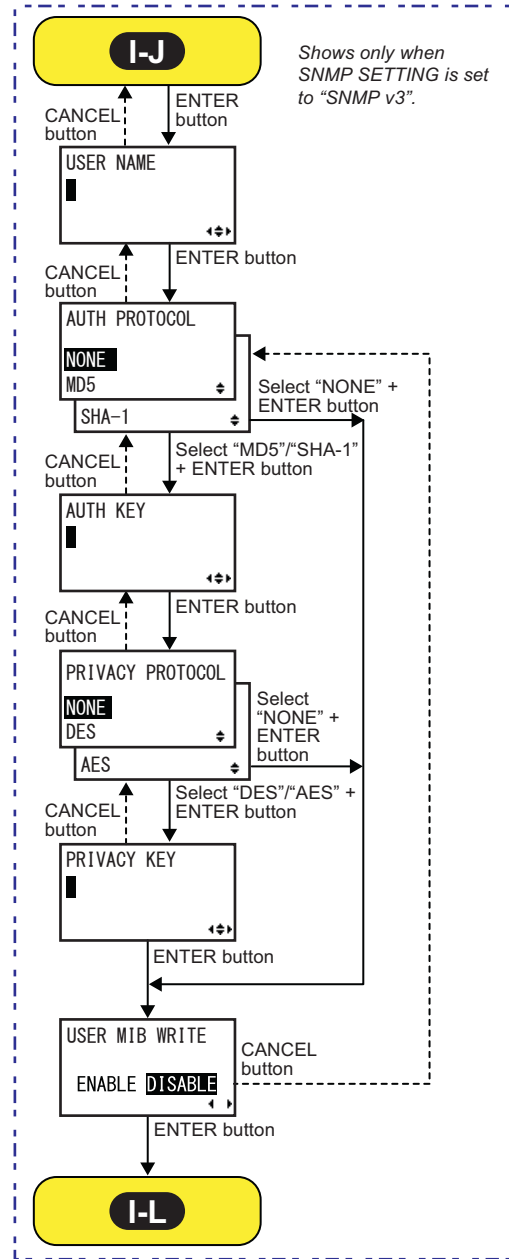
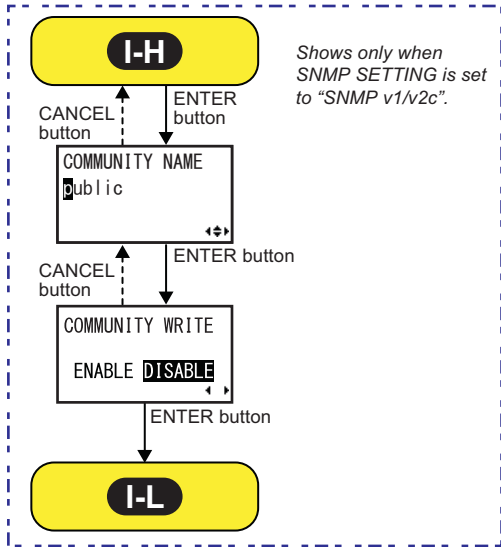

## 4 Operation and Configuration

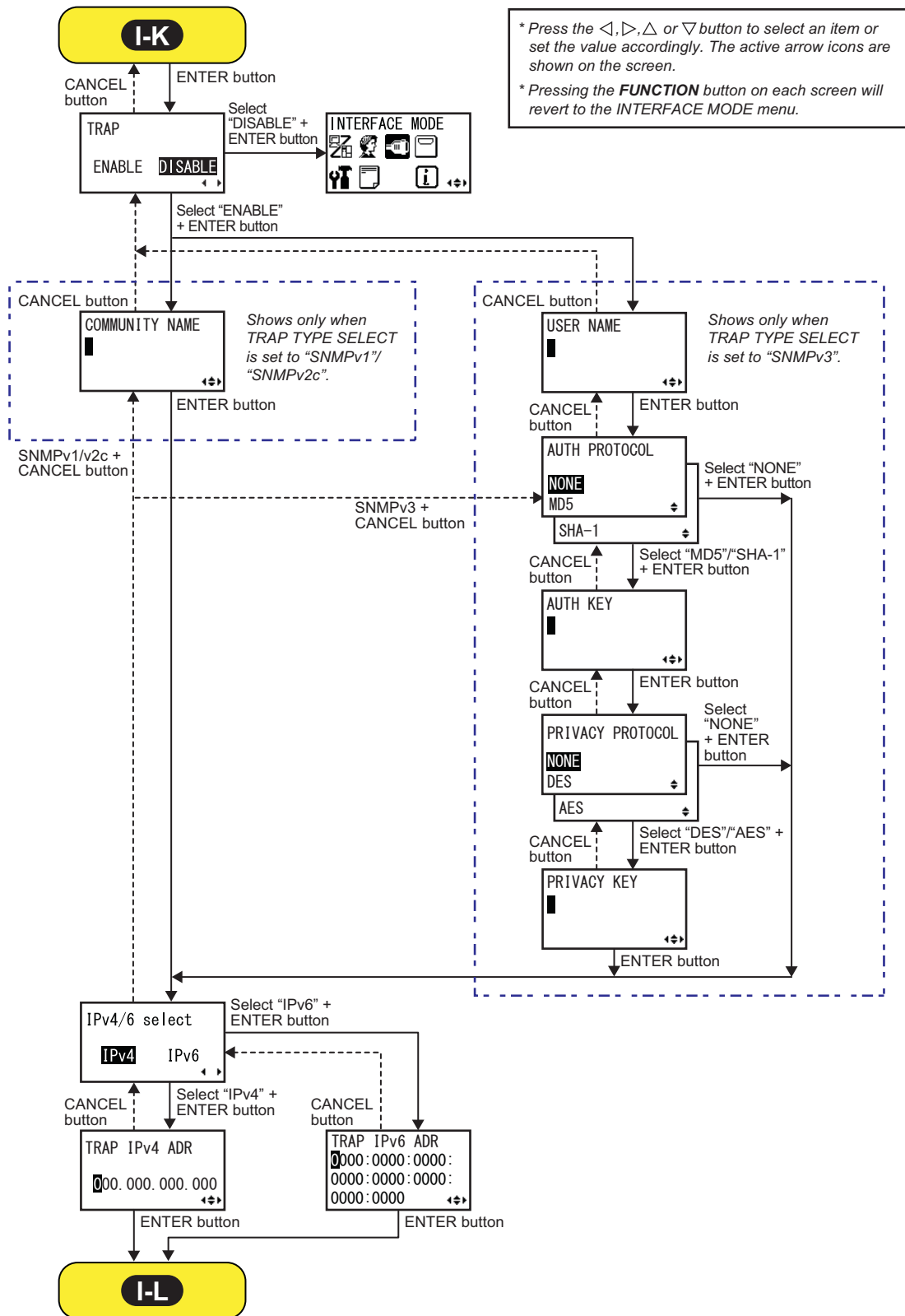

**PRESS ENTER KEY**

This screen reminds the user to press the **ENTER** button to change or power off the product to save the updated setting.

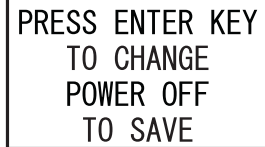

PRESS ENTER KEY  
TO CHANGE  
POWER OFF  
TO SAVE

**INTERFACE SETTING**

Set whether or not to perform the interface settings.

- **YES:** Enter the PORT SELECT screen.
- **NO:** Enter the IGNORE CR/LF screen.

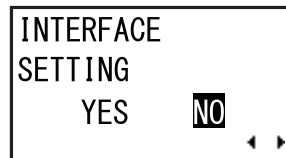

INTERFACE  
SETTING  
YES **NO**

**PORT SELECT**

Select the port used for the connected interface.

- **DATA PORT:** For receiving various SBPL commands and executing print operations.
- **SUB PORT:** For monitoring the printer status and connecting to external devices.



PORT SELECT  
**DATA PORT**  
SUB PORT

**DATA PORT**

Select the connected interface for use with the data port.

The options are as follows:

- **USB**
- **LAN**
- **RS-232C**
- **IEEE1284**

**Note**

- You cannot select the interface that has already been set for the SUB PORT.
- The setting will be effective only if you power on the product again.

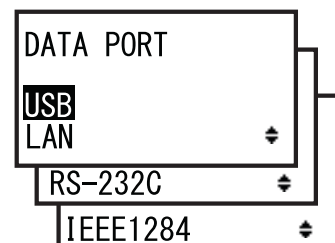

DATA PORT  
**USB**  
LAN  
RS-232C  
IEEE1284

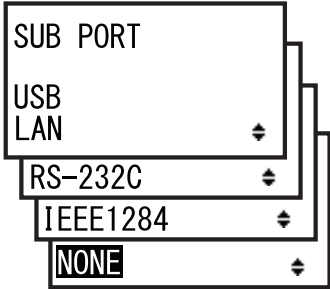
SUB PORT	
<p>Select the connected interface for use with the sub port. The options are as follows:</p> <ul style="list-style-type: none"> <li>• <b>USB</b></li> <li>• <b>LAN</b></li> <li>• <b>RS-232C</b></li> <li>• <b>IEEE1284</b></li> <li>• <b>NONE</b></li> </ul> <hr/> <p><b>Note</b></p> <ul style="list-style-type: none"> <li>• You cannot select the interface that has already been set for the DATA PORT.</li> <li>• The setting will be effective only if you power on the product again.</li> </ul>	

EXTERNAL DEVICE	
<p>Enable or disable the connection between the sub port and the external device.</p> <ul style="list-style-type: none"> <li>• <b>ENABLE</b>: Connecting the sub port and the external device. It's possible to import the data from the external port into the print data by using in the combination with an extended command.</li> <li>• <b>DISABLE</b>: Not connecting the sub port and the external device. It's possible to monitor the product status.</li> </ul> <hr/> <p><b>Note</b></p> <p>Shows only after changing SUB PORT setting.</p>	

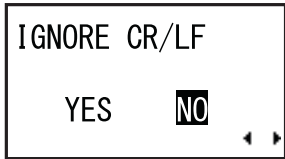
IGNORE CR/LF	
<p>Ignore or acknowledge the CR/LF code of the received data.</p> <ul style="list-style-type: none"> <li>• <b>YES</b>: Ignore the CR/LF code.</li> <li>• <b>NO</b>: Do not ignore the CR/LF code.</li> </ul> <hr/> <p><b>Note</b></p> <p>Shows only if the DATA PORT is selected.</p>	

**IGNORE CAN/DLE**

Ignore or acknowledge the CAN/DLE code of the received data.

- **YES**: Ignore the CAN/DLE code.
- **NO**: Do not ignore the CAN/DLE code.

**Note**

Shows only if the DATA PORT is selected and PROTOCOL is set to STATUS4.

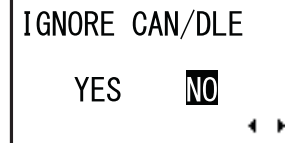
**SNTP FUNCTION**

Enable or disable the SNTP function.

- **ENABLE**: Perform the time correction of the calendar.
- **DISABLE**: Do not perform the time correction of the calendar.

**Note**

Shows only if the real-time clock (calendar) kit is installed and the LAN interface is selected.

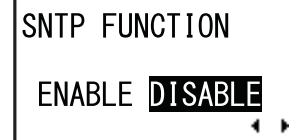
**IPv4/6 select**

Select IP address type of SNTP.

- **IPv4**
- **IPv6**

**Note**

Shows only if the SNTP function is enabled.

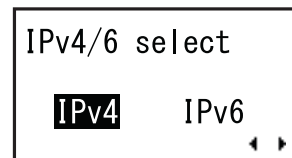
**NTP IPv4 ADDRESS**

Set the IPv4 address for NTP server.

The setting range is from 0.0.0.0 to 255.255.255.255.

**Note**

Shows only if the SNTP function is enabled.

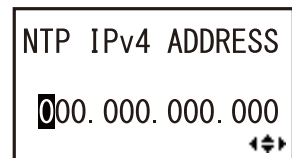

NTP IPv6 ADDRESS	
<p>Set the IPv6 address for NTP server.</p> <p>The setting range is from 0000:0000:0000:0000:0000:0000:0000 to FFFF:FFFF:FFFF:FFFF:FFFF:FFFF:FFFF:FFFF.</p> <hr/> <p><b>Note</b> Shows only if the SNTP function is enabled.</p> <hr/>	<div style="border: 1px solid black; padding: 5px; width: fit-content; margin: 0 auto;"> <p>NTP IPv6 ADDRESS</p> <p>0000:0000:0000: 0000:0000:0000: 0000:0000</p> <p style="text-align: right;">◀ ▶</p> </div>

TIME ZONE	
<p>Set the time zone.</p> <p>The setting range is from -12:45 to +14:45.</p> <hr/> <p><b>Note</b> Shows only if the SNTP function is enabled.</p> <hr/>	<div style="border: 1px solid black; padding: 5px; width: fit-content; margin: 0 auto;"> <p>TIME ZONE</p> <p>+00:00</p> <p style="text-align: right;">◀ ▶</p> </div>

ERROR NOTICE	
<p>Set whether or not to notify the SNTP function error.</p> <ul style="list-style-type: none"> <li>• <b>ENABLE</b>: Shows an error notice when failing to correct the time.</li> <li>• <b>DISABLE</b>: Does not show an error notice when failing to correct the time.</li> </ul> <hr/> <p><b>Note</b> Shows only if the SNTP function is enabled.</p> <hr/>	<div style="border: 1px solid black; padding: 5px; width: fit-content; margin: 0 auto;"> <p>ERROR NOTICE</p> <p>ENABLE <b>DISABLE</b></p> <p style="text-align: right;">◀ ▶</p> </div>

SNMP FUNCTION	
<p>Set the SNMP function.</p> <ul style="list-style-type: none"> <li>• <b>ENABLE</b>: Enables the SNMP function and goes to “SNMP setting select” screen.</li> <li>• <b>DISABLE</b>: Disables the SNMP function and goes to “Interface select screen.</li> </ul> <hr/> <p><b>Note</b> Shows only if the LAN interface is selected.</p> <hr/>	<div style="border: 1px solid black; padding: 5px; width: fit-content; margin: 0 auto;"> <p>SNMP FUNCTION</p> <p>ENABLE <b>DISABLE</b></p> <p style="text-align: right;">◀ ▶</p> </div>



### SNMP SET SELECT

Select SNMP settings.

- **SNMP SETTING**: Sets the SNMP settings. When selected, it goes to “SNMP setting” screen.
- **SNMP TRAP SET**: Selects the trap number of SNMP. When selected, it goes to “SNMP trap setting” screen.



### SNMP SETTING

Select community and authentication of SNMP.

- **SNMPv1/v2c [1]**: Goes to “Community name” screen.
- **SNMPv1/v2c [2]**: Goes to “Community name” screen.
- **SNMPv3 [1]**: Goes to “Authentication user name” screen.
- **SNMPv3 [2]**: Goes to “Authentication user name” screen.

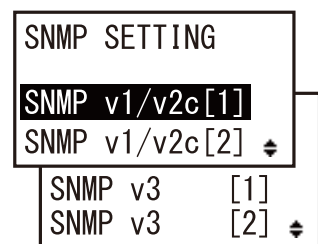

### SNMP TRAP SET

Select the trap number of SNMP from 1 to 3.

- **TRAP [1]**
- **TRAP [2]**
- **TRAP [3]**

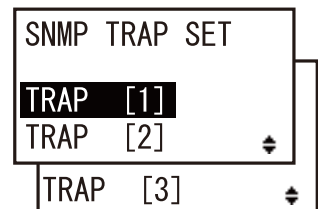

### TRAP TYPE SELECT

Select SNMP trap type.

- **SNMPv1**
- **SNMPv2c**
- **SNMPv3**

#### Note

The setting will be effective only if you power on the product again.

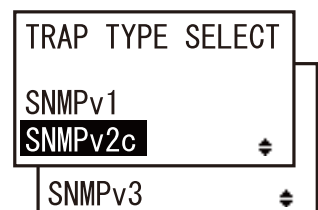

COMMUNITY NAME	
<p>Input SNMP community name.</p> <ul style="list-style-type: none"> <li>• When SNMPv1/v2c [1] is selected the default is “public”.</li> <li>• When SNMPv1/v2c [2] is selected the default is “ ” (none).</li> </ul> <hr/> <p><b>Note</b></p> <ul style="list-style-type: none"> <li>• Up to 32 alphanumeric characters and symbols (from 20H to 7EH) can be set.</li> <li>• Specify “_” to input a space.</li> <li>• The setting will be effective only if you power on the product again.</li> </ul>	

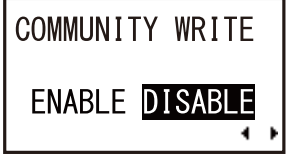
COMMUNITY WRITE	
<p>Enable or disable writing to MIB when accessing to community.</p> <ul style="list-style-type: none"> <li>• <b>ENABLE</b>: Allows writing to MIB.</li> <li>• <b>DISABLE</b>: Does not allow writing to MIB.</li> </ul> <hr/> <p><b>Note</b></p> <p>Writing possible OID are sysContact, sysName, and sysLocation.</p>	

USER NAME	
<p>Input SNMP authentication user name.</p> <p>Press the ◀/▶ buttons to shift the cursor and press the △/▽ buttons to change the value.</p> <p>Press the <b>ENTER</b> button to save the value and proceed to the next setting screen.</p> <hr/> <p><b>Note</b></p> <ul style="list-style-type: none"> <li>• Up to 32 alphanumeric characters and symbols (from 20H to 7EH) can be set.</li> <li>• Specify “_” to input a space.</li> <li>• The setting will be effective only if you power on the product again.</li> </ul>	

## AUTH PROTOCOL

Select SNMP authentication protocol.  
The options are as follows:

- **NONE**
- **MD5**
- **SHA-1**

### Note

The setting will be effective only if you power on the product again.

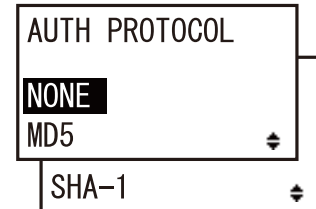

## AUTH KEY

Input SNMP authentication key.  
Input more than 8 characters for the authentication name.

Press the ◀/▶ buttons to shift the cursor and press the ▲/▼ buttons to change the value.

Press the **ENTER** button to save the value and proceed to the next setting screen.

### Note

- When the authentication name is less than 8 characters, there will be buzzer sounds and it will not move to the next screen.
- Up to 32 alphanumeric characters and symbols (from 20H to 7EH) can be set.
- Specify “\_” to input a space.
- The setting will be effective only if you power on the product again.



## PRIVACY PROTOCOL

Select SNMP privacy protocol.  
The options are as follows:

- **NONE**
- **DES**
- **AES**

### Note

The setting will be effective only if you power on the product again.

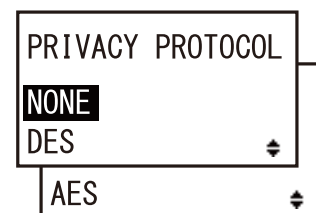

PRIVACY KEY	
<p>Input SNMP privacy key. Input more than 8 characters for the authentication name.</p> <p>Press the ◀/▶ buttons to shift the cursor and press the ▲/▼ buttons to change the value. Press the <b>ENTER</b> button to save the value and proceed to the next setting screen.</p> <hr/> <p><b>Note</b></p> <ul style="list-style-type: none"> <li>• When the authentication name is less than 8 characters, there will be buzzer sounds and it will not move to the next screen.</li> <li>• Up to 32 alphanumeric characters and symbols (from 20H to 7EH) can be set.</li> <li>• Specify “_” to input a space.</li> <li>• The setting will be effective only if you power on the product again.</li> </ul>	

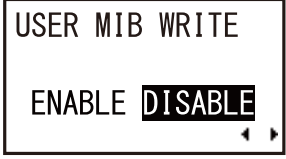
USER MIB WRITE	
<p>Enable or disable writing to MIB at authentication access.</p> <ul style="list-style-type: none"> <li>• <b>ENABLE</b>: Allows writing to MIB.</li> <li>• <b>DISABLE</b>: Does not allow writing to MIB.</li> </ul> <hr/> <p><b>Note</b></p> <p>Writing possible OID are sysContact, sysName, and sysLocation.</p>	

TRAP	
<p>Set the SNMP trap.</p> <ul style="list-style-type: none"> <li>• <b>ENABLE</b>: Allows the SNMP trap.</li> <li>• <b>DISABLE</b>: Does not allow the SNMP trap.</li> </ul> <hr/> <p><b>Note</b></p> <p>The setting will be effective only if you power on the product again.</p>	

**COMMUNITY NAME**

Input SNMP trap community name.

Press the ◀/▶ buttons to shift the cursor and press the △/▽ buttons to change the value.

Press the **ENTER** button to save the value and proceed to the next setting screen.

**Note**

- When the authentication name is less than 8 characters, there will be buzzer sounds and it will not move to the next screen.
- Up to 32 alphanumeric characters and symbols (from 20H to 7EH) can be set.
- Specify “\_” to input a space.
- The setting will be effective only if you power on the product again.

**USER NAME**

Input SNMP trap authentication user name.

Press the ◀/▶ buttons to shift the cursor and press the △/▽ buttons to change the value.

Press the **ENTER** button to save the value and proceed to the next setting screen.

**Note**

- Up to 32 alphanumeric characters and symbols (from 20H to 7EH) can be set.
- Specify “\_” to input a space.
- The setting will be effective only if you power on the product again.

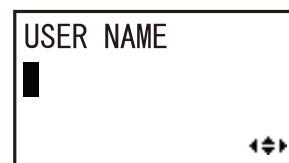
**AUTH PROTOCOL**

Select SNMP trap authentication protocol.

The options are as follows:

- **NONE**
- **MD5**
- **SHA-1**

**Note**

The setting will be effective only if you power on the product again.

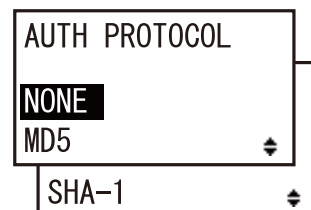

AUTH KEY	
<p>Input SNMP trap authentication key. Input more than 8 characters for the authentication name.</p> <p>Press the ◀/▶ buttons to shift the cursor and press the ▲/▼ buttons to change the value. Press the <b>ENTER</b> button to save the value and proceed to the next setting screen.</p> <hr/> <p><b>Note</b></p> <ul style="list-style-type: none"> <li>• When the authentication name is less than 8 characters, there will be buzzer sounds and it will not move to the next screen.</li> <li>• Up to 32 alphanumeric characters and symbols (from 20H to 7EH) can be set.</li> <li>• Specify “_” to input a space.</li> <li>• The setting will be effective only if you power on the product again.</li> </ul>	

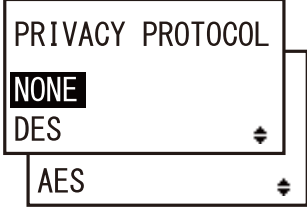
PRIVACY PROTOCOL	
<p>Select SNMP trap privacy protocol. The options are as follows:</p> <ul style="list-style-type: none"> <li>• <b>NONE</b></li> <li>• <b>DES</b></li> <li>• <b>AES</b></li> </ul> <hr/> <p><b>Note</b></p> <p>The setting will be effective only if you power on the product again.</p>	

PRIVACY KEY	
<p>Input SNMP trap privacy key. Input more than 8 characters for the authentication name.</p> <p>Press the ◀/▶ buttons to shift the cursor and press the ▲/▼ buttons to change the value. Press the <b>ENTER</b> button to save the value and proceed to the next setting screen.</p> <hr/> <p><b>Note</b></p> <ul style="list-style-type: none"> <li>• When the authentication name is less than 8 characters, there will be buzzer sounds and it will not move to the next screen.</li> <li>• Up to 32 alphanumeric characters and symbols (from 20H to 7EH) can be set.</li> <li>• Specify “_” to input a space.</li> <li>• The setting will be effective only if you power on the product again.</li> </ul>	

**TRAP IPv4 ADR**

Set the IPv4 address where trap is output.  
The setting range is from 0.0.0.0 to 255.255.255.255.

**Note**

Shows only if the SNTP function is enabled.

TRAP IPv4 ADR  
000.000.000.000

**TRAP IPv6 ADR**

Set the IPv6 address where trap is output.  
The setting range is from 0000:0000:0000:0000:0000:0000:0000:0000 to FFFF:FFFF:FFFF:FFFF:FFFF:FFFF:FFFF:FFFF.

**Note**

Shows only if the SNTP function is enabled.

TRAP IPv6 ADR  
0000:0000:0000:  
0000:0000:0000:  
0000:0000

**FINISH SETTING?**

Confirm to complete the setting.

- **YES:** Returns to the INTERFACE MODE menu screen.
- **NO:** Returns to the SNMP SET SELECT screen to select an item.

FINISH SETTING?  
YES **NO**

## USB Setting

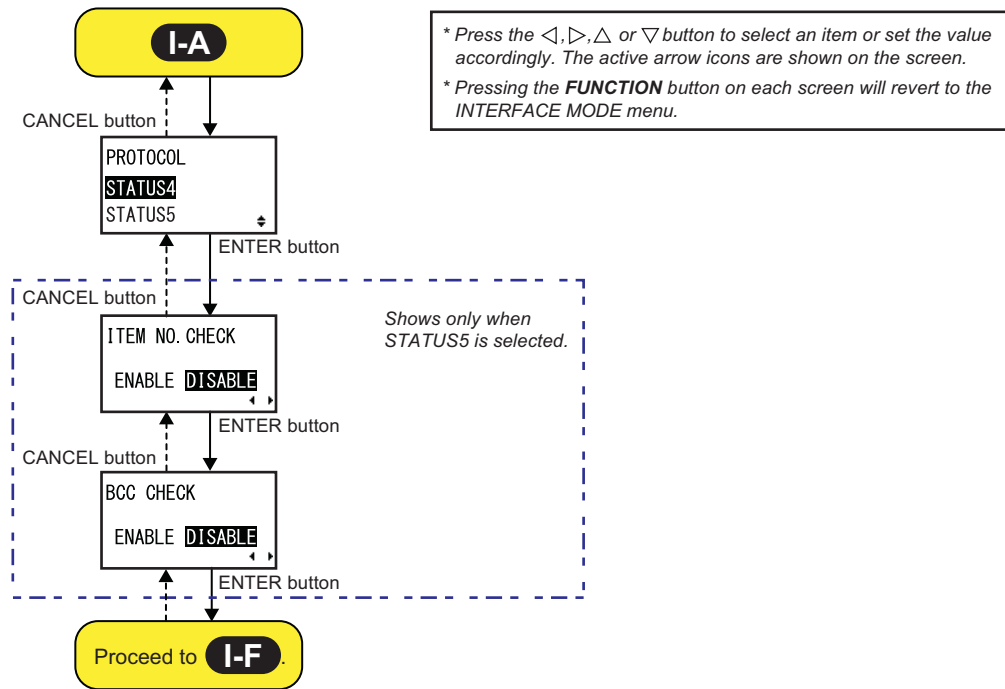

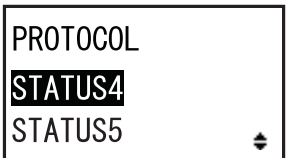
<b>PROTOCOL</b>	
Set the communication protocol. <ul style="list-style-type: none"> <li><b>STATUS4:</b> When selected, the product will proceed to the IGNORE CR/LF screen.</li> <li><b>STATUS5:</b> When selected, the product will proceed to the ITEM NO. CHECK screen.</li> </ul>	

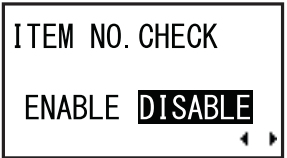
<b>ITEM NO. CHECK</b>	
Set the item number check function. <ul style="list-style-type: none"> <li><b>ENABLE:</b> Enable the item number check function.</li> <li><b>DISABLE:</b> Disable the item number check function.</li> </ul> <hr/> <p><b>Note</b> Shows only if PROTOCOL is set to STATUS5.</p> <hr/>	



<b>BCC CHECK</b>	
<p>Set the BCC check function.</p> <ul style="list-style-type: none"><li>• <b>ENABLE</b>: Enable the BCC check function.</li><li>• <b>DISABLE</b>: Disable the BCC check function.</li></ul> <hr/> <p><b>Note</b> Shows only if PROTOCOL is set to STATUS5.</p> <hr/>	 <p>The screenshot shows a menu titled "BCC CHECK" with two options: "ENABLE" and "DISABLE". The "DISABLE" option is highlighted with a black background and white text. There are left and right arrow keys at the bottom of the menu.</p>

## LAN Setting

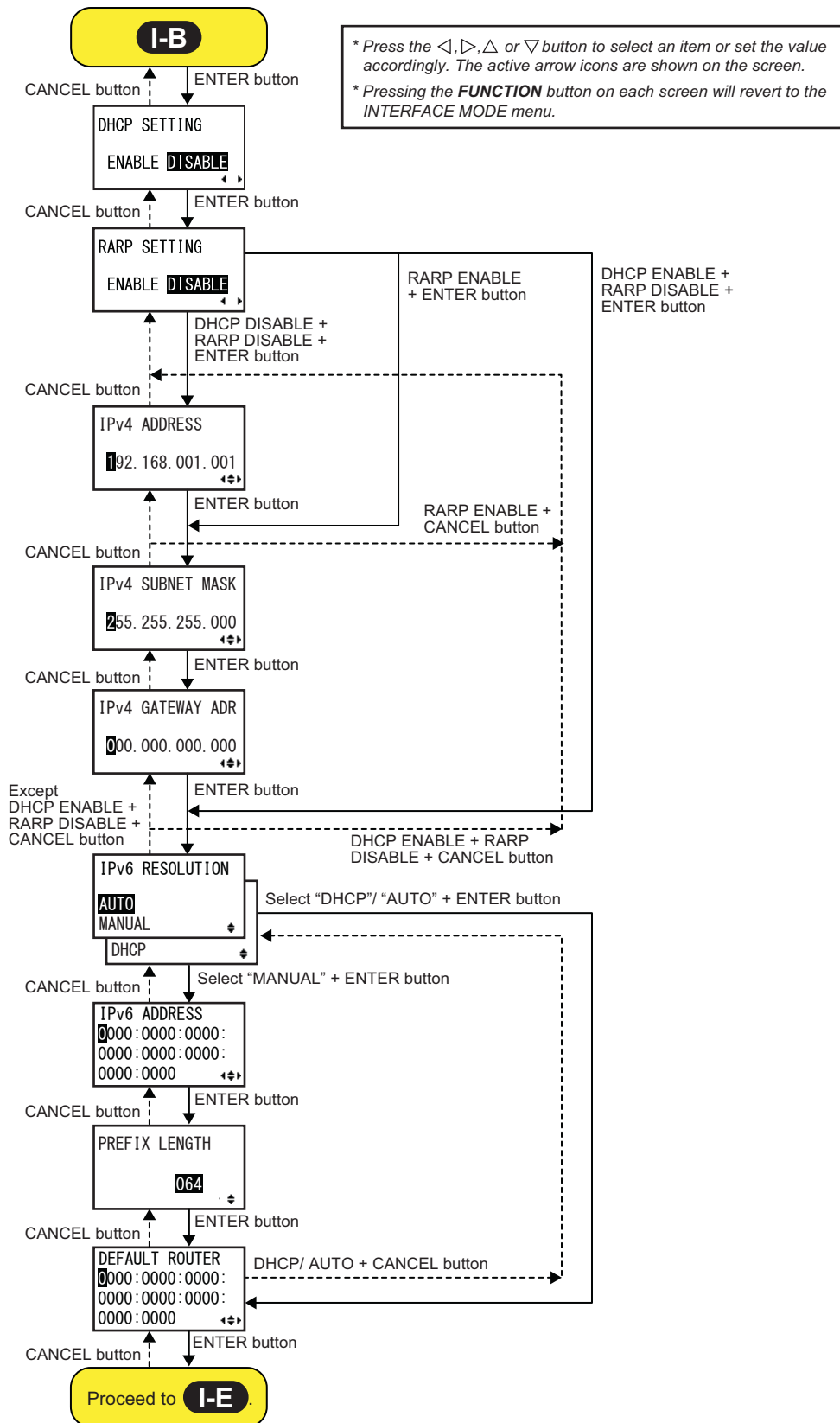

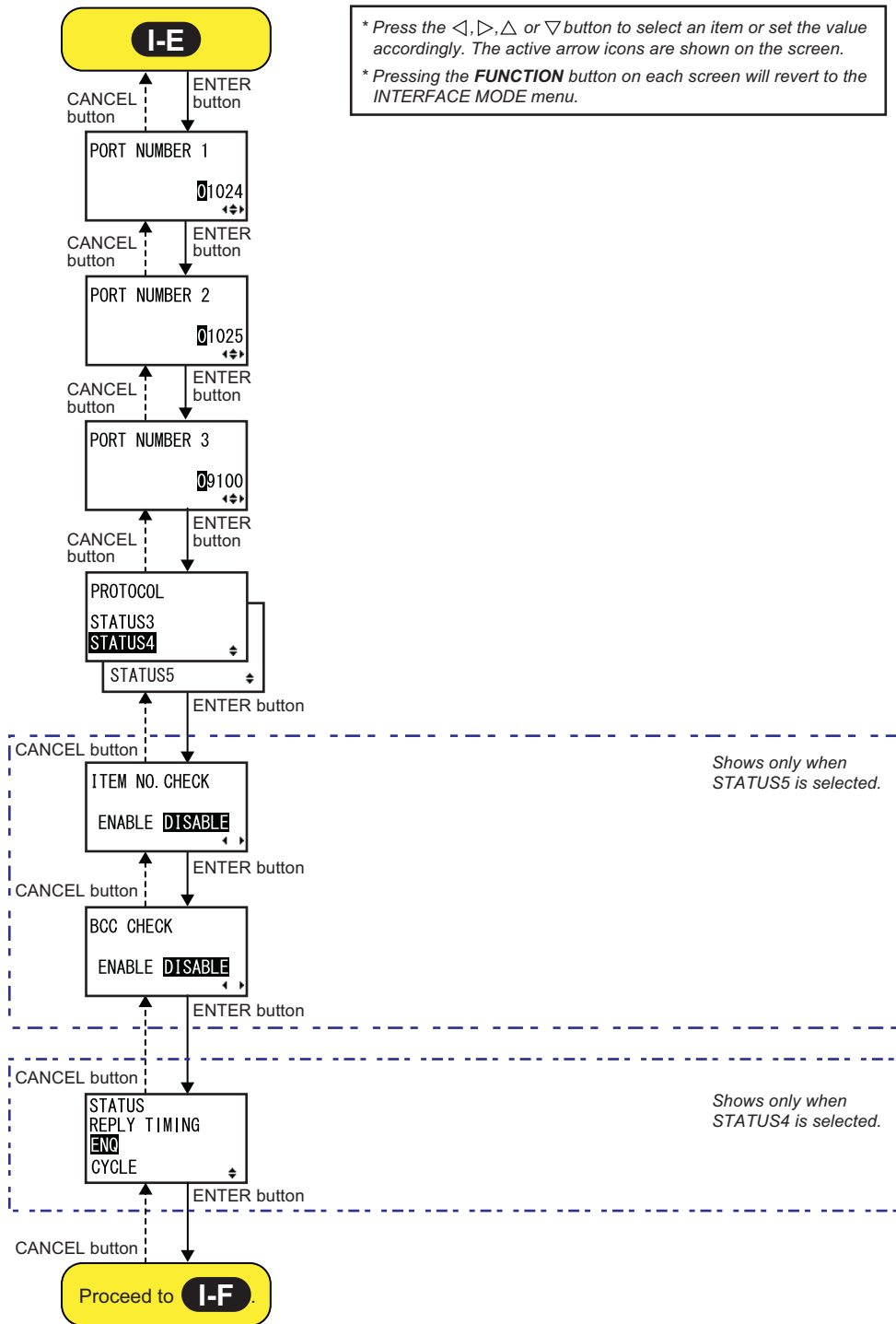

\* Press the ◀, ▶, ▲ or ▼ button to select an item or set the value accordingly. The active arrow icons are shown on the screen.  
 \* Pressing the **FUNCTION** button on each screen will revert to the **INTERFACE MODE** menu.

DHCP SETTING	
<p>Enable or disable DHCP.</p> <ul style="list-style-type: none"> <li>• <b>ENABLE:</b> Enable DHCP.</li> <li>• <b>DISABLE:</b> Disable DHCP.</li> </ul> <hr/> <p><b>Note</b></p> <ul style="list-style-type: none"> <li>• Shows only if the LAN interface is selected.</li> <li>• The setting will be effective only if you power on the product again.</li> </ul>	<div style="border: 1px solid black; padding: 5px; width: fit-content; margin: auto;"> <p>DHCP SETTING</p> <p>ENABLE <b>DISABLE</b> <span style="float: right;">◀ ▶</span></p> </div>

RARP SETTING	
<p>Enable or disable RARP.</p> <ul style="list-style-type: none"> <li>• <b>ENABLE:</b> Enable RARP.</li> <li>• <b>DISABLE:</b> Disable RARP.</li> </ul> <hr/> <p><b>Note</b></p> <ul style="list-style-type: none"> <li>• Shows only if the LAN interface is selected.</li> <li>• The setting will be effective only if you power on the product again.</li> </ul>	<div style="border: 1px solid black; padding: 5px; width: fit-content; margin: auto;"> <p>RARP SETTING</p> <p>ENABLE <b>DISABLE</b> <span style="float: right;">◀ ▶</span></p> </div>

IPv4 ADDRESS	
<p>Set the IPv4 address.</p> <p>The setting range is from 0.0.0.0 to 255.255.255.255.</p> <p>The default value is 192.168.001.001.</p> <hr/> <p><b>Note</b></p> <ul style="list-style-type: none"> <li>• Shows only if the LAN interface is selected.</li> <li>• The setting will be effective only if you power on the product again.</li> </ul>	<div style="border: 1px solid black; padding: 5px; width: fit-content; margin: auto;"> <p>IPv4 ADDRESS</p> <p><b>1</b>92.168.001.001 <span style="float: right;">◀ ▶</span></p> </div>

IPv4 SUBNET MASK	
<p>Set the IPv4 subnet mask address.</p> <p>The setting range is from 0.0.0.0 to 255.255.255.255.</p> <p>The default value is 255.255.255.000.</p> <hr/> <p><b>Note</b></p> <ul style="list-style-type: none"> <li>• Shows only if the LAN interface is selected.</li> <li>• The setting will be effective only if you power on the product again.</li> </ul>	<div style="border: 1px solid black; padding: 5px; width: fit-content; margin: auto;"> <p>IPv4 SUBNET MASK</p> <p><b>2</b>55.255.255.000 <span style="float: right;">◀ ▶</span></p> </div>

**IPv4 GATEWAY ADR**

Set the IPv4 gateway address.  
The setting range is from 0.0.0.0 to 255.255.255.255.  
The default value is 000.000.000.000 for LAN.

**Note**

- Shows only if the LAN interface is selected.
- The setting will be effective only if you power on the product again.

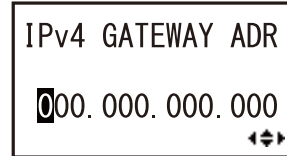
**IPv6 RESOLUTION**

Select IPv6 address setting method.  
The options are as follows:

- **AUTO**
- **MANUAL**
- **DHCP**

**Note**

- Shows only if the LAN interface is selected.
- The setting will be effective only if you power on the product again.

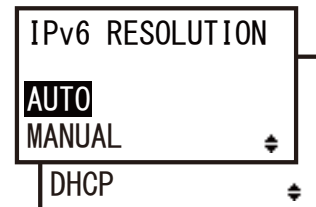
**IPv6 ADDRESS**

Set the IPv6 address.

**Note**

Shows only if the LAN interface is selected and "MANUAL" is selected at "IPv6 RESOLUTION" screen.

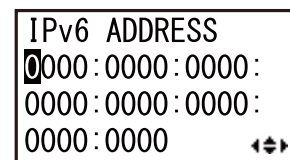
**PREFIX LENGTH**

Set the prefix length.  
The setting range is from 000 to 128.

**Note**

Shows only if the LAN interface is selected and "MANUAL" is selected at "IPv6 RESOLUTION" screen.



**DEFAULT ROUTER**

Set the default router of IPv6.

---

**Note**  
Shows only if the LAN interface is selected.

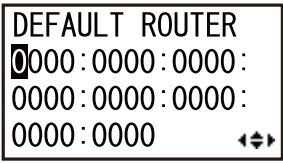

**PORT NUMBER**

Set the LAN port numbers, 1 to 3.  
The setting range is from 00001 to 65535.  
The setting details is as follows:

Port Number	Initial Value	Description	
		Status 3, 5	Status 4
1	1024	Bi-Directional Port	Input port
2	1025	Not applicable	Output port
3	9100	Bi-Directional Port	Bi-Directional Port

---

**Note**

- Shows only if the LAN interface is selected.
- Each port (1, 2 and 3) must be set to different values.
- When changing the port number, it is recommended to set to 1024 and above.
- The setting will be effective only if you power on the product again.

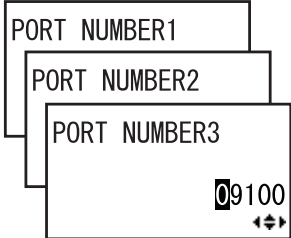



**PROTOCOL**

Set the communication protocol.

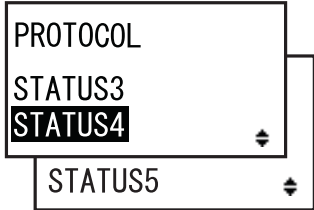
- STATUS3:** When selected, the product will proceed to the IGNORE CR/LF screen.
- STATUS4:** When selected, the product will proceed to the STATUS REPLY TIMING screen.
- STATUS5:** When selected, the product will proceed to the ITEM NO. CHECK screen.



ITEM NO. CHECK	
<p>Set the item number check function.</p> <ul style="list-style-type: none"> <li>• <b>ENABLE</b>: Enable the item number check function.</li> <li>• <b>DISABLE</b>: Disable the item number check function.</li> </ul> <hr/> <p><b>Note</b> Shows only if PROTOCOL is set to STATUS5.</p> <hr/>	 <p>The screenshot shows a menu titled 'ITEM NO. CHECK'. Below the title are two options: 'ENABLE' and 'DISABLE'. The 'DISABLE' option is highlighted with a black background. There are left and right arrow keys at the bottom right of the menu.</p>

BCC CHECK	
<p>Set the BCC check function.</p> <ul style="list-style-type: none"> <li>• <b>ENABLE</b>: Enable the BCC check function.</li> <li>• <b>DISABLE</b>: Disable the BCC check function.</li> </ul> <hr/> <p><b>Note</b> Shows only if PROTOCOL is set to STATUS5.</p> <hr/>	 <p>The screenshot shows a menu titled 'BCC CHECK'. Below the title are two options: 'ENABLE' and 'DISABLE'. The 'DISABLE' option is highlighted with a black background. There are left and right arrow keys at the bottom right of the menu.</p>

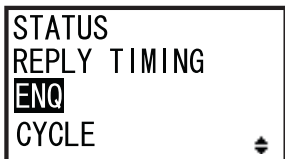
STATUS REPLY TIMING	
<p>Set the timing for replying with the status information to the host.</p> <ul style="list-style-type: none"> <li>• <b>ENQ</b>: Returns a status after receiving a Status Request (ENQ), which has been sent from the host.</li> <li>• <b>CYCLE</b>: Returns a status from the product to the host at an interval of 500ms.</li> </ul> <hr/> <p><b>Note</b> Shows only if PROTOCOL is set to STATUS4.</p> <hr/>	 <p>The screenshot shows a menu titled 'STATUS REPLY TIMING'. Below the title are two options: 'ENQ' and 'CYCLE'. The 'ENQ' option is highlighted with a black background. There are left and right arrow keys at the bottom right of the menu.</p>

## RS-232C Setting

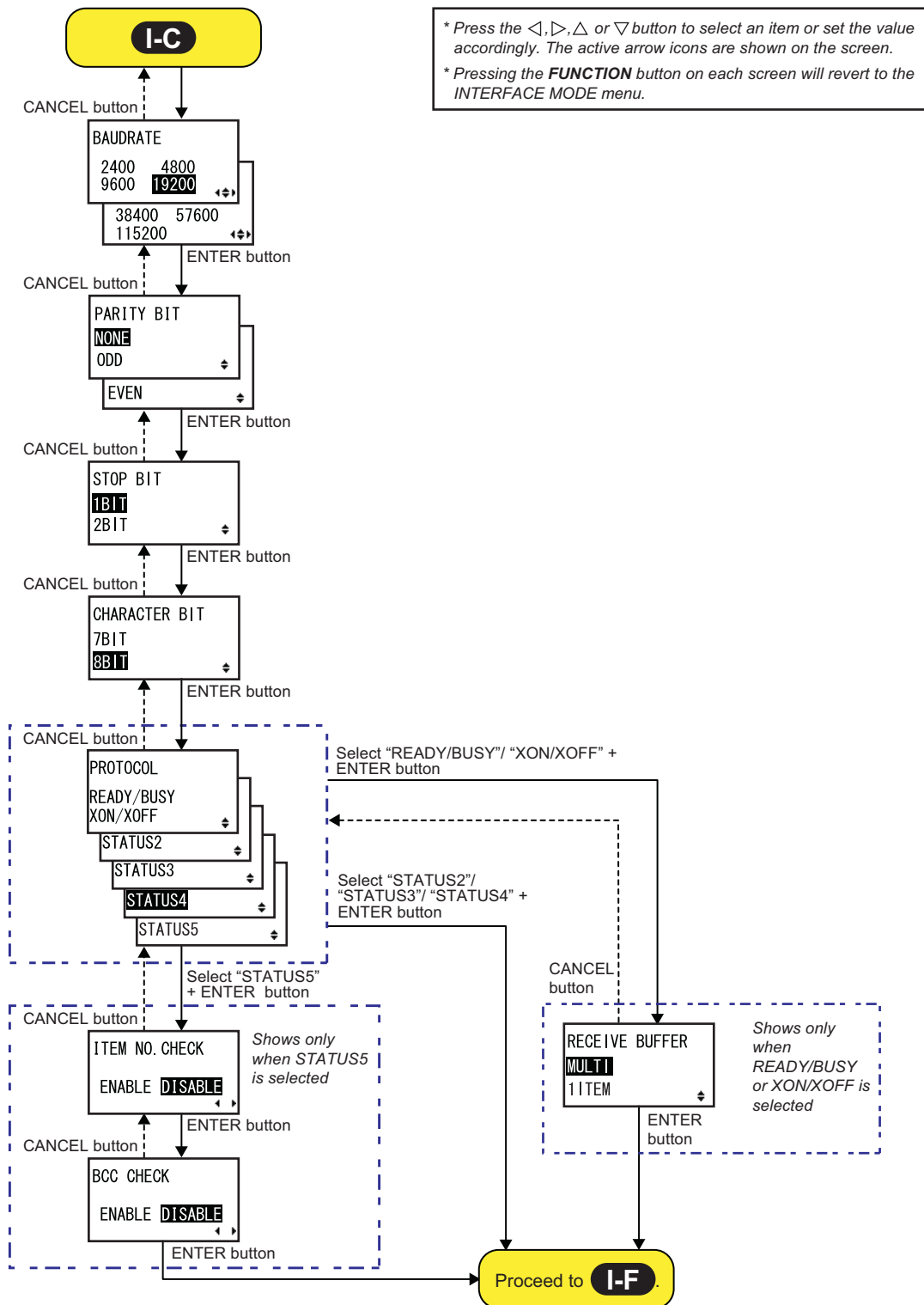



**BAUDRATE**

Set the RS-232C baudrate (bps).  
The following baudrates are available:

- 2400
- 4800
- 9600
- 19200
- 38400
- 57600
- 115200

**Note**

- Shows only if the RS-232C interface is selected.
- The setting will be effective only if you power on the product again.

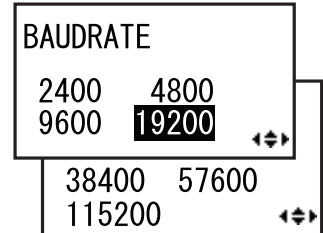
**PARITY BIT**

Set the RS-232C parity bit.  
The following options are available:

- NONE
- ODD
- EVEN

**Note**

- Shows only if the RS-232C interface is selected.
- The setting will be effective only if you power on the product again.

**STOP BIT**

Set the RS-232C stop bit.  
The following options are available:

- 1BIT
- 2BIT

**Note**

- Shows only if the RS-232C interface is selected.
- The setting will be effective only if you power on the product again.

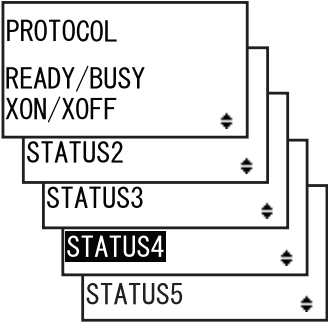

CHARACTER BIT	
<p>Set the RS-232C data length. The following options are available:</p> <ul style="list-style-type: none"> <li>• <b>7BIT</b></li> <li>• <b>8BIT</b></li> </ul> <hr/> <p><b>Note</b></p> <ul style="list-style-type: none"> <li>• Shows only if the RS-232C interface is selected.</li> <li>• The setting will be effective only if you power on the product again.</li> </ul>	 <p>A screenshot of the 'CHARACTER BIT' menu. The text 'CHARACTER BIT' is at the top. Below it, '7BIT' is listed, and '8BIT' is highlighted with a black background. A small double-headed arrow is at the bottom right of the menu box.</p>

PROTOCOL	
<p>Set the communication protocol.</p> <ul style="list-style-type: none"> <li>• <b>READY/BUSY</b>: When selected, the product will proceed to the RECEIVE BUFFER screen.</li> <li>• <b>XON/OFF</b>: When selected, the product will proceed to the RECEIVE BUFFER screen.</li> <li>• <b>STATUS2</b>: When selected, the product will proceed to the IGNORE CR/LF screen.</li> <li>• <b>STATUS3</b>: When selected, the product will proceed to the IGNORE CR/LF screen.</li> <li>• <b>STATUS4</b>: When selected, the product will proceed to the IGNORE CR/LF screen.</li> <li>• <b>STATUS5</b>: When selected, the product will proceed to the ITEM NO. CHECK screen.</li> </ul> <hr/> <p><b>Note</b></p> <p>The setting will be effective only if you power on the product again.</p>	 <p>A screenshot of the 'PROTOCOL' menu. The text 'PROTOCOL' is at the top. Below it, 'READY/BUSY', 'XON/XOFF', 'STATUS2', 'STATUS3', 'STATUS4', and 'STATUS5' are listed. 'STATUS4' is highlighted with a black background. Each menu item has a small double-headed arrow to its right.</p>

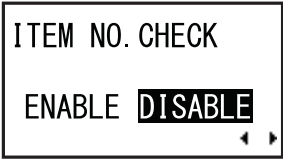
ITEM NO. CHECK	
<p>Set the item number check function.</p> <ul style="list-style-type: none"> <li>• <b>ENABLE</b>: Enable the item number check function.</li> <li>• <b>DISABLE</b>: Disable the item number check function.</li> </ul> <hr/> <p><b>Note</b></p> <p>Shows only if PROTOCOL is set to STATUS5.</p>	 <p>A screenshot of the 'ITEM NO. CHECK' menu. The text 'ITEM NO. CHECK' is at the top. Below it, 'ENABLE' and 'DISABLE' are listed. 'DISABLE' is highlighted with a black background. A small double-headed arrow is at the bottom right of the menu box.</p>

**BCC CHECK**

Set the BCC check function.

- **ENABLE**: Enable the BCC check function.
- **DISABLE**: Disable the BCC check function.

**Note**

Shows only if PROTOCOL is set to STATUS5.

**RECEIVE BUFFER**

Set the receive buffer type.

- **MULTI**: Multiple receive buffers.
- **1ITEM**: A single receive buffer.

**Note**

Shows only if PROTOCOL is set to READY/BUSY or XON/XOFF.



## IEEE1284 Setting

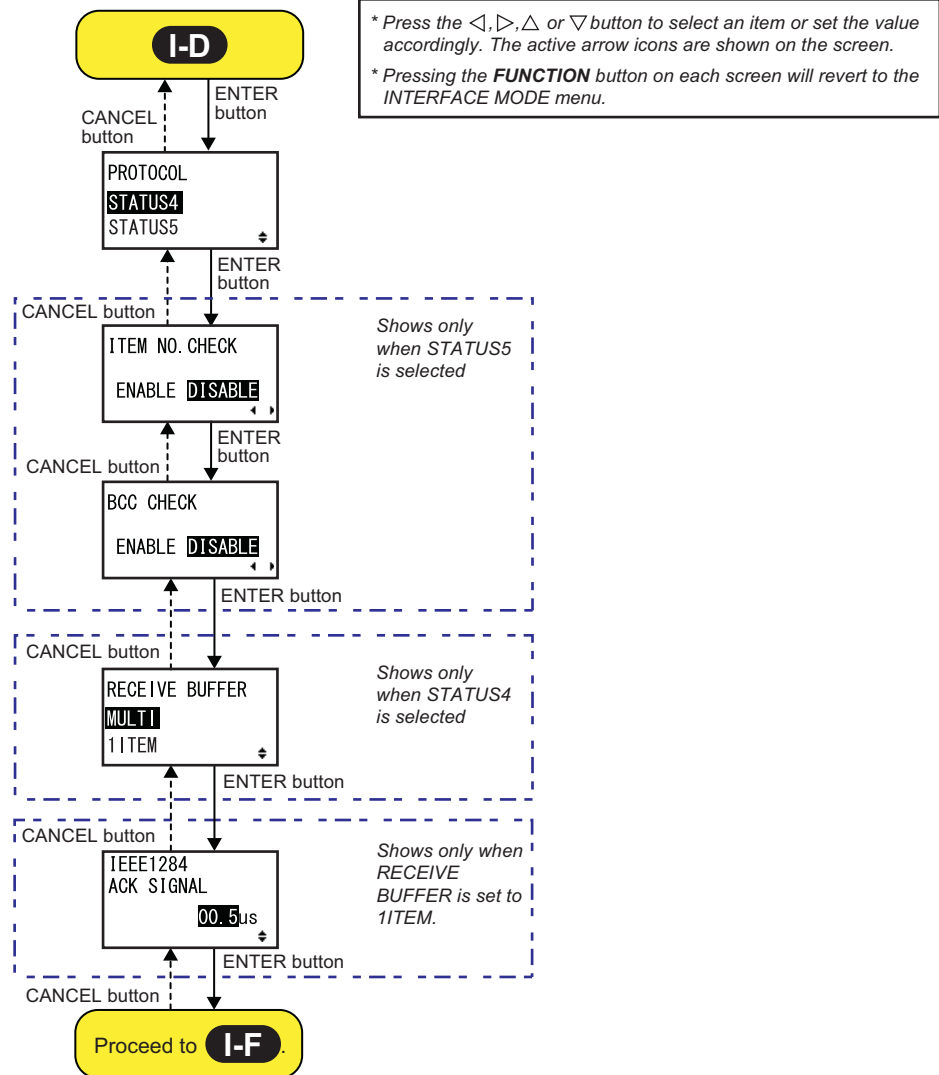

**PROTOCOL**

Set the communication protocol.

- **STATUS4**: When selected, the product will proceed to the RECEIVE BUFFER screen.
- **STATUS5**: When selected, the product will proceed to the ITEM NO. CHECK screen.

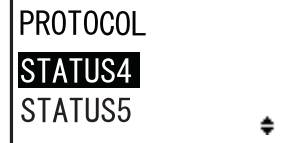
**ITEM NO. CHECK**

Set the item number check function.

- **ENABLE**: Enable the item number check function.
- **DISABLE**: Disable the item number check function.

**Note**

Shows only if PROTOCOL is set to STATUS5.

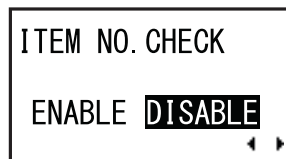
**BCC CHECK**

Set the BCC check function.

- **ENABLE**: Enable the BCC check function.
- **DISABLE**: Disable the BCC check function.

**Note**

Shows only if PROTOCOL is set to STATUS5.

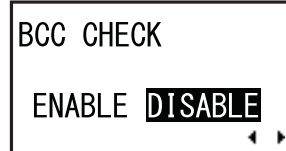
**RECEIVE BUFFER**

Set the receive buffer type.

- **MULTI**: Multiple receive buffers.
- **1ITEM**: A single receive buffer.

**Note**

Shows only if PROTOCOL is set to STATUS4.

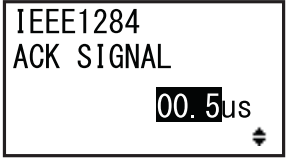

<b>IEEE1284 ACK SIGNAL</b>	
<p>Set the width of the IEEE1284 ACK signal. The setting range is from 00.5 <math>\mu</math>s to 12.0 <math>\mu</math>s, and is adjustable in 0.1 <math>\mu</math>s steps.</p> <hr/> <p><b>Note</b> Shows only if the IEEE1284 interface is selected and RECEIVE BUFFER is set to 1ITEM.</p> <hr/>	 <p>The screenshot shows a rectangular menu box with the text "IEEE1284 ACK SIGNAL" at the top. Below this text, the value "00.5us" is displayed in a larger font, with a small up/down arrow icon to its right, indicating it is a selectable value.</p>

## 4.2.7 Memory Mode

The flowchart shows the sequence of the setting screens for the memory mode. The table describes each setting screen in detail.

### CAUTION

Be sure to perform a virus check on the USB memory or SD card before connecting it to the product. SATO Corporation shall not be held responsible for any product malfunctions caused by a virus spread via USB memory or SD card.

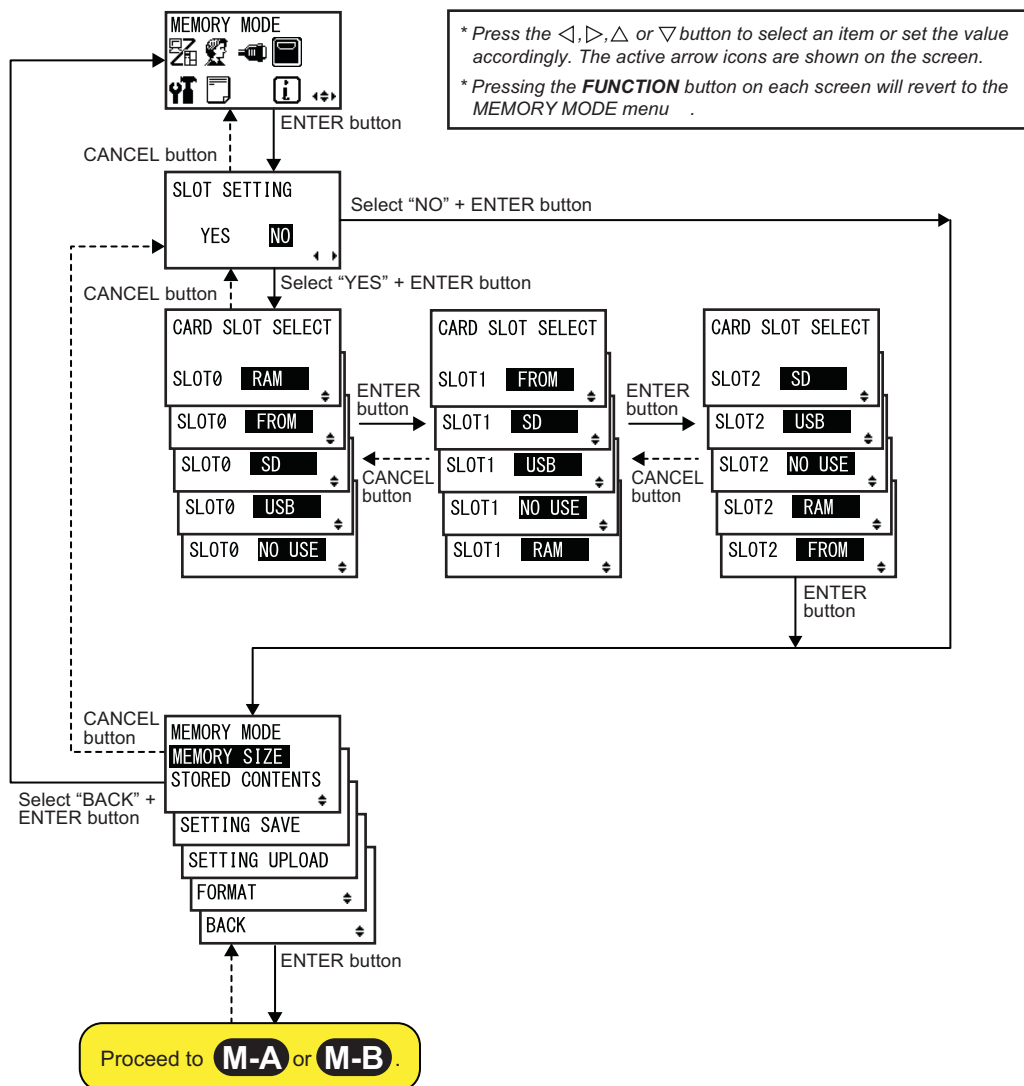

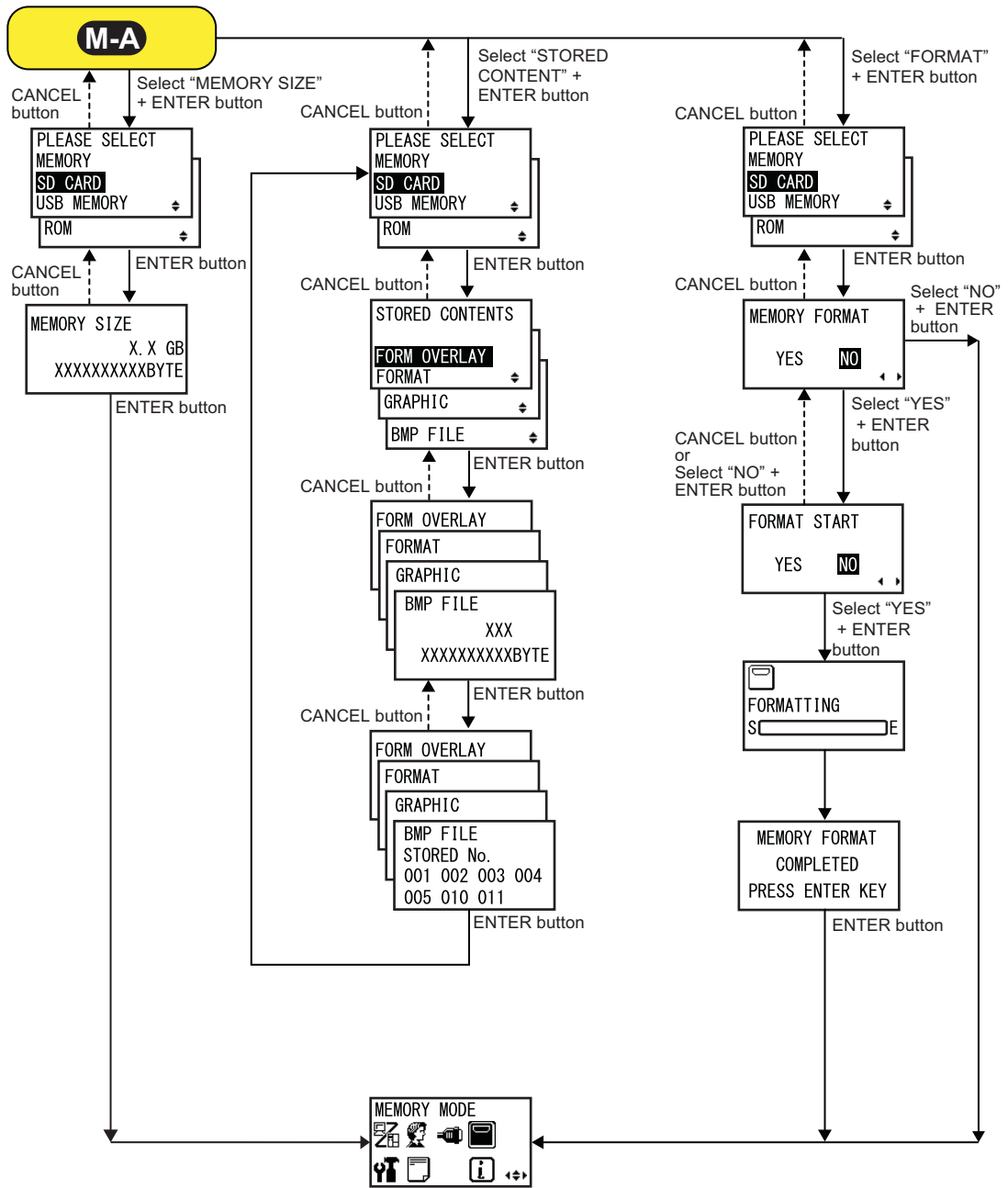



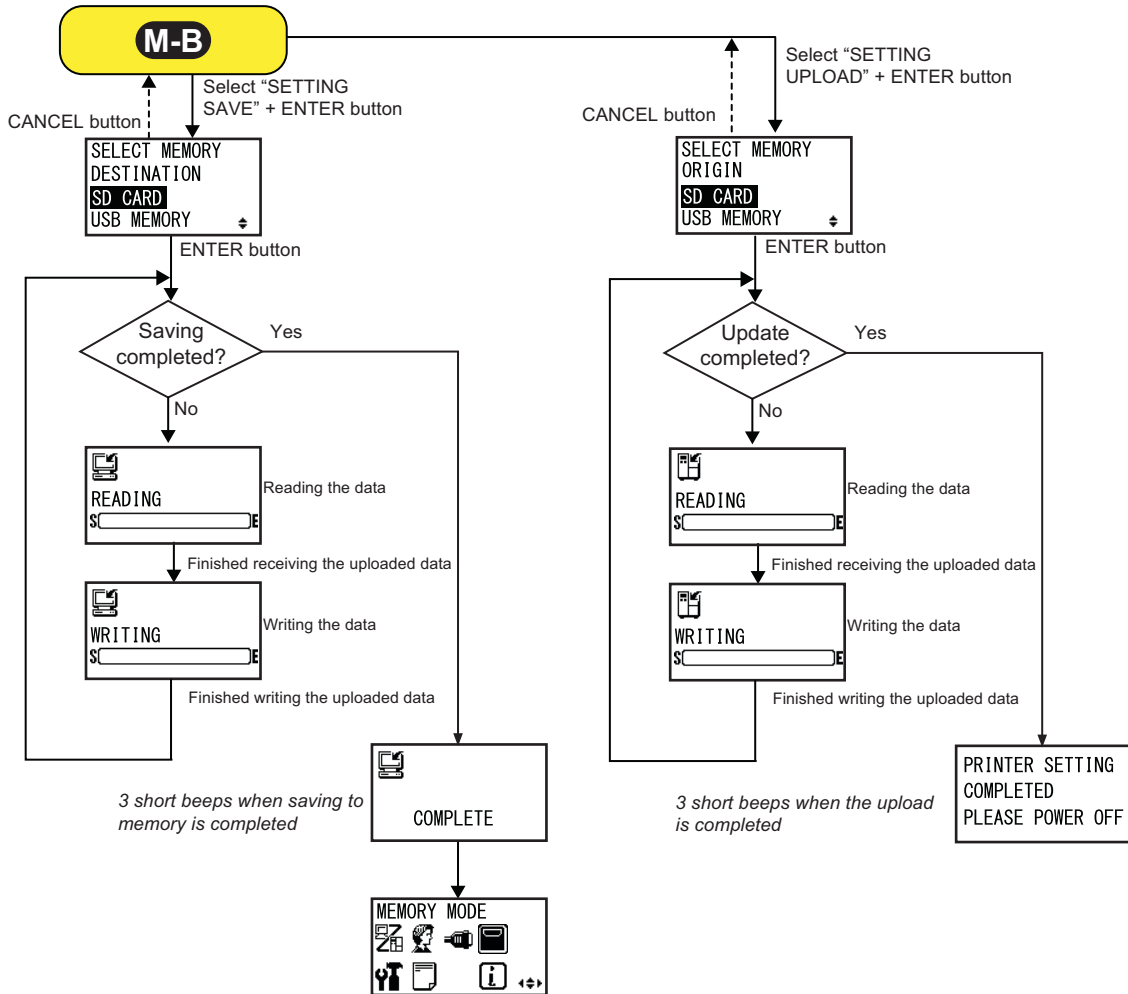

SLOT SETTING	
<p>Select whether or not to set the memory storage allocation for use with the Memory card command &lt;CC&gt;.</p> <ul style="list-style-type: none"> <li>• <b>YES</b>: Proceed to change the storage allocation for the memory slot.</li> <li>• <b>NO</b>: No change to the memory slot.</li> </ul> <hr/> <p><b>Note</b> Refer to the Programming reference for details on the command.</p> <hr/>	<div style="border: 1px solid black; padding: 10px; width: fit-content; margin: 0 auto;"> <p>SLOT SETTING</p> <p>YES    <b>NO</b>    ◀ ▶</p> </div>

CARD SLOT SELECT	
<p>Set the memory storage allocation for each card slot for use with the Memory card command &lt;CC&gt;. A total of three slots can be set (Slot 0-2). Each card slot can be allocated to the following options:</p> <ul style="list-style-type: none"> <li>• <b>RAM</b></li> <li>• <b>FROM</b> (Flash ROM)</li> <li>• <b>SD</b> (SD card)</li> <li>• <b>USB</b> (USB memory)</li> <li>• <b>NO USE</b></li> </ul> <hr/> <p><b>Note</b></p> <ul style="list-style-type: none"> <li>• Other than the NO USE option, a memory storage allocated to a card slot cannot be allocated to another card slot.</li> <li>• Refer to the Programming reference for details on the command.</li> </ul>	

MEMORY MODE	
<p>Select the memory operation. The following options are available:</p> <ul style="list-style-type: none"> <li>• <b>MEMORY SIZE</b>: Check the free size of the selected memory.</li> <li>• <b>STORED CONTENTS</b>: Shows the information that is registered in the selected memory.</li> <li>• <b>SETTING SAVE</b>: Save the setting information of the product to the selected memory.</li> <li>• <b>SETTING UPLOAD</b>: Update the setting information stored in the selected memory.</li> <li>• <b>FORMAT</b>: Initialize and format the selected memory.</li> <li>• <b>BACK</b>: Returns to the MEMORY MODE screen.</li> </ul>	

PLEASE SELECT MEMORY	
<p>Select the memory you want to perform the settings. The following options are available:</p> <ul style="list-style-type: none"> <li>• <b>SD CARD</b></li> <li>• <b>USB MEMORY</b></li> <li>• <b>ROM</b></li> </ul> <hr/> <p><b>Note</b></p> <p>Shows only if MEMORY MODE is set to MEMORY SIZE, STORED CONTENTS or FORMAT.</p>	

MEMORY SIZE	
<p>Check the free size of the selected memory.                      The memory unit (BYTE, KB, MB, GB) changes automatically according to the free space of the memory.                      KB: more than 1024 bytes                      MB: more than 1,048,576 bytes                      GB: more than 1,073,741,824 bytes</p> <hr/> <p><b>Note</b>                      After you press the <b>ENTER</b> button, the screen returns to MEMORY MODE.</p>	<div style="border: 1px solid black; padding: 10px; width: fit-content; margin: auto;"> <p>MEMORY SIZE</p> <p style="margin-left: 100px;">X. X GB</p> <p>XXXXXXXXXXBYTE</p> </div>

STORED CONTENTS	
<p>Select the type of information registered in the memory.                      The following options are available:</p> <ul style="list-style-type: none"> <li>• <b>FORM OVERLAY</b></li> <li>• <b>FORMAT</b></li> <li>• <b>GRAPHIC</b></li> <li>• <b>BMP FILE</b></li> </ul>	<div style="border: 1px solid black; padding: 10px; width: fit-content; margin: auto;"> <p>STORED CONTENTS</p> <div style="border: 1px solid black; padding: 2px; margin-bottom: 2px;"> <p><b>FORM OVERLAY</b></p> </div> <div style="border: 1px solid black; padding: 2px; margin-bottom: 2px;"> <p>FORMAT</p> </div> <div style="border: 1px solid black; padding: 2px; margin-bottom: 2px;"> <p>GRAPHIC</p> </div> <div style="border: 1px solid black; padding: 2px;"> <p>BMP FILE</p> </div> </div>

MEMORY INFORMATION	
<p>Shows the number of files and total size of the selected type of information registered in the memory.</p> <p>The maximum number of files is 999.</p>	<div style="border: 1px solid black; padding: 10px; width: fit-content; margin: auto;"> <div style="border: 1px solid black; padding: 2px; margin-bottom: 2px;"> <p>FORM OVERLAY</p> </div> <div style="border: 1px solid black; padding: 2px; margin-bottom: 2px;"> <p>FORMAT</p> </div> <div style="border: 1px solid black; padding: 2px; margin-bottom: 2px;"> <p>GRAPHIC</p> </div> <div style="border: 1px solid black; padding: 2px;"> <p>BMP FILE</p> <p style="text-align: center;">XXX</p> <p>XXXXXXXXXXBYTE</p> </div> </div>

STORED NO. INFORMATION	
<p>Shows the stored number of the registered information.</p> <p>The stored number range is from 001 to 999.</p> <hr/> <p><b>Note</b> After you press the <b>ENTER</b> button, the screen returns to PLEASE SELECT MEMORY.</p> <hr/>	

MEMORY FORMAT	
<p>Select whether or not to format the memory.</p> <ul style="list-style-type: none"> <li>• <b>YES</b>: Format the memory.</li> <li>• <b>NO</b>: Do not format the memory.</li> </ul>	

FORMAT START	
<p>Confirm to start formatting the memory.</p> <ul style="list-style-type: none"> <li>• <b>YES</b>: Start to format the memory.</li> <li>• <b>NO</b>: Cancel formatting the memory.</li> </ul> <hr/> <p><b>Note</b> If you select NO, the screen returns to MEMORY FORMAT.</p> <hr/>	

FORMATTING	
<p>Shows the formatting progress of the memory.</p> <hr/> <p><b>Note</b> After formatting the memory card, a completion message will show.</p> <hr/>	

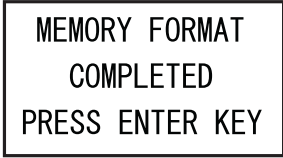
<b>MEMORY FORMAT COMPLETED</b>	
Shows that the formatting of the memory card is completed.	
<p><b>Note</b> After you press the <b>ENTER</b> button, the screen returns to MEMORY MODE.</p>	

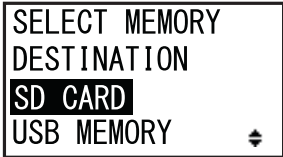
<b>SELECT MEMORY DESTINATION</b>	
<p>Select the memory to save the setting information of the product. The following options are available:</p> <ul style="list-style-type: none"> <li>• <b>SD CARD</b></li> <li>• <b>USB MEMORY</b></li> </ul>	
<p><b>Note</b> Shows only if MEMORY MODE is set to SETTING SAVE.</p>	

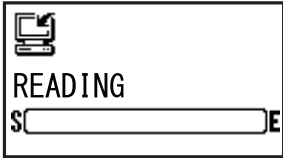
<b>READING (SETTING SAVE)</b>	
Shows while the product is reading the setting information data.	
<p><b>Note</b> Automatically shows the WRITING screen upon completion.</p>	

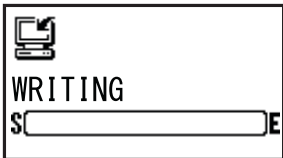
<b>WRITING (SETTING SAVE)</b>	
Shows while the product is writing the setting information data.	
<p><b>Note</b> Shows the COMPLETE screen automatically upon completion.</p>	

<b>COMPLETE</b>	
Shows when the setting information of the product has been saved to memory.	
<p><b>Note</b> After three beeps, the screen returns to MEMORY MODE.</p>	

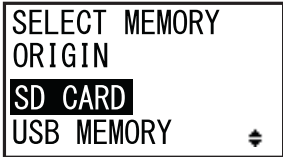
<b>SELECT MEMORY ORIGIN</b>	
<p>Select the memory to copy the setting information. The following options are available:</p> <ul style="list-style-type: none"> <li>• <b>SD CARD</b></li> <li>• <b>USB MEMORY</b></li> </ul>	
<p><b>Note</b> Shows only if MEMORY MODE is set to SETTING UPLOAD.</p>	

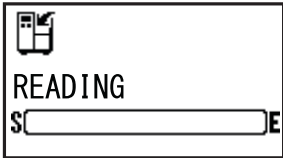
<b>READING (SETTING UPLOAD)</b>	
Shows while the product is reading the setting information data.	
<p><b>Note</b> Automatically shows the WRITING screen upon completion.</p>	

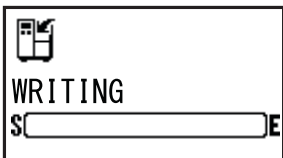
<b>WRITING (SETTING UPLOAD)</b>	
Shows while the product is writing the setting information data.	
<p><b>Note</b> Automatically shows the PRINTER SETTING COMPLETED screen upon completion.</p>	

<b>PRINTER SETTING COMPLETED</b>	
Shows when the setting information has been uploaded to the product.	<div style="border: 1px solid black; padding: 5px; text-align: center;">PRINTER SETTING COMPLETED PLEASE POWER OFF</div>
<p><b>Note</b></p> <ul style="list-style-type: none"><li>• Three beeps will sound when the upload is completed.</li><li>• The setting will be effective only if you power on the product again.</li></ul>	

## 4.2.8 Advanced Mode

The advanced mode lets you configure the more advanced features of the product hardware. The flowchart shows the sequence of the setting screens for the advanced mode. The table describes each setting screen in detail.

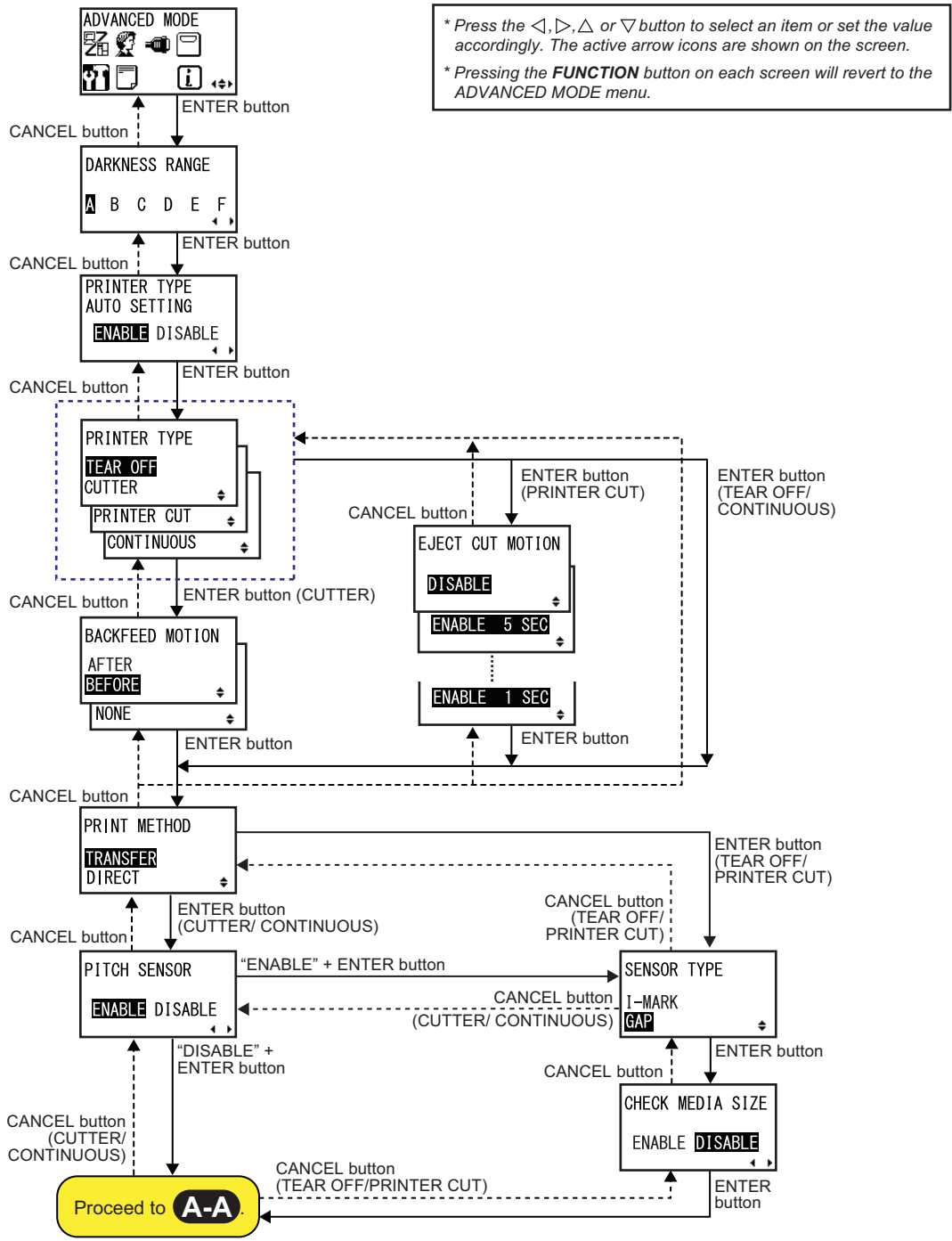



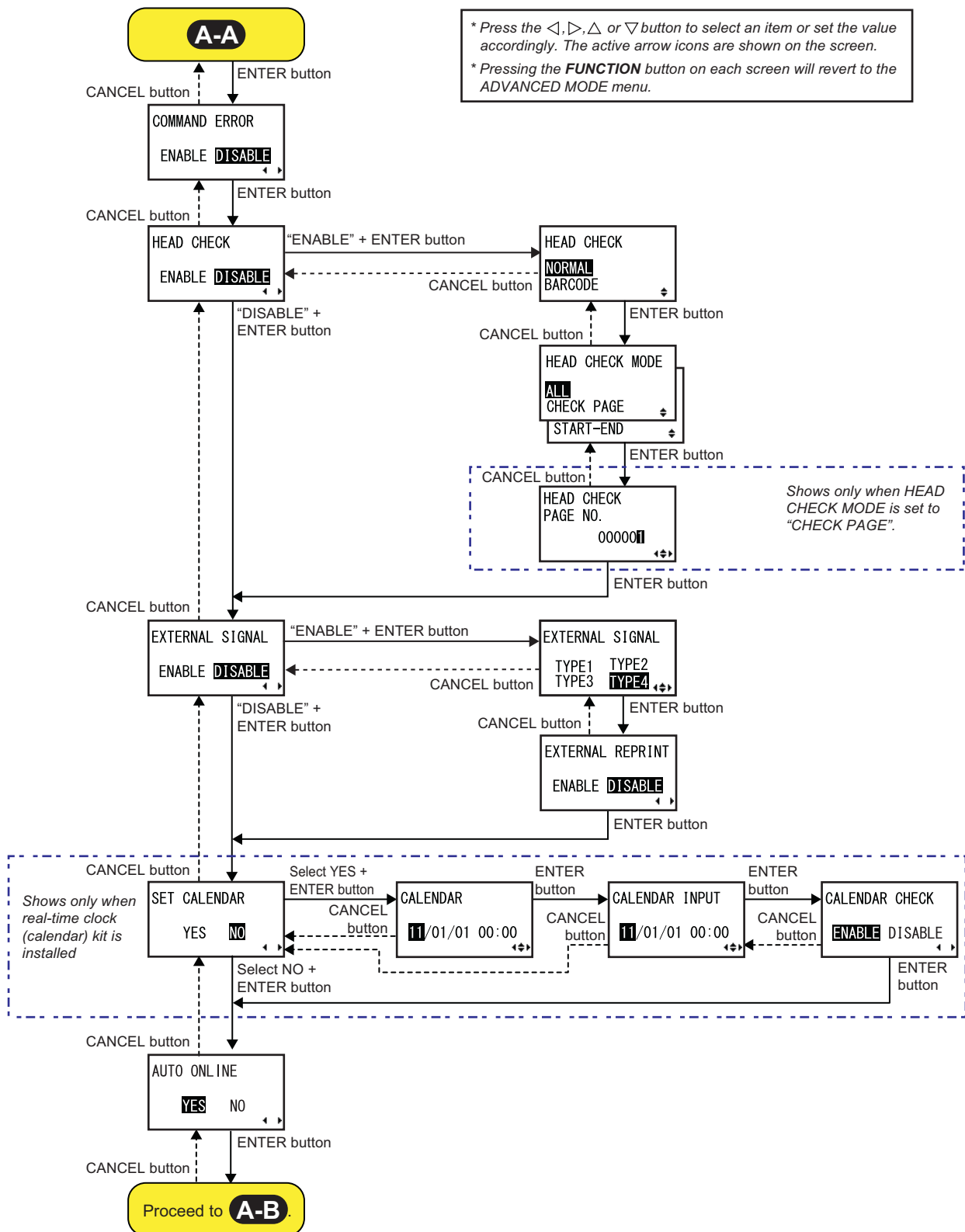

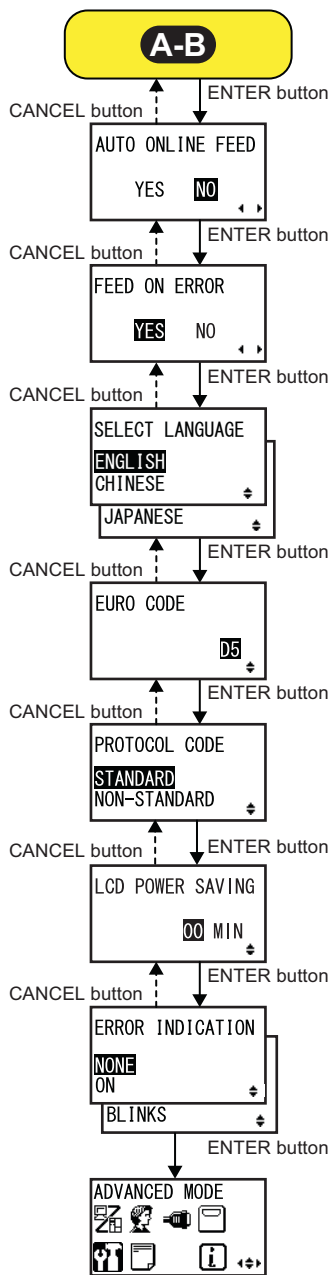

\* Press the ◀, ▶, ▲ or ▼ button to select an item or set the value accordingly. The active arrow icons are shown on the screen.  
 \* Pressing the **FUNCTION** button on each screen will revert to the **ADVANCED MODE** menu.

DARKNESS RANGE	
<p>Set the print darkness.                      Available options displayed on the screen are from A to F. But “B to F” are reserved. If selecting “B to F”, the buzzer will sound and unable to proceed.</p>	

### PRINTER TYPE AUTO SETTING

Enable or disable the switching of the operation mode by auto detection of the cutter unit.

If ENABLE is selected, and the cutter unit is installed, CUTTER will be automatically selected on the PRINTER TYPE screen.

Select DISABLE to use other print mode other than CUTTER when cutter unit is installed.

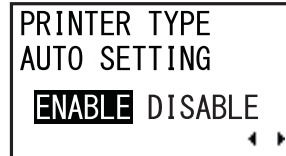

### PRINTER TYPE

Set the operation mode.

- **TEAR OFF:** After continuously printing the specified number of the media, feed the media to the point to remove the media. After printing, tear off the media manually. The media will be back to the print head position for starting the next printing.
- **CUTTER:** Cut each media while printing the specified number of media. You can specify this option if you have installed the cutter unit.
- **PRINTER CUT:** Allows you to continuously print and cut at the specified media repeat. If no print data is received within the period specified for [Eject Cut], the product will feed the media to the cut position and cut the last printed media. You can specify this option if you have installed the cutter unit.
- **CONTINUOUS:** Continuously print the specified number of media. The media remains in position for printing at all times.

#### Note

If cutter unit is not installed, only TEAR OFF and CONTINUOUS are available.

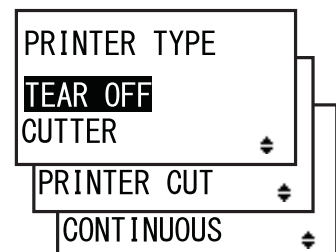

### BACKFEED MOTION

Backfeed is applicable only if the print mode is set to cutter mode.

- **AFTER:** After cut, backfeed the front part of the next media to the print head position.
- **BEFORE:** Before printing, backfeed the front part of the media to the print head position.
- **NONE:** Do not backfeed.

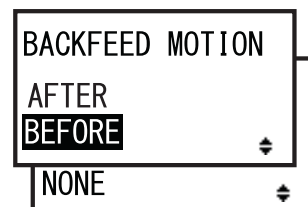



EJECT CUT MOTION	
<p>Set the Eject cut motion for the last printed media.</p> <ul style="list-style-type: none"> <li>• <b>DISABLE</b>: The Eject cut motion is set to off.</li> <li>• <b>ENABLE 5 SEC - 1 SEC</b>: The last printed media will be ejected and cut after the set timing. The timing can be set in the range from 5 seconds to 1 second cyclically.</li> </ul> <hr/> <p><b>Note</b> Shows only if PRINTER TYPE is set to PRINTER CUT.</p>	

PRINT METHOD	
<p>Set the print method.</p> <ul style="list-style-type: none"> <li>• <b>TRANSFER</b>: Print using a ribbon.</li> <li>• <b>DIRECT</b>: Print using direct thermal paper.</li> </ul>	

PITCH SENSOR	
<p>Enable or disable the pitch sensor.</p> <ul style="list-style-type: none"> <li>• <b>ENABLE</b>: Enable the pitch sensor.</li> <li>• <b>DISABLE</b>: Disable the pitch sensor.</li> </ul> <hr/> <p><b>Note</b> Shows only if PRINTER TYPE is set to CUTTER or CONTINUOUS.</p>	

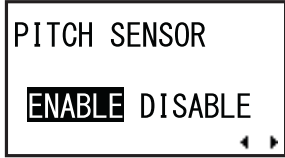
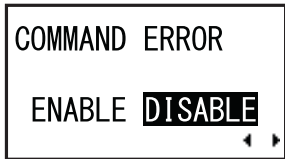
SENSOR TYPE	
<p>Set the type of sensor for sensing the media.</p> <ul style="list-style-type: none"> <li>• <b>I-MARK</b>: Use the reflective type sensor.</li> <li>• <b>GAP</b>: Use the transmissive type sensor.</li> </ul>	

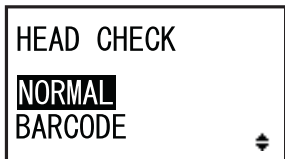
CHECK MEDIA SIZE	
<p>Enable or disable the function to check media size.</p> <ul style="list-style-type: none"> <li>• <b>ENABLE</b>: The function to check media size is on.</li> <li>• <b>DISABLE</b>: The function to check media size is off.</li> </ul> <hr/> <p><b>Note</b> Shows only if PITCH SENSOR is set to ENABLE.</p>	 <p>A screenshot of a menu titled "PITCH SENSOR". Below the title, the word "ENABLE" is highlighted with a black background, and "DISABLE" is to its right. At the bottom right of the menu, there are left and right arrow icons.</p>
COMMAND ERROR	
<p>Enable or disable the command error indication. This setting determines the product motion when detecting a command error.</p> <ul style="list-style-type: none"> <li>• <b>ENABLE</b>: Stops printing when a command error occurs.</li> <li>• <b>DISABLE</b>: Shows a warning icon and continues printing when a command error occurs.</li> </ul>	 <p>A screenshot of a menu titled "COMMAND ERROR". Below the title, the word "DISABLE" is highlighted with a black background, and "ENABLE" is to its left. At the bottom right of the menu, there are left and right arrow icons.</p>
HEAD CHECK	
<p>This product can be set to check the print head when printing each media.</p> <ul style="list-style-type: none"> <li>• <b>ENABLE</b>: Enable the head check function.</li> <li>• <b>DISABLE</b>: Disable the head check function.</li> </ul>	 <p>A screenshot of a menu titled "HEAD CHECK". Below the title, the word "DISABLE" is highlighted with a black background, and "ENABLE" is to its left. At the bottom right of the menu, there are left and right arrow icons.</p>
HEAD CHECK	
<p>Automatically check if there is a filament disconnection of the print head.</p> <ul style="list-style-type: none"> <li>• <b>NORMAL</b>: Check the entire print area.</li> <li>• <b>BARCODE</b>: Check only the area for printing a barcode. Head check is not applicable for barcodes printed as graphic data.</li> </ul> <hr/> <p><b>CAUTION</b> Head check is a reference for checking for a filament disconnection of the print head. This function does not guarantee barcode readability.</p> <hr/> <p><b>Note</b> Shows only if HEAD CHECK is set to ENABLE.</p>	 <p>A screenshot of a menu titled "HEAD CHECK". Below the title, the word "NORMAL" is highlighted with a black background, and "BARCODE" is below it. At the bottom right of the menu, there is a double-headed vertical arrow icon.</p>

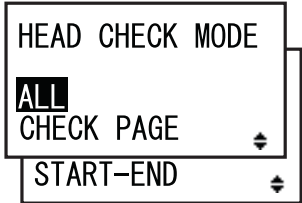
HEAD CHECK MODE	
<p>Set the method for the head check.</p> <ul style="list-style-type: none"> <li>• <b>ALL</b>: Perform the head check for every item.</li> <li>• <b>CHECK PAGE</b>: Perform the head check for each specified number of media.</li> <li>• <b>START-END</b>: The head check occurs before starting to print and when printing is stopped. If backfeed is applicable, the head check occurs before starting to print, when stopping to print and during the backfeed.</li> </ul> <hr/> <p><b>Note</b> Shows only if the head check function is enabled.</p>	 <p>A screenshot of a menu titled 'HEAD CHECK MODE'. It lists three options: 'ALL', 'CHECK PAGE', and 'START-END'. The 'ALL' option is highlighted with a black background. There are small up and down arrow icons to the right of 'CHECK PAGE' and 'START-END'.</p>

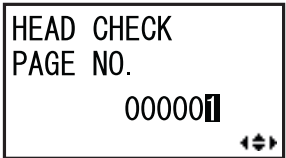
HEAD CHECK PAGE NO.	
<p>Specify the number of media between each head check. The setting range is from 000001 to 999999.</p> <hr/> <p><b>Note</b> Shows only if HEAD CHECK MODE is set to CHECK PAGE.</p>	 <p>A screenshot of a menu titled 'HEAD CHECK PAGE NO.'. It shows the value '000001' with a vertical bar to its right. There are small left and right arrow icons at the bottom right of the menu.</p>

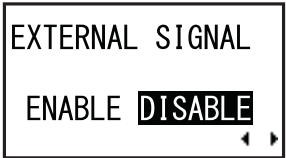
EXTERNAL SIGNAL	
<p>Enable or disable the external signal (EXT) function. If the external signal (EXT) function is enabled, data can be sent and received using an appropriate device plugged into the EXT connector.</p> <ul style="list-style-type: none"> <li>• <b>ENABLE</b>: Enable the external signal (EXT) function.</li> <li>• <b>DISABLE</b>: Disable the external signal (EXT) function.</li> </ul>	 <p>A screenshot of a menu titled 'EXTERNAL SIGNAL'. It lists two options: 'ENABLE' and 'DISABLE'. The 'DISABLE' option is highlighted with a black background. There are small left and right arrow icons at the bottom right of the menu.</p>

**EXTERNAL SIGNAL**

Set the output signal type of the print end signal (PREND).  
The following options are available:

Type	Operation Details
TYPE1	The print end signal (PREND) is High before label printing, and it becomes Low after print completion. The signal level becomes High after 20 ms.
TYPE2	The print end signal (PREND) is Low before label printing, and it becomes High after print completion. The signal level becomes Low after 20 ms.
TYPE3	The print end signal (PREND) is High before label printing, becomes Low from the start to the end of print, and becomes High again after print completion.
TYPE4	The print end signal (PREND) is Low before label printing, becomes High from the start to the end of print, and becomes Low again after print completion.

**Note**

- Shows only if EXTERNAL SIGNAL is set to ENABLE.
- Refer to the [Timing Chart of the EXT Input Signal](#) for details.

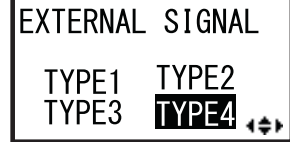
**EXTERNAL REPRINT**

Set the reprint function by reprint signal (PRIN2) from the external signal (Pin 7).

- **ENABLE:** Enable the reprint when no print quantity is remaining.
- **DISABLE:** Disable the reprint.

**Note**

The product will not reprint if a command error occurs.

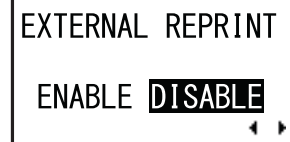
**SET CALENDAR**

Select whether or not to set the calendar.

- **YES:** Proceed to the calendar setting screen.
- **NO:** Proceed to the AUTO ONLINE screen.

**Note**

Shows only if the real-time clock (calendar) kit is installed.

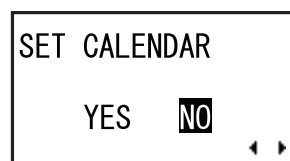

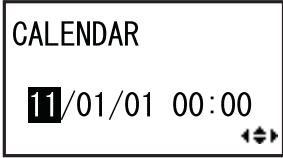
CALENDAR	
<p>Set the Year/Month/Date and then set the time in 24 hour format. The setting range is from 81/01/01 (January 01, 1981) to 80/12/31 (December 31, 2080). And the setting range for time is from 00:00 to 23:59.</p> <hr/> <p><b>Note</b> Shows only if YES is selected in the SET CALENDAR screen.</p>	

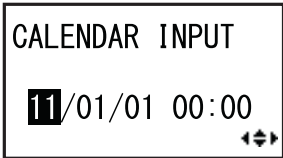
CALENDAR INPUT	
<p>This is the second input screen to confirm calendar setting. When the entered value of both screens match, it goes to the next screen after saving the value. If not, the product beeps and goes back to the first entry display.</p> <hr/> <p><b>Note</b> Shows only if YES is selected in the SET CALENDAR screen.</p>	

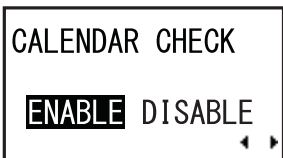
CALENDAR CHECK	
<p>Enable or disable the calendar check function.</p> <ul style="list-style-type: none"> <li>• <b>ENABLE</b>: Enable the calendar check function.</li> <li>• <b>DISABLE</b>: Disable the calendar check function.</li> </ul> <hr/> <p><b>Note</b> Shows only if YES is selected in the SET CALENDAR screen.</p>	

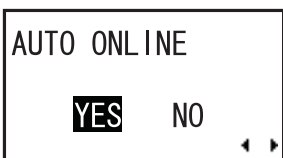
AUTO ONLINE	
<p>Set the auto online function. This function sets the product status at power on.</p> <ul style="list-style-type: none"> <li>• <b>YES</b>: Start up the product in online mode.</li> <li>• <b>NO</b>: Start up the product in offline mode.</li> </ul>	



**AUTO ONLINE FEED**

Set the auto online feed function.  
This function enables the product to automatically feed media in online mode after power on.

- **YES:** Feed the media in online mode at power on.
- **NO:** Do not feed the media in online mode at power on. However, if FEED ON ERROR is set to YES, the product feeds the media when it is powered on and changes to online mode.

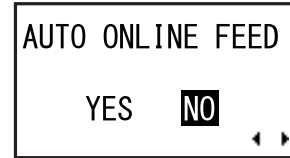
**FEED ON ERROR**

Set whether to automatically feed the media when recovering from an error and changing to online mode.

- **YES:** Feed the media when changing to online mode after recovering from an error.
- **NO:** Do not feed the media when changing to online mode after recovering from an error. However, if AUTO ONLINE FEED is set to YES, the product feeds the media when it is powered on and changes to online mode.

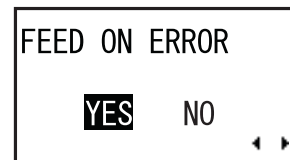
**SELECT LANGUAGE**

Set the LCD language.  
The following languages are available:

- **ENGLISH**
- **CHINESE** (Simplified Chinese)
- **JAPANESE**

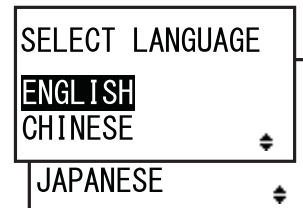
**EURO CODE**

Set the European currency symbol to a hex code.  
The setting range is from 00 to FF (hexadecimal).

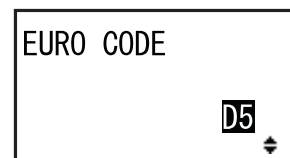

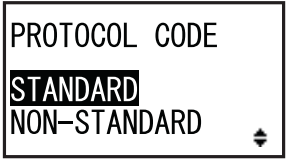
PROTOCOL CODE	
<p>Set the protocol code.</p> <ul style="list-style-type: none"> <li>• <b>STANDARD</b>: Use a standard code.</li> <li>• <b>NON-STANDARD</b>: Use a non-standard code.</li> </ul> <hr/> <p><b>Note</b> To set the non-standard code, send the user download command &lt;LD&gt; in normal mode. For more details on the &lt;LD&gt; command, refer to the Programming Reference.</p>	 <p>The image shows an LCD screen with the text 'PROTOCOL CODE' at the top. Below it, 'STANDARD' is highlighted with a black background, and 'NON-STANDARD' is listed below it. A small arrow icon is at the bottom right of the screen.</p>

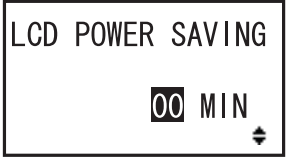
LCD POWER SAVING	
<p>Specify a period of time to light off the LCD backlight when the product is not operated. The setting range is from 00 to 15 minutes.</p> <hr/> <p><b>Note</b> This function is disabled if set to 00; the LCD backlight will remain on. For details, refer to <a href="#">Section 5.3 LCD Power Saving Mode</a>.</p>	 <p>The image shows an LCD screen with the text 'LCD POWER SAVING' at the top. Below it, '00 MIN' is highlighted with a black background. A small arrow icon is at the bottom right of the screen.</p>

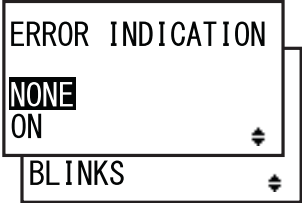
ERROR INDICATION	
<p>Set the LCD backlight for indicating an error.</p> <ul style="list-style-type: none"> <li>• <b>NONE</b>: No change to the LCD backlight.</li> <li>• <b>ON</b>: The LCD backlight lights orange.</li> <li>• <b>BLINKS</b>: The LCD backlight flashes orange.</li> </ul>	 <p>The image shows an LCD screen with the text 'ERROR INDICATION' at the top. Below it, 'NONE' is highlighted with a black background, and 'ON' is listed below it. A small arrow icon is at the bottom right of the screen. Below the main screen area, 'BLINKS' is also visible with a small arrow icon.</p>

### 4.2.9 Hex Dump Mode

The hex dump mode allows you to print the contents of the receive buffer in a hexadecimal format to allow the data stream to be examined for errors and troubleshooting. The flowchart shows the sequence of the setting screens for the hex dump mode. The table describes each setting screen in detail.

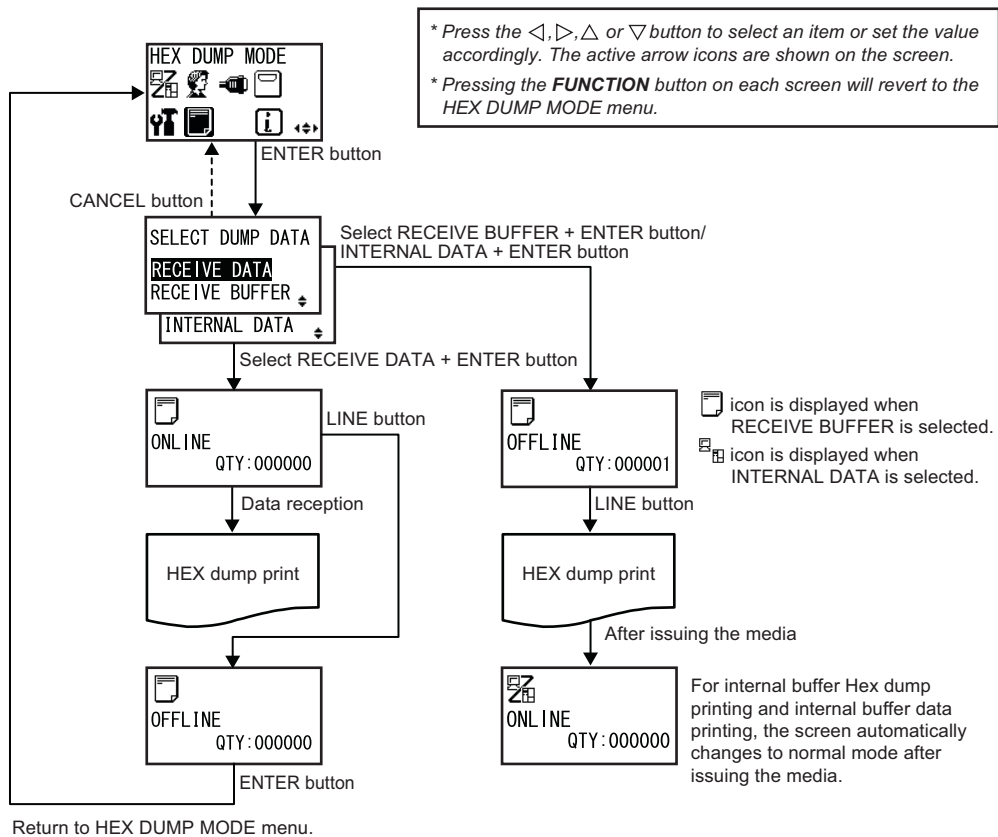

SELECT DUMP DATA	
<p>Select the data for printing the hex dump.</p> <ul style="list-style-type: none"> <li>• <b>RECEIVE DATA</b>: Print the hex dump of the received data.</li> <li>• <b>RECEIVE BUFFER</b>: Print the hex dump of the received print data (one item).</li> <li>• <b>INTERNAL DATA</b>: Print the setting values of the internal buffer.</li> </ul> <p><b>Note</b> RECEIVE BUFFER cannot be selected if there is no received data.</p>	

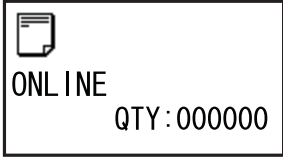
<b>ONLINE</b>	
<p>This screen shows an online status icon if RECEIVE DATA is selected.</p>	

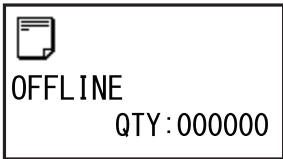
<b>OFFLINE</b>	
<p>This screen shows an offline status icon if RECEIVE DATA or RECEIVE BUFFER is selected.</p>	

### 4.2.10 Information Mode

The flowchart shows the sequence of the setting screens for the information mode. The table describes each setting screen in detail.

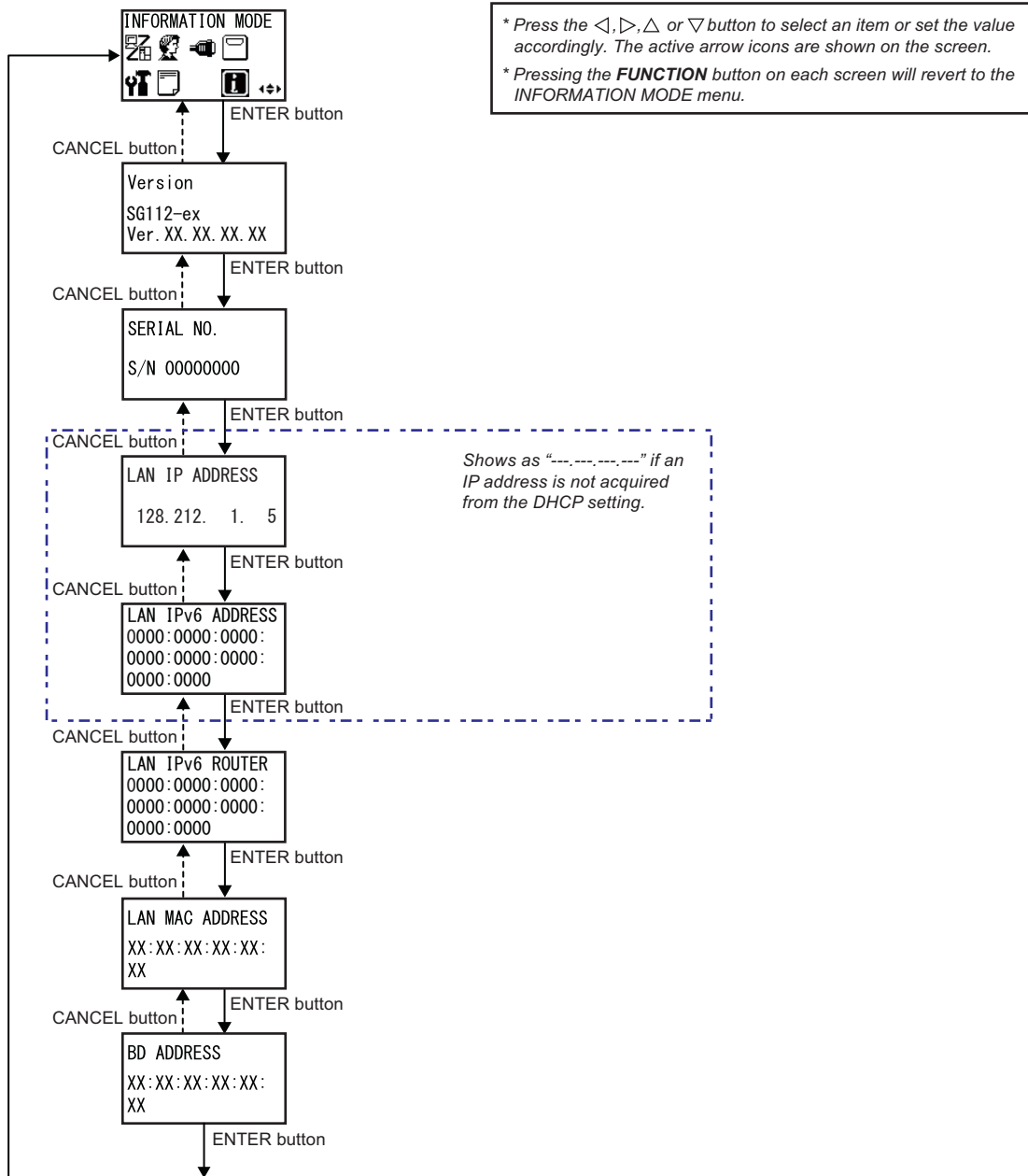

<b>Version</b>	
Shows the model name and firmware version of this product.	Version SG112-ex Ver. XX. XX. XX. XX

<b>SERIAL NO.</b>	
Shows the serial number of the control board in this product.	SERIAL NO. S/N 00000000

<b>LAN IPv4 ADDRESS</b>	
Shows the IPv4 address of the LAN.	LAN IP ADDRESS 128. 212. 1. 5
<hr/> <p><b>Note</b>                      If the IP address is not acquired from DHCP, it will be shown as "-----".</p>	

<b>LAN IPv6 ADDRESS</b>	
Shows the IPv6 address of the LAN.	LAN IPv6 ADDRESS 0000:0000:0000: 0000:0000:0000: 0000:0000
<hr/> <p><b>Note</b>                      If the IP address is not acquired from DHCP, it will be shown as "-----:-----:-----:-----:-----".</p>	

<b>LAN IPv6 ROUTER</b>	
Shows the IPv6 router information for the LAN.	LAN IPv6 ROUTER 0000:0000:0000: 0000:0000:0000: 0000:0000

<b>LAN MAC ADDRESS</b>		
Shows the MAC address of the LAN.	<table border="1"><tr><td>LAN MAC ADDRESS XX:XX:XX:XX:XX: XX</td></tr></table>	LAN MAC ADDRESS XX:XX:XX:XX:XX: XX
LAN MAC ADDRESS XX:XX:XX:XX:XX: XX		

<b>BD ADDRESS</b>		
Shows the BD address.	<table border="1"><tr><td>BD ADDRESS XX:XX:XX:XX:XX: XX</td></tr></table>	BD ADDRESS XX:XX:XX:XX:XX: XX
BD ADDRESS XX:XX:XX:XX:XX: XX		

### 4.2.11 Test Print Mode

The flowchart shows the sequence of the setting screens for the test print mode. The table describes each setting screen in detail.

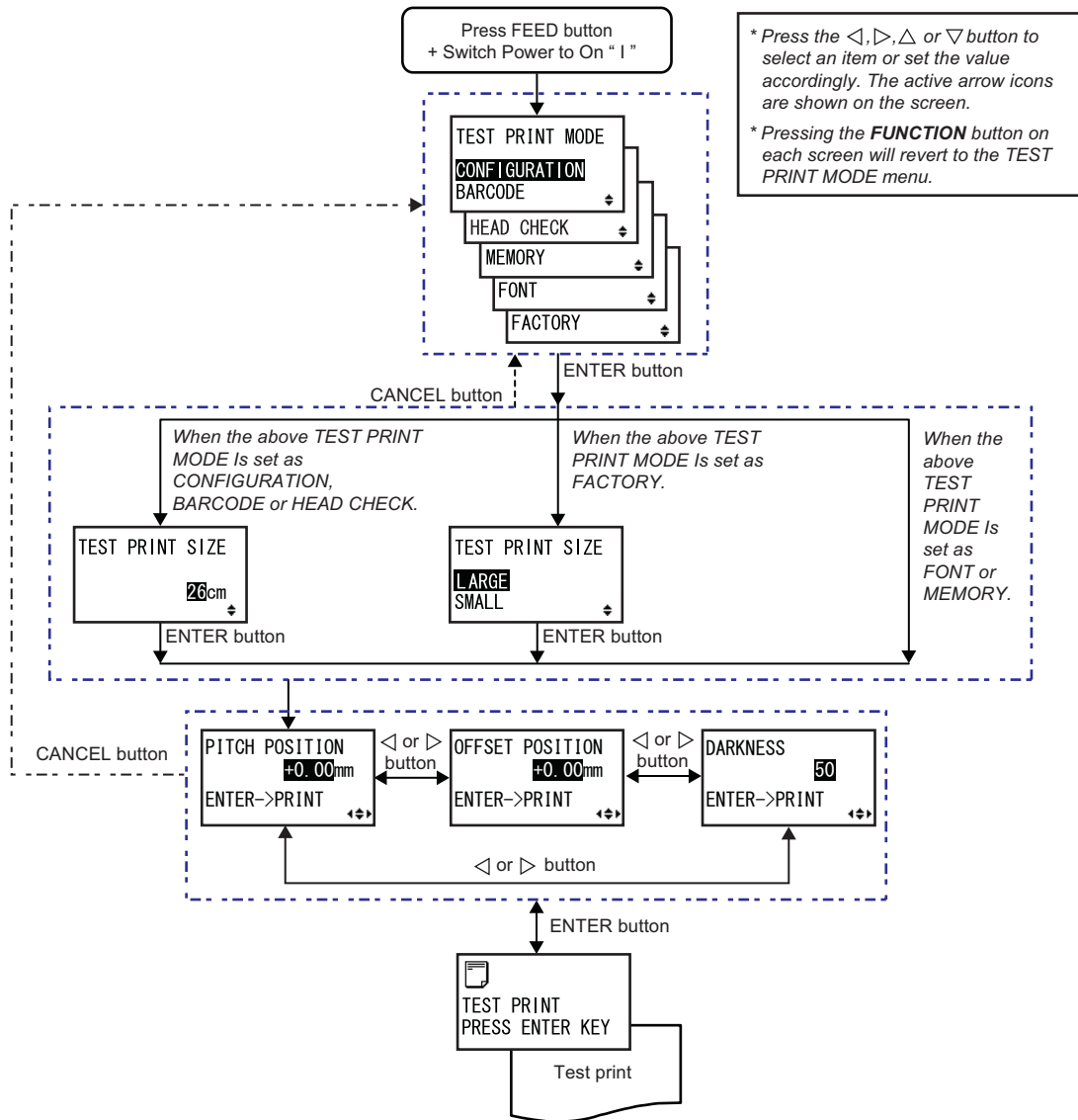

**Note**

- When EXTERNAL SIGNAL in the ADVANCED MODE menu is set to ENABLE, the product is unable to perform the test print correctly. Make sure that the EXTERNAL SIGNAL is set to DISABLE before performing test print.



**TEST PRINT MODE**

Select the test print contents.

- **CONFIGURATION**: Print the configuration settings of the product.
- **BARCODE**: Print the barcodes installed in this product.
- **HEAD CHECK**: Print the head check pattern of the selected media size area.
- **MEMORY**: Print the contents of the memory in this product.
- **FONT**: Print the contents of the fonts installed in this product.
- **FACTORY**: Perform the factory test print.

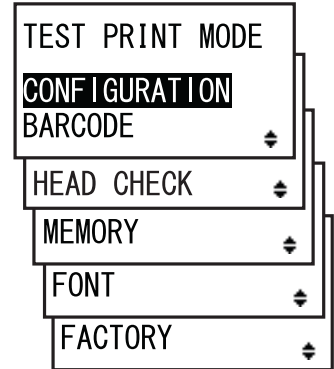
**TEST PRINT SIZE**

Set the width of the test print in 1 cm (0.4") steps.  
The setting range is from 13 to 26 cm (5.1" to 10.2").

**Note**

Shows only if TEST PRINT MODE is set to CONFIGURATION, BARCODE or HEAD CHECK.

**TEST PRINT SIZE**

Select the width of the test print from LARGE or SMALL.

- **LARGE**: Test print in 26 cm (10.2") wide.
- **SMALL**: Test print in 13 cm (5.1") wide.

**Note**

Shows only if TEST PRINT MODE is set to FACTORY.

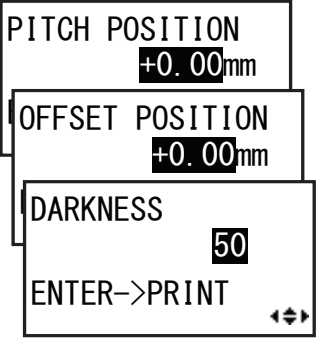

PITCH POSITION/OFFSET POSITION/DARKNESS	
<p>Adjust the print position, offset position and print darkness. The setting range for both PITCH POSITION and OFFSET POSITION is <math>\pm 3.75</math> mm (<math>\pm 0.15</math>" ) and is adjustable by 0.25 mm (0.01"). The setting range for DARKNESS is from 00 to 99.</p> <hr/> <p><b>Note</b> Press the <b>ENTER</b> button to start the test print.</p> <hr/>	

TEST PRINT PRESS ENTER KEY	
<p>The test print is in progress. Press the <b>ENTER</b> button while printing to pause the test print operation. Press the <b>ENTER</b> button again to continue.</p>	

## 4.2.12 Default Setting Mode

The product can be reset to the default setting as in the factory preset.

### CAUTION

It is generally not necessary to perform the initialization. Doing so will remove all the customer settings.

### Note

Refer to [Section 8.1 List of Initial Values](#) for the details of the initial value of each setting items.

The flowchart shows the sequence of the setting screens for the default setting mode. The table describes each setting screen in detail.

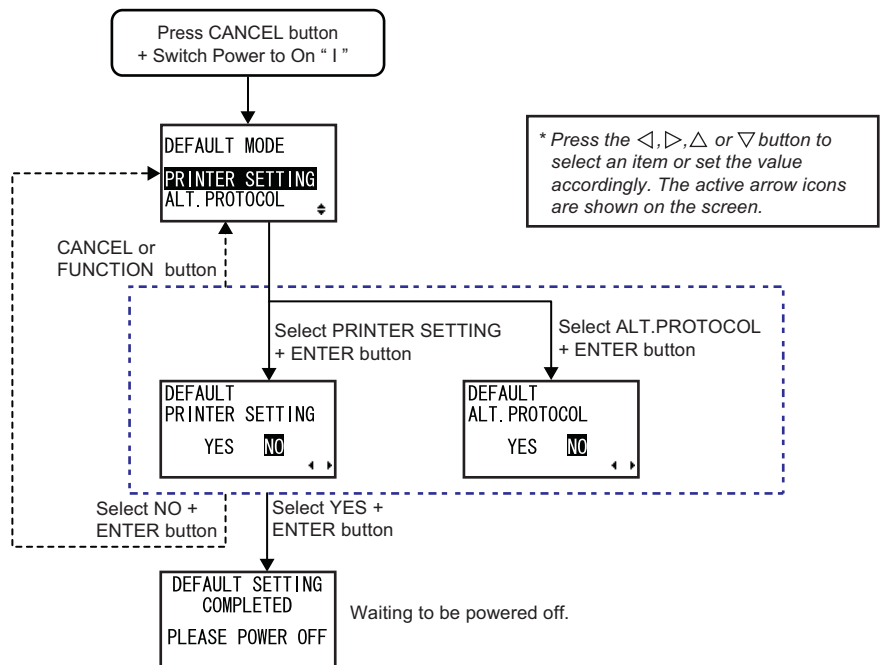

DEFAULT MODE	
Select the item to be initialized. <ul style="list-style-type: none"> <li>• <b>PRINTER SETTING</b>: Initialize the settings of the product.</li> <li>• <b>ALT. PROTOCOL</b>: Initialize the protocol code.</li> </ul>	

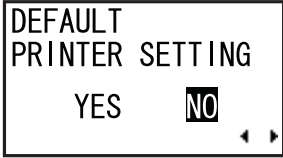
DEFAULT PRINTER SETTING	
<p>Select whether or not to initialize the settings of the product.</p> <ul style="list-style-type: none"> <li>• <b>YES</b>: Initialize the settings of the product.</li> <li>• <b>NO</b>: Cancel and return to the DEFAULT MODE screen.</li> </ul> <hr/> <p><b>Note</b> Shows only if DEFAULT MODE is set to PRINTER SETTING.</p> <hr/>	

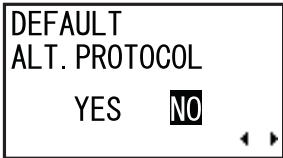
DEFAULT ALT. PROTOCOL	
<p>Select whether or not to initialize the protocol code.</p> <ul style="list-style-type: none"> <li>• <b>YES</b>: Initialize the protocol code.</li> <li>• <b>NO</b>: Cancel and return to the DEFAULT MODE screen.</li> </ul> <hr/> <p><b>Note</b> Shows only if DEFAULT MODE is set to ALT. PROTOCOL.</p> <hr/>	

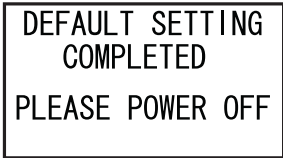
DEFAULT SETTING COMPLETED	
<p>Shows when the initialization has been completed.</p> <hr/> <p><b>Note</b> The setting will be effective only if you power on the product again.</p> <hr/>	

### 4.2.13 Download Mode

This download feature allows the operator to download data (firmware, font/logo, TrueType font, configuration) from the host computer through the interface, SD card or USB memory and write in the Flash ROM memory. When downloading is complete, the LCD screen will return to the original screen after three seconds. If an error occurs, an error message will show and the reason will be identified. The flowchart shows the sequence of the setting screens for the download mode. The table describes each setting screen in detail.

#### ⚠ CAUTION

Be sure to perform a virus check on the USB memory or SD card before connecting it to the product. SATO Corporation shall not be held responsible for any product malfunctions caused by a virus spread via USB memory or SD card.

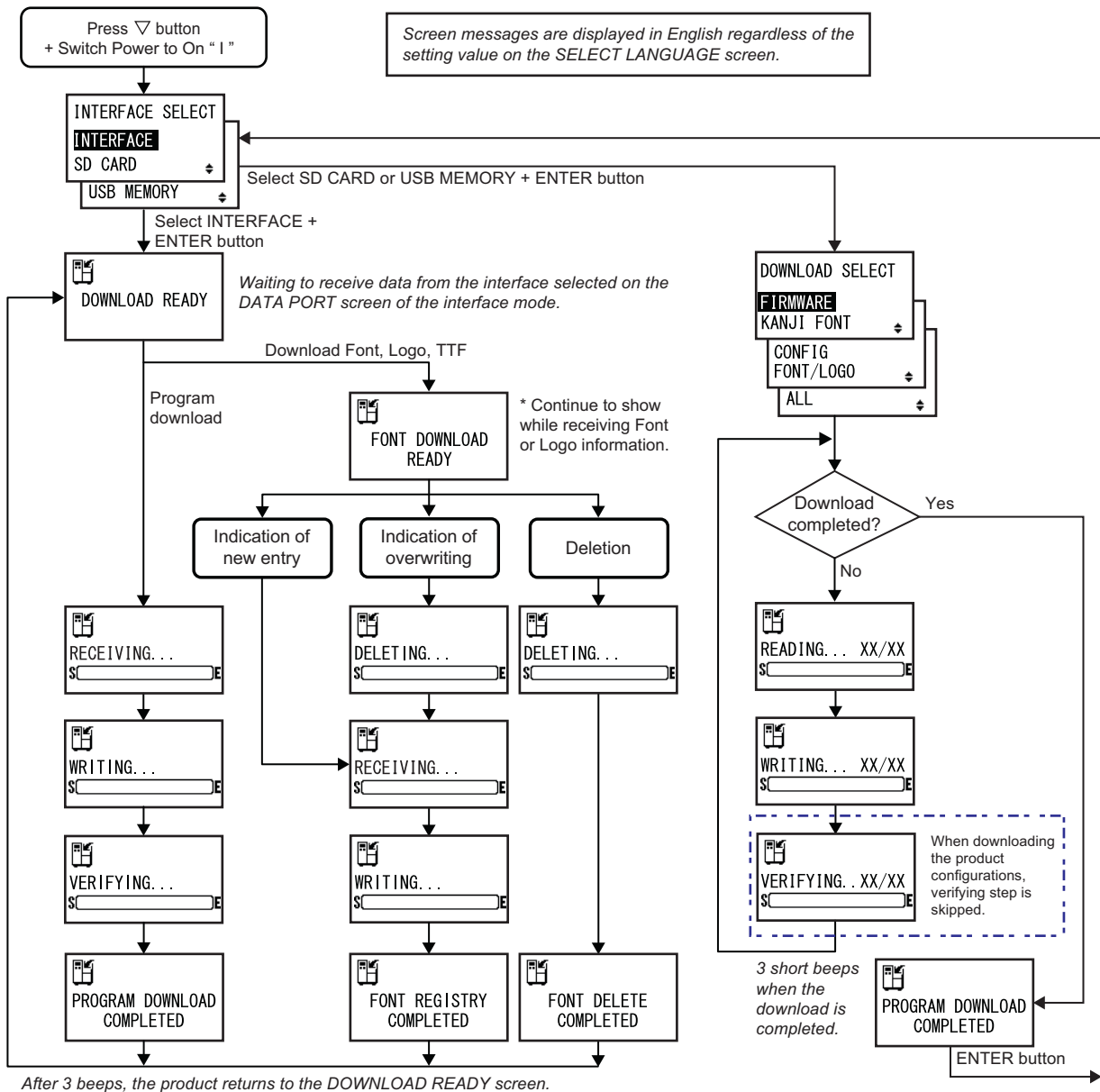

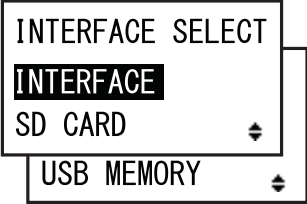
INTERFACE SELECT	
<p>Select the download method.</p> <ul style="list-style-type: none"> <li>• <b>INTERFACE:</b> Download the program from the interface.</li> <li>• <b>SD CARD:</b> Download the program from an SD card.</li> <li>• <b>USB MEMORY:</b> Download the program from a USB memory.</li> </ul>	

DOWNLOAD READY	
<p>The product is waiting to receive download data from the interface selected on the DATA PORT screen in the interface mode. The following data will be received from the PC and written to the main ROM.</p> <p>(1) Firmware data                  (2) Font/logo data                  (3) TrueType font</p> <p>When firmware data is received, it goes to the RECEIVING... screen. When font, logo and TrueType font are received, it goes to the FONT DOWNLOAD READY screen.</p> <hr/> <p><b>Note</b>                  Shows only if INTERFACE SELECT is set to INTERFACE.</p>	

FONT DOWNLOAD READY	
<p>The product is waiting to receive font data. When downloading the font for the first time, it goes to the RECEIVING... screen. When overwriting or deleting existing font data, it goes to the DELETING... screen.</p> <hr/> <p><b>Note</b>                  Shows only if INTERFACE SELECT is set to INTERFACE.</p>	

**DELETING . .**

The product is deleting the existing font data.  
 The bar on the lower portion of the screen indicates the data deletion progress.  
 When overwriting font data after deleting, it goes to the RECEIVING... screen.  
 When just deleting font data, it goes to the FONT DELETE COMPLETED screen.

**Note**

Shows only if INTERFACE SELECT is set to INTERFACE.

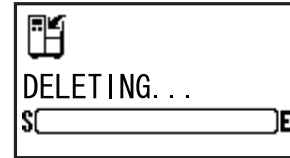
**RECEIVING . .**

The product is receiving downloaded data.  
 The bar on the lower portion of the screen indicates the data reception progress.  
 After receiving downloaded data, it goes to the WRITING... screen.

**Note**

Shows only if INTERFACE SELECT is set to INTERFACE.

**WRITING . .**

The product is writing downloaded data.  
 The bar on the lower portion of the screen indicates the data writing progress.  
 After writing downloaded data, it goes to the FONT REGISTRY COMPLETED screen.

**Note**

Shows only if INTERFACE SELECT is set to INTERFACE.

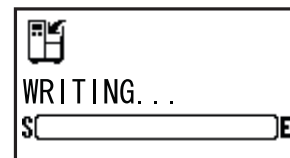
**VERIFYING . .**

The product is verifying the firmware data.  
 The bar on the lower portion of the screen indicates the data verification progress.  
 After verifying the firmware data, it goes to the PROGRAM DOWNLOAD COMPLETED screen.

**Note**

Shows only if INTERFACE SELECT is set to INTERFACE.



PROGRAM DOWNLOAD COMPLETED	
<p>This screen shows the completion of the download. Three beeps will sound when the program download is completed. If downloading through INTERFACE, it will return to the DOWNLOAD READY screen. If downloading through SD CARD or USB MEMORY, press the <b>ENTER</b> button to return to the INTERFACE SELECT screen.</p>	

FONT REGISTRY COMPLETED	
<p>This screen shows the completion of the font registry. Three beeps will sound when the font registry is completed. The product returns to the DOWNLOAD READY screen.</p> <hr/> <p><b>Note</b> Shows only if INTERFACE SELECT is set to INTERFACE.</p>	

FONT DELETE COMPLETED	
<p>This screen shows the completion of the font deletion. Three beeps will sound when the font deletion is completed. The product returns to the DOWNLOAD READY screen.</p> <hr/> <p><b>Note</b> Shows only if INTERFACE SELECT is set to INTERFACE.</p>	

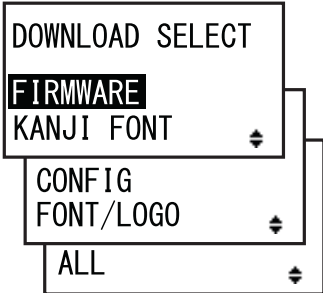
DOWNLOAD SELECT	
<p>Select the item to be downloaded.</p> <ul style="list-style-type: none"> <li>• <b>FIRMWARE</b>: Download “Firmware”.</li> <li>• <b>KANJI FONT</b>: Download “Kanji font” and “Kanji outline font”.</li> <li>• <b>CONFIG</b>: Download product configurations.</li> <li>• <b>FONT/LOGO</b>: Download font/logo data.</li> <li>• <b>ALL</b>: Download all data.</li> </ul> <hr/> <p><b>Note</b> Shows only if INTERFACE SELECT is set to SD CARD or USB MEMORY.</p>	



**READING . . XX/XX (DOWNLOAD)**

The product is reading the downloaded data.  
 The bar on the lower portion of the screen indicates the data reading progress.  
 XX/XX shows the file number being read and total number of files.  
 After reading the data, it goes to the WRITING... screen.

**Note**

Shows only if INTERFACE SELECT is set to SD CARD or USB MEMORY.

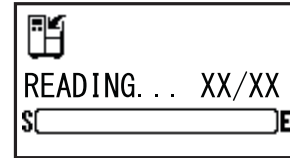
**WRITING . . XX/XX (DOWNLOAD)**

The product is writing the downloaded data.  
 The bar on the lower portion of the screen indicates the data writing progress.  
 XX/XX shows the file number being written and total number of files.  
 After writing the data, it goes to the VERIFYING... screen.

**Note**

Shows only if INTERFACE SELECT is set to SD CARD or USB MEMORY.

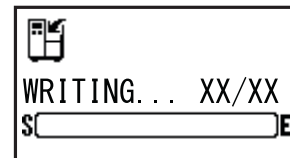
**VERIFYING . . XX/XX (DOWNLOAD)**

The product is verifying the downloaded data.  
 The bar on the lower portion of the screen indicates the data verification progress.  
 XX/XX shows the file number being verified and total number of files.  
 After verifying the data, it goes to the PROGRAM DOWNLOAD COMPLETED screen.

**Note**

Shows only if INTERFACE SELECT is set to SD CARD or USB MEMORY.



### 4.2.14 Upload Mode

The upload feature allows the operator to upload data (firmware, font/logo, TrueType font, configuration, status5 log) from the product and write it to an SD card or USB memory. When uploading is complete, the LCD screen will return to the original screen after three seconds. If an error occurs, an error message will show and the reason will be identified.

**CAUTION**

Be sure to perform a virus check on the USB memory or SD card before connecting it to the product. SATO Corporation shall not be held responsible for any product malfunctions caused by a virus spread via USB memory or SD card.

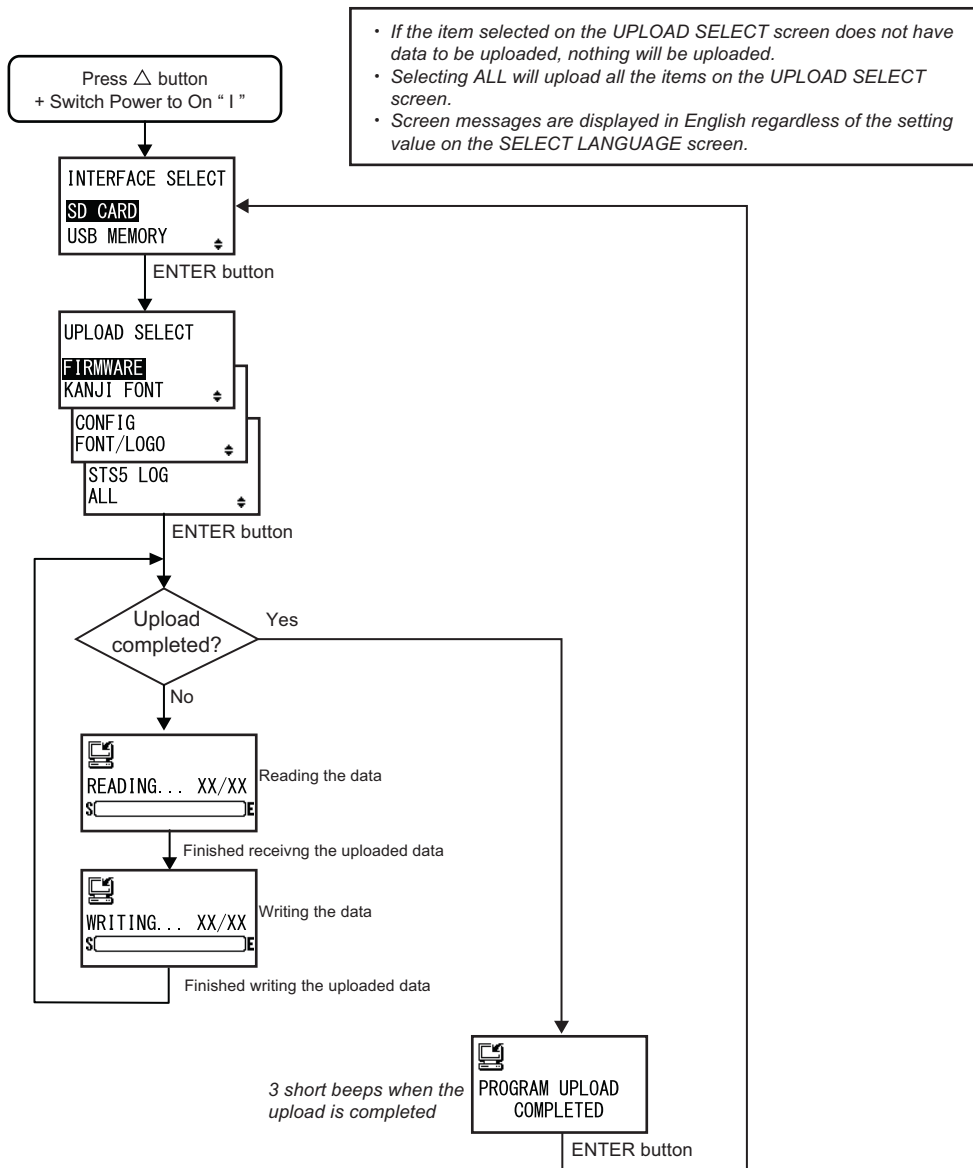

**INTERFACE SELECT**

Select the upload method.

- **SD CARD**: Upload data to an SD card.
- **USB MEMORY**: Upload data to a USB memory.

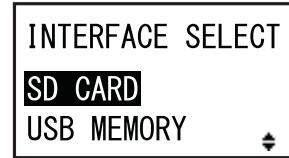
**UPLOAD SELECT**

Select the item to be uploaded.

- **FIRMWARE**: Upload "Firmware".
- **KANJI FONT**: Upload "Kanji font" and "Kanji outline font".
- **CONFIG**: Upload product configurations.
- **FONT/LOGO**: Upload font/logo data.
- **STS5 LOG**: Upload Status5 log.
- **ALL**: Upload all data.

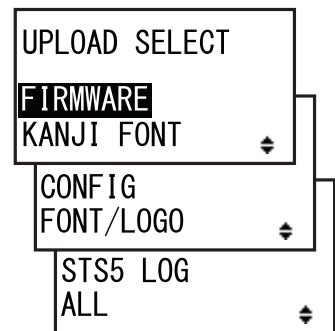
**READING . . XX/XX (UPLOAD)**

The product is reading the uploaded data.  
The bar on the lower portion of the screen indicates the data reading progress.  
XX/XX shows the file number being read and total number of files.  
After reading the data, it goes to the WRITING... screen.

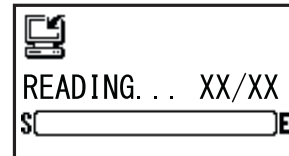
**WRITING . . XX/XX (UPLOAD)**

The product is writing the uploaded data.  
The bar on the lower portion of the screen indicates the data writing progress.  
XX/XX shows the file number being written and total number of files.

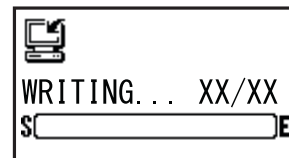

PROGRAM UPLOAD COMPLETED	
<p>This screen shows the completion of the upload. Three beeps will sound when the program upload is completed.</p> <p>Press the <b>ENTER</b> button to return to the INTERFACE SELECT screen.</p>	 <p>PROGRAM UPLOAD COMPLETED</p>

# 5

## Adjusting the Product

### 5.1 Adjusting the Display Brightness

In normal mode (online or offline), press the ◀/▶ buttons repeatedly to adjust the display brightness.

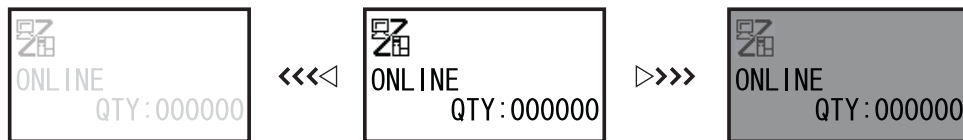

#### Note

- You can adjust the brightness in thirty-two steps (sixteen left and sixteen right).
- The brightness changes one step for every press of the ◀ button or ▶ button.
- Default setting will set the brightness to the middle level.

## 5.2 Adjusting the Buzzer Volume

In normal mode (online or offline), press the  $\Delta$  button repeatedly to adjust the volume of the buzzer.

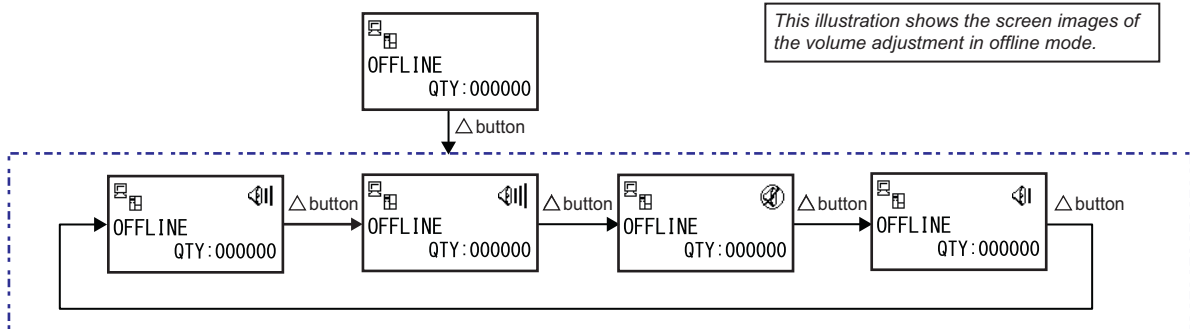

**1** When the product is in online or offline mode, press the  $\Delta$  button to show the current buzzer volume of the product.

The buzzer volume icon is shown on the top right corner of the screen.

**2** Pressing the  $\Delta$  button will cycle through the volume level and the buzzer will beep according to the volume.

### Note

- When default setting is activated, the buzzer volume will set to the initial value as level 2.
- The buzzer volume level icon will not show if another screen is refreshed.
- When the buzzer setting has changed by commands, the setting will be reflected after the product is rebooted.

## 5.3 LCD Power Saving Mode

This function is designed to reduce power consumption by setting the LCD backlight to off when the product is not operated for a specified period of time. The time required for the LCD backlight to light off can be set at LCD POWER SAVING setting screen in the advanced mode.

Refer to [Section 4.2.8 Advanced Mode](#) for the flowchart to access the setting. The setting procedure of the LCD power saving mode is as follows:

- 1** In offline mode, press the **ENTER** button.  
The product changes to setting mode menu.
- 2** Select the **ADVANCED MODE** using the  $\Delta/\nabla/\leftarrow/\rightarrow$  buttons and then press the **ENTER** button.
- 3** Press the **ENTER** button again until LCD POWER SAVING shows on the screen.
- 4** Press the  $\Delta/\nabla$  buttons to select a value.  
The setting range is from 00 to 15 MIN.  
When "00" is selected, this function is disabled and the LCD backlight is always on.
- 5** Press the **ENTER** button to save the setting.

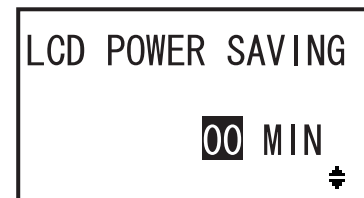

### Conditions to set the LCD backlight to off

Under the following conditions, the LCD backlight lights off when the time specified on the LCD POWER SAVING setting screen has elapsed. With this function, only the LCD backlight lights off and the on-screen message remains the same.

- The product has not received the print data\* (ESC+A to ESC+Z) in various interfaces.  
\* Each protocol's status return request, cancel request and incorrect data are omitted.
- No button is pressed.
- The product is not in error mode.
- The product is neither printing nor feeding media.
- The product is in online mode, offline mode or hex dump mode.  
This function is disabled in download mode.

### Conditions to set the LCD backlight to on

Any of the following conditions will light the LCD backlight on again.

- The product receives the print data\* from various interfaces.  
\* Each protocol's status return request, cancel request and incorrect data are omitted.
- Any button on the operator panel is pressed.
- Error occurred such as "Head open".
- The product starts the printing operation.

Pressing any button while the LCD backlight is off will only light the LCD backlight back on. The function of the button is invalid.

(For example, the product does not go offline by pressing the **LINE** button when the LCD backlight is off in online mode.)

## 5.4 Adjusting the Base Reference Point

### 5.4.1 About the Base Reference Point

The base reference point is the point at which one determines the print position and stop/cut position. The base reference point differs depending on the operation mode or media sensor you use.

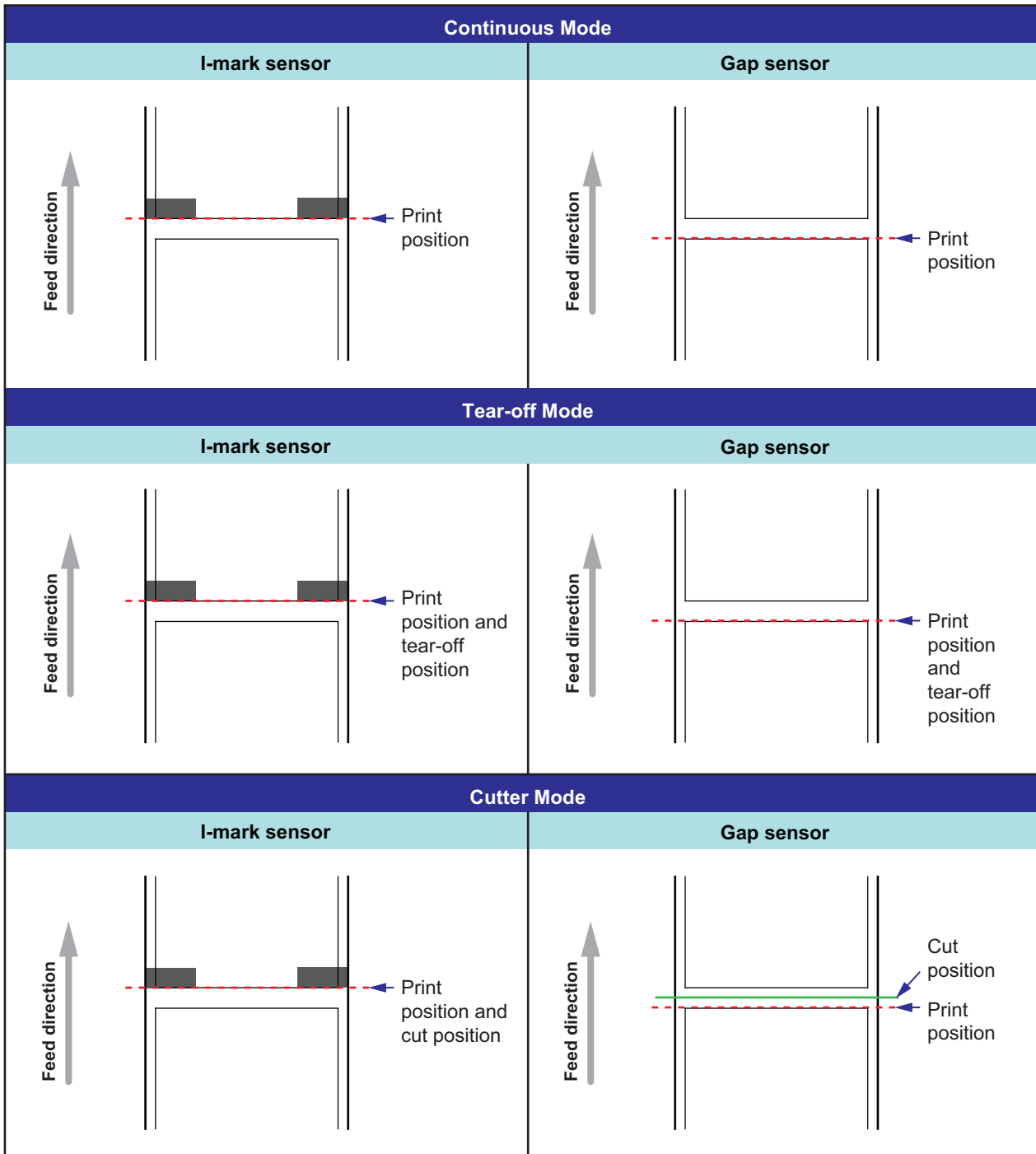



## 5.4.2 Adjusting the Print Position

Adjustment Location	Adjustment Range
Adjustment Mode: Pitch Position	+3.75 mm to -3.75 mm (+0.15" to -0.15")

Print position is adjustable within the range of +3.75 mm to -3.75 mm (+0.15" to -0.15") in the **Adjustment Mode**. The shift experienced by the media, ribbon or print layout can be offset with the adjustment of the pitch position.

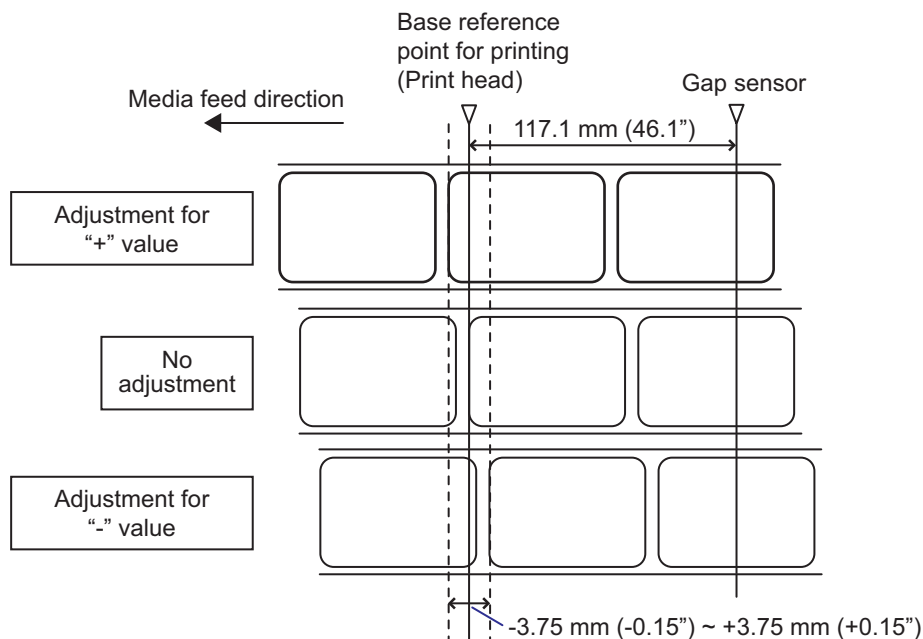

### Note

The above base reference point (print position) is the stop position when the media sensor type is set to Gap.

Adjust the print position using the following procedure:

- 1** Make sure that the product is in offline mode.
- 2** Press the  $\nabla$  button to enter the adjustment mode.  
PITCH POSITION shows on the screen.



**3** Change the setting value. Press the  $\triangle/\nabla$  buttons to set the desired value.

Set the offset value with '+' to move the print position opposite the feed direction, and value with '-' to move the print position in the feed direction.

The setting value is adjustable by 0.25 mm (0.01") regardless of print resolution.

The setting range is from -3.75 mm (-0.15") to +3.75 mm (+0.15").

**4** Press the **ENTER** button to save the setting and go to the next adjustment screen.

**5.4.3 Adjusting the Media Stop Position for Option**

Adjustment Location	Adjustment Range
Adjustment Mode: Offset Position	+3.75 mm to -3.75 mm (+0.15" to -0.15")

The stop position for options (such as cutter) is adjustable within the range of +3.75 mm to -3.75 mm (+0.15" to -0.15") in the **Adjustment Mode**.

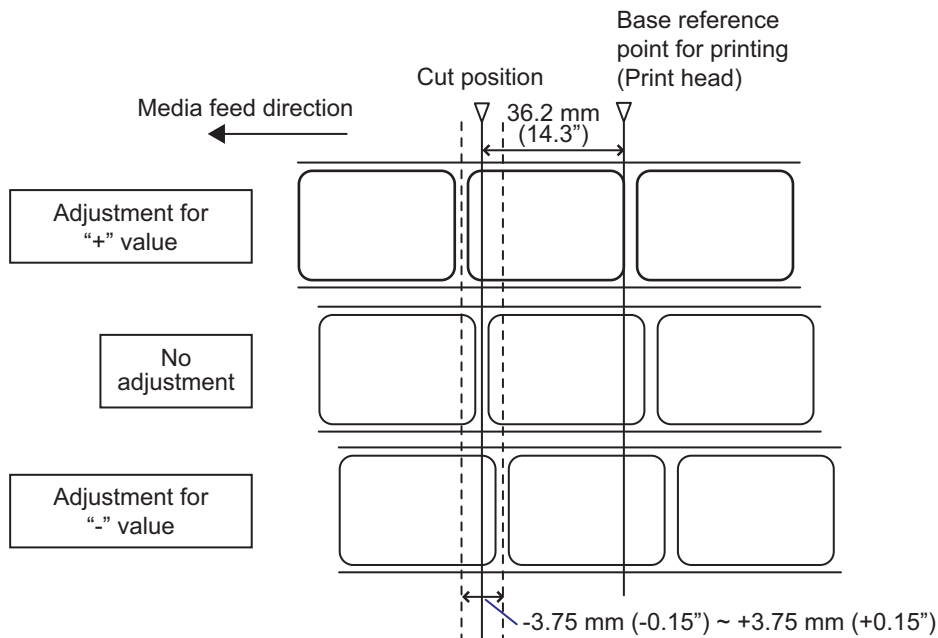

**Note**

- The above cut position for printing indicates the media stop position when the media sensor type is set to Gap.
- You can also adjust when the operation mode is specified to Tear-off.

Adjust the stop position using the following procedure:

- 1** Make sure that the product is in offline mode.
- 2** Press the  $\nabla$  button to enter the adjustment mode.  
PITCH POSITION shows on the screen.



- 3** Press the **ENTER** button to go to the next adjustment screen.  
OFFSET POSITION shows on the screen.



- 4** Change the setting value. Press the  $\triangle/\nabla$  buttons to set the desired value.  
Set the offset value with '+' to move the stop position opposite the feed direction, and value with '-' to move the stop position in the feed direction.  
The setting value is adjustable by 0.25 mm (0.01") regardless of print resolution.  
The setting range is from -3.75 mm (-0.15") to +3.75 mm (+0.15").
- 5** Press the **ENTER** button to save the setting and proceed to the next adjustment screen.

### 5.4.4 Notes on the Stop/Cut Position of Different Media

#### Cut Position when Using the Label in Cutter Mode

The regular cut position is between labels (only cut on the liner).

When you cut the label, the glue adheres to the blade of the cutter and the blade will decrease the performance of the cutter. Adjust the cut position so as not to cut the label.

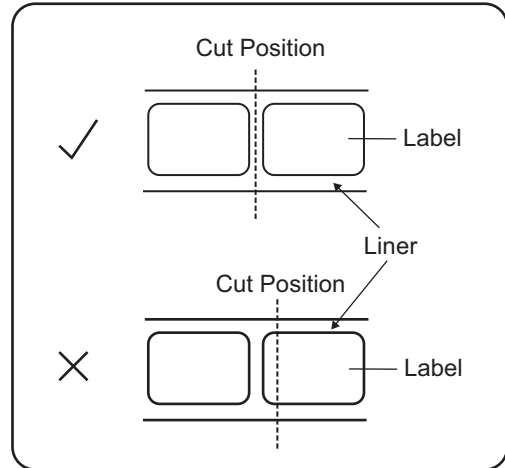

#### Cut Position when Using the Media with Perforated Line in Cutter Mode

Adjust the cut position so as not to cut the media on the perforated line and on the area near side from the perforated line (the area is shown in the figure below).

When the media is cut on the area not to be cut, it could cause a paper jam or damage.

- **Media Roll**

The area not to be cut is on the perforated line and on the area within 1 mm (0.04") near side from the perforated line.

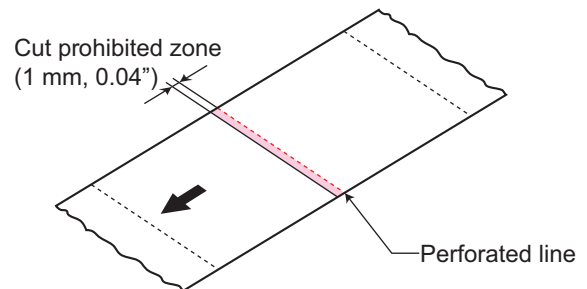

- **Fan-fold Media**

The area not to be cut is on the perforated line and on the area within 4 to 25 mm (0.16" to 0.98") near side from the perforated line.

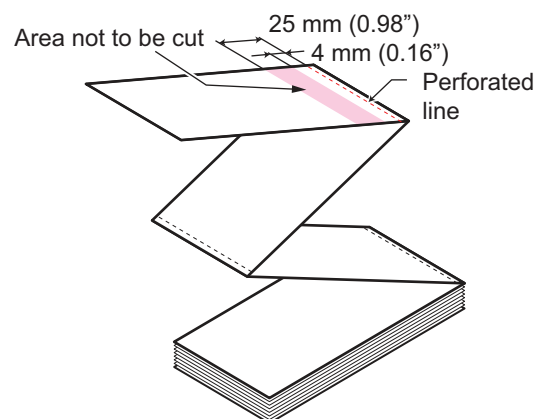

### 5.4.5 Limitation on Base Reference Point Adjustment

After adjusting the print position and stop position, the distance between these two positions should not exceed one pitch size (including liner) of the media.

Refer to the figure and table below for the adjustment range of the distance between the print position and the stop position for options.

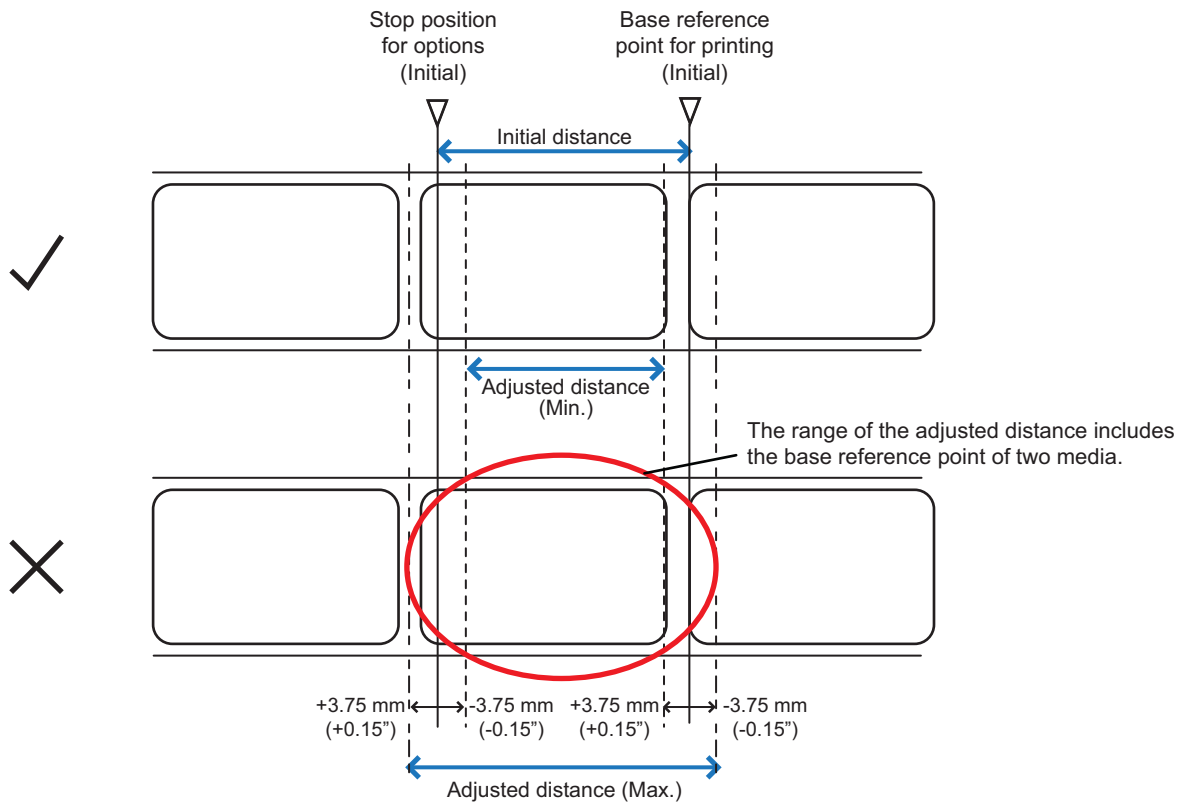

Adjustment range of the distance between the print position and the stop position for options:

Types of Options	Adjusted Distance (Min.)	Initial Distance	Adjusted Distance (Max.)
Tear-off mode	49.1 mm (1.9")	56.6 mm (2.2")	64.1 mm (2.5")
Cutter mode	28.7 mm (1.1")	36.2 mm (1.4")	43.7 mm (1.7")

### 5.4.6 Changing Backfeed Distance

When you are using cutter mode, adjust the backfeed distance in consideration of the cut position (OFFSET POSITION) and the print position (PITCH POSITION) to prevent the media being shifted away (fall off) from the platen roller after cutting motion.

The following examples show the effect of print position and cut position on backfeed distance.

**Example 1**

For PITCH POSITION= -3.00mm (-0.12") / OFFSET POSITION= 0mm

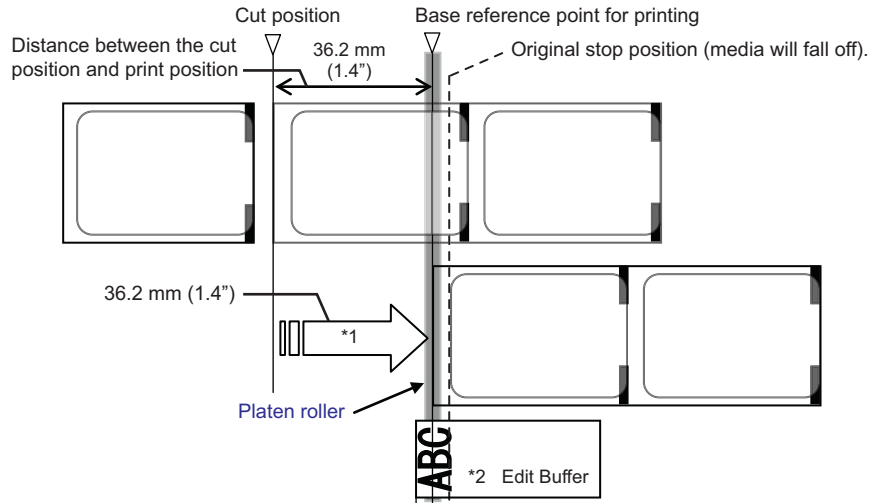

- \*1. The original backfeed distance before adjustment is 39.2 mm (1.5"), however it is adjusted to 36.2 mm (1.4") in this case to prevent the media from falling off the platen roller area.
- \*2. To resolve the misalignment of print due to decreased backfeed length, adjust print starting line to +3mm (+0.12") from the original stop position.

**Example 2**

For PITCH POSITION= 0mm / OFFSET POSITION= +3.00mm (+0.12")

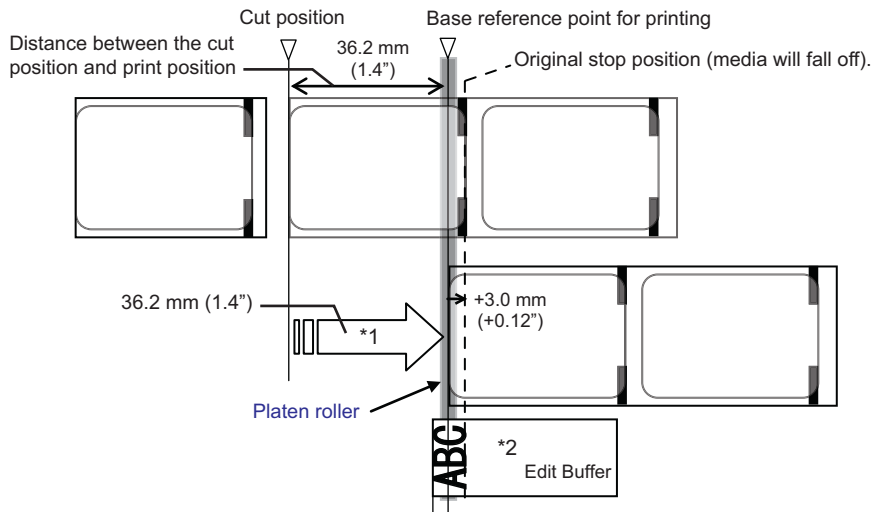

- \*1. The original backfeed distance before adjustment is 39.2 mm (1.5"), however it is adjusted to 36.2 mm (1.4") in this case to prevent the media from falling off the platen roller area.
- \*2. To resolve the misalignment of print due to decreased backfeed length, adjust print starting line to +3mm (+0.12") from the original stop position.

**Comparison between single cut and multiple cut**

**Example 1**

For PITCH POSITION= -3.00mm (-0.12") / OFFSET POSITION= 0mm

a) Single media cut

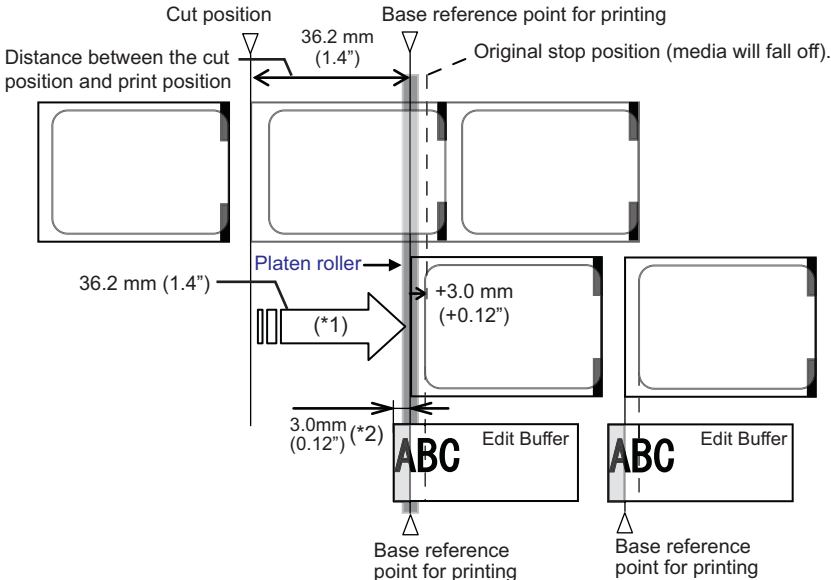

\*1. The original backfeed distance before adjustment is 39.2 mm (1.5"), however it is adjusted to 36.2 mm (1.4") in this case to prevent the media from falling off the platen roller area.  
 \*2. To resolve the misalignment of print due to decreased backfeed length, adjust print starting line to +3mm (+0.12") from the original stop position.

a) Multiple media cut

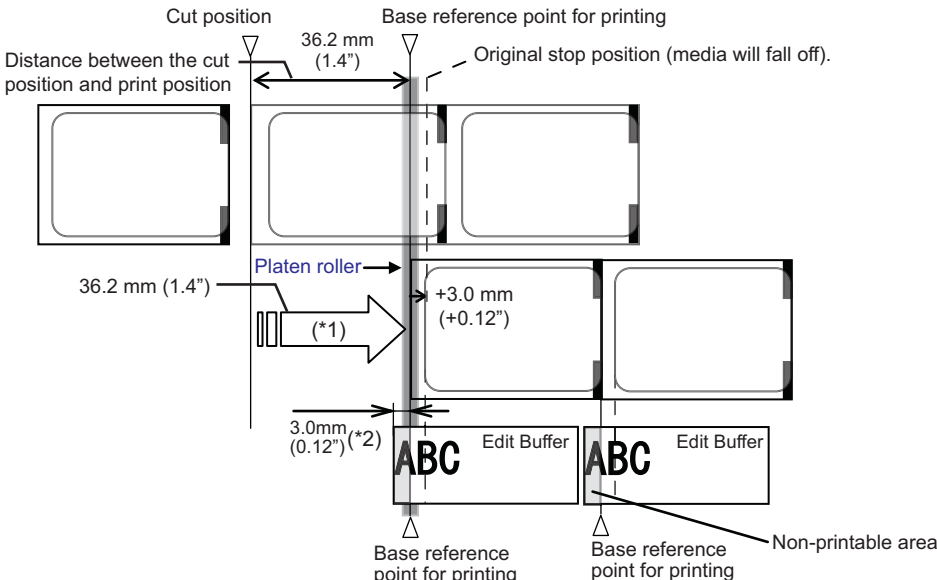

\*1. The original backfeed distance before adjustment is 39.2 mm (1.5"), however it is adjusted to 36.2 mm (1.4") in this case to prevent the media from falling off the platen roller area.  
 \*2. To resolve the misalignment of print due to decreased backfeed length, adjust print starting line to +3mm (+0.12") from the original stop position.

**Example 2**

For PITCH POSITION= 0mm / OFFSET POSITION= -3.00mm (-0.12")

a) Single media cut

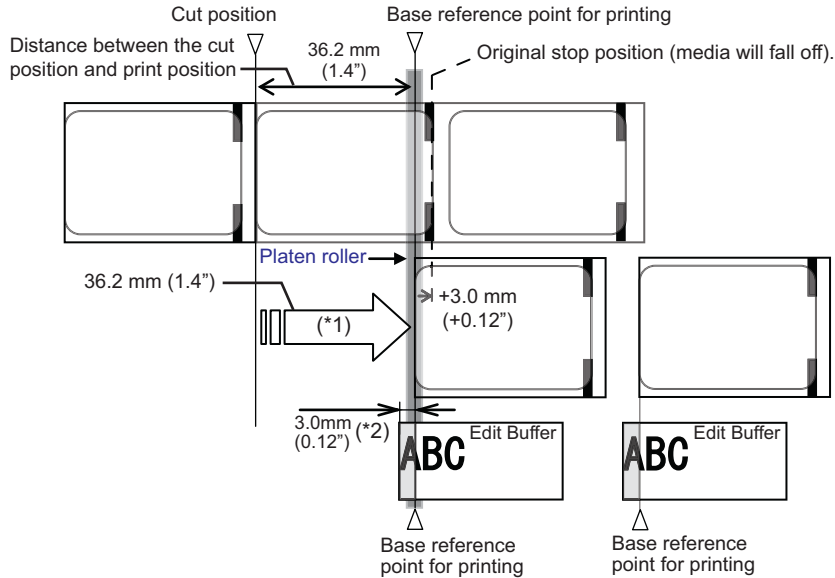

\*1. The original backfeed distance before adjustment is 39.2 mm (1.5"), however it is adjusted to 36.2 mm (1.4") in this case to prevent the media from falling off the platen roller area.

\*2. To resolve the misalignment of print due to decreased backfeed length, adjust print starting line to +3mm (+0.12") from the original stop position.

a) Multiple media cut

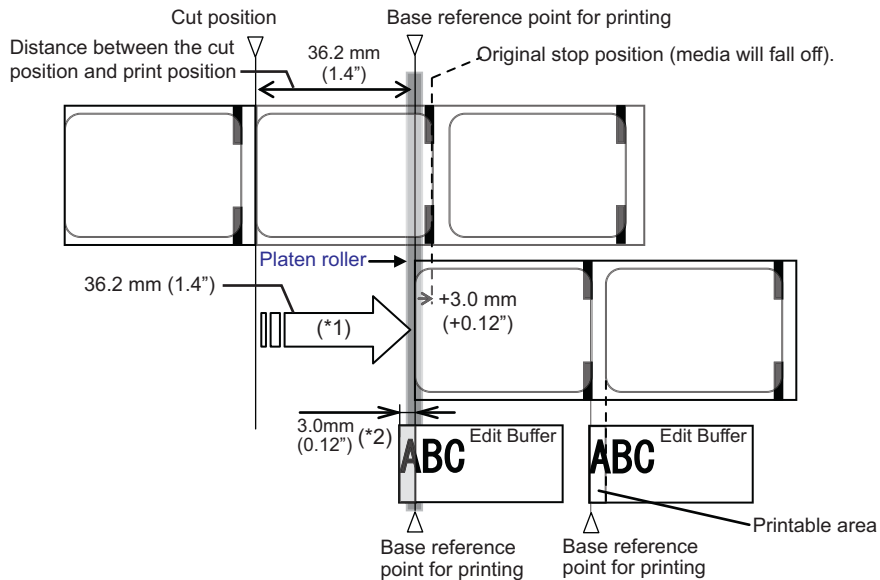

\*1. The original backfeed distance before adjustment is 39.2 mm (1.5"), however it is adjusted to 36.2 mm (1.4") in this case to prevent the media from falling off the platen roller area.

\*2. To resolve the misalignment of print due to decreased backfeed length, adjust print starting line to +3mm (+0.12") from the original stop position.



## 5.5 Adjusting the Print Quality

You can adjust the print quality by adjusting the print darkness and print speed.

### 5.5.1 Adjusting the Print Darkness

The adjustment procedure for the print darkness is as follows:

#### Note

You can fine tune the print darkness by setting the **DARKNESS** in the adjustments mode. Refer to [Section 4.2.3 Adjustment Mode](#) for details.

- 1 When the product is in online mode, press the **LINE** button to change the product to offline mode.
- 2 Press the **ENTER** button.  
The product changes to setting mode menu.



- 3 Select the **USER MODE** using the  $\Delta/\nabla/\leftarrow/\rightarrow$  buttons.  
USER MODE shows on the screen and the icon is highlighted in reverse.

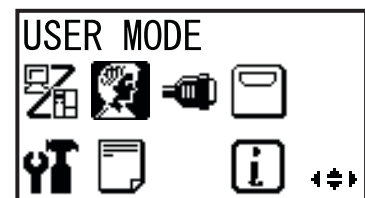

- 4 Press the **ENTER** button to enter the user mode.  
OFFSET VOLUME shows on the screen.

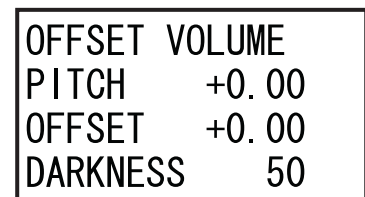

- 5** Press the **ENTER** button again until PRINT DARKNESS shows on the screen.
- 6** Press the  $\Delta/\nabla$  buttons to select a value.  
The setting range is from 1 to 10. 1 is the lightest and 10 is the darkest.
- 7** Press the **ENTER** button to save the setting.
- 8** Press the **FUNCTION** button to return to the setting mode menu.



### 5.5.2 Adjusting the Print Speed

The adjustment of the print speed not only changes the speed of printing but also affects the print quality. The setting range of the print speed is from 3 to 6 inches/sec.

The adjustment procedure for the print speed is as follows:

- 1** When the product is in online mode, press the **LINE** button to change the product to offline mode.
- 2** Press the **ENTER** button.  
The product changes to setting mode menu.

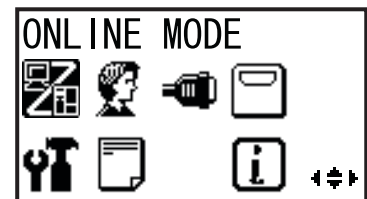

- 3** Select the **USER MODE** using the  $\Delta/\nabla/\leftarrow/\rightarrow$  buttons.  
USER MODE shows on the screen and the icon is highlighted in reverse.

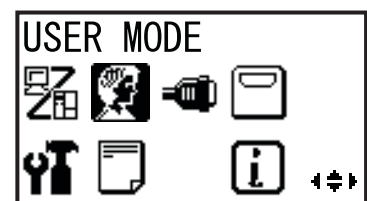

- 4** Press the **ENTER** button to enter the user mode.  
OFFSET VOLUME shows on the screen.

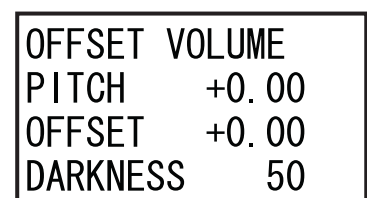

- 5** Press the **ENTER** button again until PRINT SPEED shows on the screen.
- 6** Press the  $\triangle/\nabla$  buttons to select a value.
- 7** Press the **ENTER** button to save the setting.
- 8** Press the **FUNCTION** button to return to the setting mode menu.

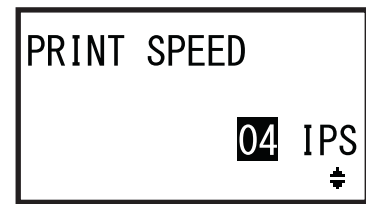

**This page is intentionally left blank.**

# 6

## Maintenance

---

### 6.1 Cleaning the Product

A dirty print head or platen roller not only affects the print quality but also causes errors. Use a cleaning kit or cleaning sheet to clean the product regularly.

---

#### CAUTION

- Do not power on or off the product, connect or disconnect the power cord while your hands are wet. Doing so could cause an electric shock.
- Disconnect the power cord from the AC outlet before you begin cleaning.  
The print head and its surroundings are hot after printing. Wait until the product cools down.
- Touching the edge of the print head with your bare hand could cause injury.
- Be careful not to touch the cutter blade when cleaning the product.
- Use a cotton swab or cotton cloth from a cleaning kit for cleaning. Do not clean with a hard object. Doing so could cause damage.
- Before cleaning, remove the media and ribbon.

---

#### Note

The cleaning kit and cleaning sheet are optional. Contact your SATO reseller or technical support center to purchase the options.

---

## 6.2 Cleaning the Print Head and Platen Roller

### 6.2.1 Cleaning Intervals

Clean the product at the following regular intervals.

- After you print one media roll or print media for 150 meters (492.1 feet).  
Use the cleaning kit to clean these parts:
  - Print head
  - Platen roller
  - Media sensors
- After you print six media rolls or print media for 900 meters (2952.8 feet).  
Use the cleaning sheet to clean these parts:
  - Print head  
Use the cleaning kit to clean these parts:
  - Media guide
  - Feed roller
  - Media route
  - Ribbon route

---

#### Note

The above cleaning intervals are only for reference. Clean the product when necessary even if you are not at a regular interval.

---

### 6.2.2 Cleaning Using the Cleaning Kit

The cleaning procedure using the cleaning kit is as follows:

---

#### CAUTION

Never use organic solvents, such as thinner and benzene to clean the product.

---

#### Note

The cleaning kit is optional. Contact your SATO reseller or technical support center to purchase the options. For details on the cleaning kit, refer to the manual attached to the cleaning kit.

---

- 1** Make sure that the product is powered off, and then disconnect the power cord from the AC outlet.

## 2 Open the top cover ①.

### ⚠ CAUTION

Open the top cover fully to prevent accidental drop of the cover.

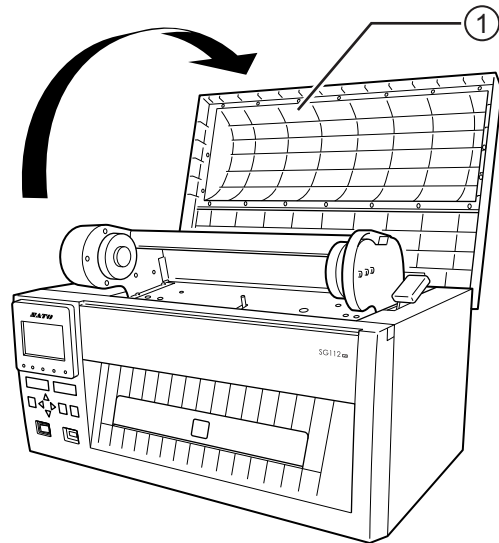

## 3 Pull the head release lever ② forward to unlock the print head.

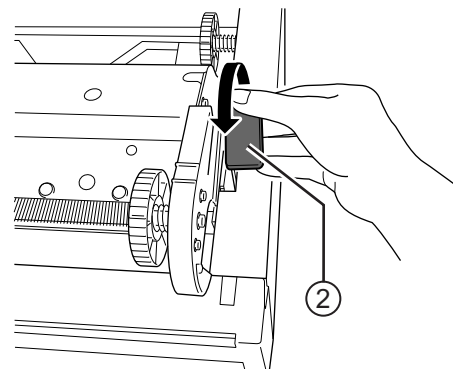

## 4 Lift up the print head assembly ③ to the maximum.

### ⚠ CAUTION

- The print head and its surroundings are hot after printing. Be careful not to touch it, to avoid being burned.
- Touching the edge of the print head with your bare hand could cause injury.

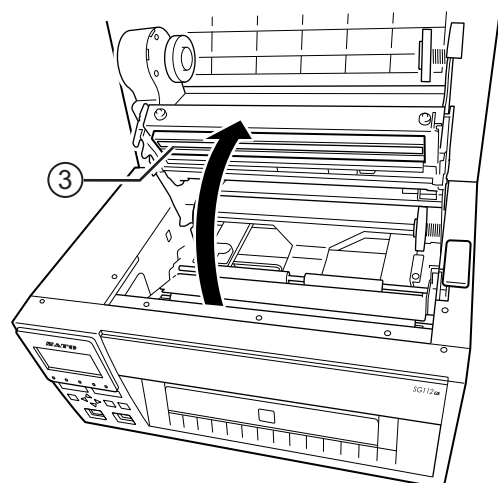

## 5 Remove the media, carbon ribbon and make the print head visible.

- 6** Clean the dirt on the **print head** ④ using a cotton swab/cloth dabbed with cleaning liquid.

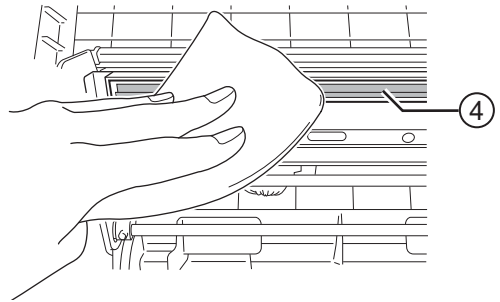

- 7** Clean the dirt on the **platen roller** ⑤ using a cotton swab/cloth dabbed with cleaning liquid.

Rotate the roller to clean the entire roller.

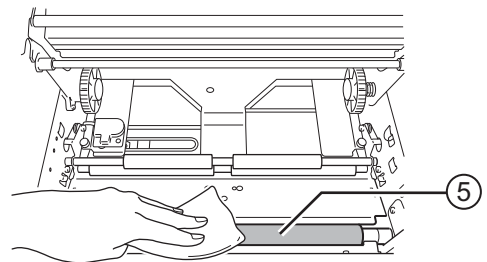

- 8** Clean the dirt on the **media sensor window** ⑥ using a cotton swab/cloth dabbed with cleaning liquid.

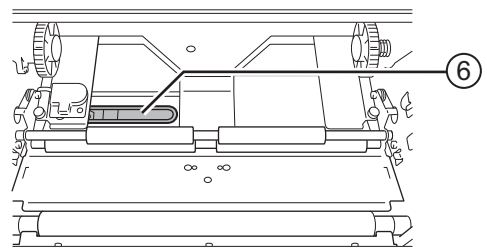

- 9** Lift up and remove the **media lid** ⑦ that is covering the feed roller.

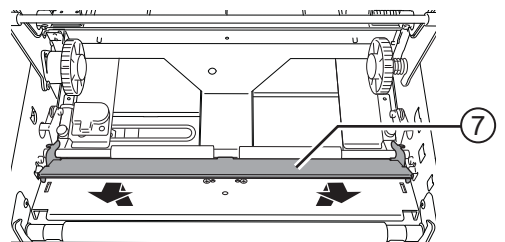

- 10** Dab the cleaning liquid on the cotton swab/cloth, and wipe off the dirt from the **feed roller** ⑧ and the upper **nip roller** ⑨.

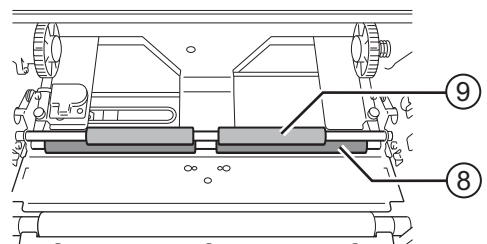



**After cleaning**

- 1** Place the **media lid** ⑦ back to its original position.

Attach the two side of the media lid to the nip roller shaft. And then press on the two corner of the media lid until it snaps to position.

- 2** Load the carbon ribbon back to the product.

- 3** Close the **print head assembly** ③. Press on both sides as shown by the arrow to close it tightly until it clicks.

- 4** Close the **top cover**.

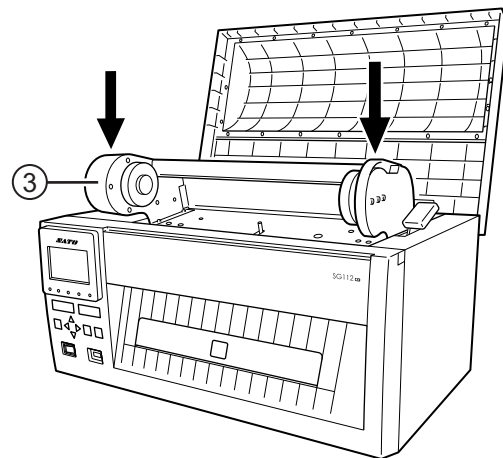
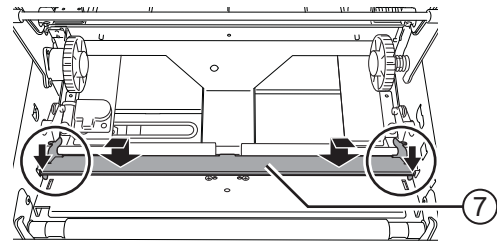

**⚠ CAUTION**

When closing the top cover, be careful not to pinch your fingers.

### 6.2.3 Cleaning Using the Cleaning Sheet

The cleaning procedure using the cleaning sheet is as follows:

---

#### Note

The cleaning sheet is optional. Contact your SATO reseller or technical support center to purchase the options.

For details on the cleaning sheet, refer to the manual attached to the cleaning sheet.

---

- 1** Make sure that the product is in power off mode, and then disconnect the power cord from the AC outlet.
- 2** Open the **top cover** ①.

---

#### CAUTION

Open the top cover fully to prevent accidental drop of the cover.

---

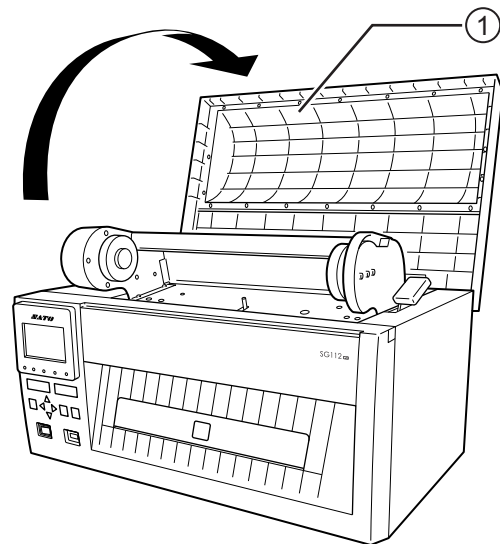

- 3** Pull the **head release lever** ② forward to unlock the print head.

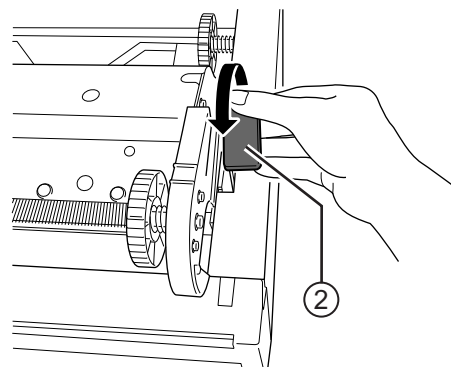

- 4** Lift up the **print head assembly** ③ to the maximum.

**⚠ CAUTION**

- The print head and its surroundings are hot after printing. Be careful not to touch it, to avoid being burned.
- Touching the edge of the print head with your bare hand could cause injury.

- 5** Remove the media, carbon ribbon and make the print head visible.

- 6** Place the **cleaning sheet** ④ between the **print head** and the **platen roller** ⑤.

**Note**

- The matte side of the cleaning sheet should be facing upwards (print head).

- 7** Insert the cleaning sheet from the back of the front panel and the leading edge out from the **media discharge outlet** ⑥.

Make sure that there is enough area for you to pull the cleaning sheeting and area for the cleaning sheet to cleaning the print head.

- 8** Close the **print head assembly** ③. Press on both sides as shown by the arrow to close it tightly until it clicks.

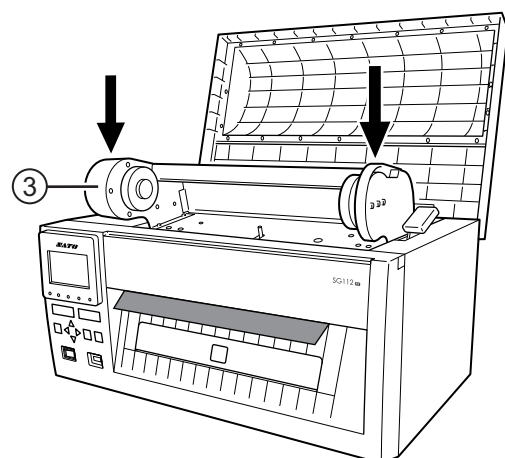
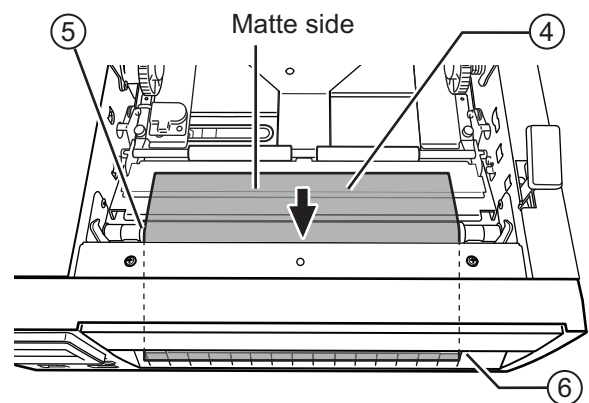
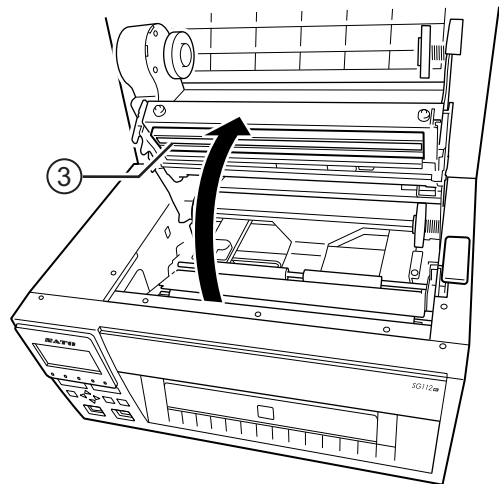

**9** Use two hands to pull the **cleaning sheet** ④ away from the product.

**10** After you pull out the cleaning sheet, repeat steps 3 through 9, two or three more times.

When no more dirt appears on the cleaning sheet after you have pulled it out, stop repeating these steps.

Adhesive residue of the print head is removed. If there is residue, please repeat a few more times.

**11** Use a cotton swab/cloth dabbed with cleaning liquid to clean the dirt on the **print head**.

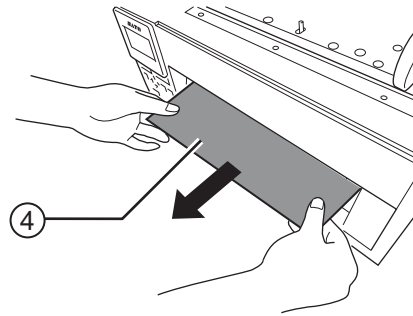

# 7

## Troubleshooting

This chapter explains the errors that can occur on the product and the displays for indicating the current status.





### 7.1 When an Error Message Appears







When there is an error with the product, the error message appears on the screen. The error message and the countermeasure message alternate every three seconds. These screens can be switched using the  $\triangle/\nabla$  buttons.





#### CAUTION

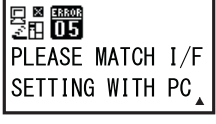



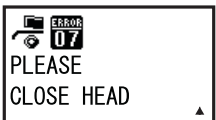
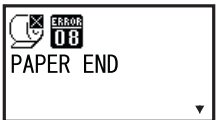

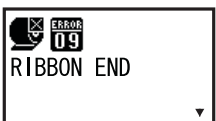
Where parts replacement is concerned, contact your SATO reseller or technical support center to perform internal inspections and repairs.

Check the cause and countermeasure, and then take appropriate action.



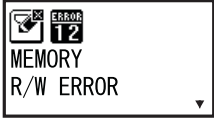

Error				
No.	Message	LED/Buzzer	Cause	Countermeasure
01	Machine error 	<b>ONLINE:</b> Off <b>STATUS:</b> Lights red. <b>LABEL:</b> Off <b>RIBBON:</b> Off  One long beep.	A defect has occurred in the product.	Power the product off and then on again. Contact your SATO reseller or technical support center if the error cannot be resolved.
				
02	Flash ROM error 	<b>ONLINE:</b> Off <b>STATUS:</b> Lights red. <b>LABEL:</b> Off <b>RIBBON:</b> Off  One long beep.	Flash ROM is not accessible.	Contact your SATO reseller or technical support center to replace the main (CONT) PCB.
			To clear the error: Power off the product.	





Error				
No.	Message	LED/Buzzer	Cause	Countermeasure
03	Parity error 	<b>ONLINE:</b> Flashes green <b>STATUS:</b> Lights red. <b>LABEL:</b> Off <b>RIBBON:</b> Off  Three short beeps.  To clear the error: Power off the product.	RS-232C settings are incorrect.	Set the interface settings of the product again.
			The RS-232C cable is not connected correctly.	Power off the product, connect the RS-232C cable correctly, and then power on the product again.
04	Overrun error 	<b>ONLINE:</b> Flashes green <b>STATUS:</b> Lights red. <b>LABEL:</b> Off <b>RIBBON:</b> Off  Three short beeps.  To clear the error: Power off the product.	RS-232C settings are incorrect.	Set the interface settings of the product again.
			The RS-232C cable is not connected correctly.	Power off the product, connect the RS-232C cable correctly, and then power on the product again.
05	Framing error 	<b>ONLINE:</b> Flashes green <b>STATUS:</b> Lights red. <b>LABEL:</b> Off <b>RIBBON:</b> Off  Three short beeps.  To clear the error: Power off the product.	RS-232C settings are incorrect.	Set the interface settings of the product again.
			The RS-232C cable is not connected correctly.	Power off the product, connect the RS-232C cable correctly, and then power on the product again.
06	Buffer overflow 	<b>ONLINE:</b> Flashes green <b>STATUS:</b> Lights red. <b>LABEL:</b> Off <b>RIBBON:</b> Off  Three short beeps.  To clear the error: Power off the product.	The size of the received data from the host exceeds the size of the receive buffer.	Change the settings on the host so that data that exceeds the size of the receive buffer cannot be sent.
			The interface settings between the product and the host are incorrect.	Set the interface settings of the product and host again.

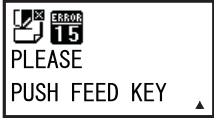

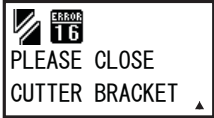

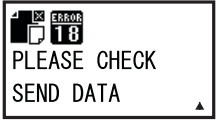

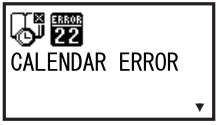
Error				
No.	Message	LED/Buzzer	Cause	Countermeasure
07	Head open	<b>ONLINE:</b> Off <b>STATUS:</b> Flashes red. <b>LABEL:</b> Off <b>RIBBON:</b> Off  Three short beeps.  To clear the error: Close the print head.	The print head is unlocked.	Lock the print head.
	 		The sensor for detecting the open/close status of the print head is defective.	Contact your SATO reseller or technical support center to replace the sensor.
08	Paper end	<b>ONLINE:</b> Off <b>STATUS:</b> Flashes red. <b>LABEL:</b> Lights red. <b>RIBBON:</b> Off  Three short beeps.  To clear the error: Open and close the print head.	The media is not loaded.	Load the media correctly.
			The media is not loaded correctly.	
			The sensitivity of the media sensor is not set correctly.	Adjust the media sensor level.
			The media has jammed.	Remove the jammed media.
09	Ribbon end	<b>ONLINE:</b> Off <b>STATUS:</b> Flashes red. <b>LABEL:</b> Off <b>RIBBON:</b> Lights red.  Three short beeps.  To clear the error: Open and close the print head.	The ribbon is not loaded.	Load a new ribbon.
			The ribbon is damaged.	
			The ribbon is not loaded correctly.	Load the ribbon correctly.
			The ribbon is torn.	Clean and adjust the ribbon path.
10	Sensor error	<b>ONLINE:</b> Off <b>STATUS:</b> Lights red. <b>LABEL:</b> Off <b>RIBBON:</b> Off  Three short beeps.  To clear the error: Open and close the print head.	The media sensor type is incorrect.	Set the media sensor type which is compatible with the media you use.
			Meandering media.	Clean and adjust the media path.
			The media sensor level is incorrect.	Contact your SATO reseller or technical support center to adjust the media sensor level.

Error					
No.	Message	LED/Buzzer	Cause	Countermeasure	
11	Print head error 	<b>ONLINE:</b> Off <b>STATUS:</b> Lights red. <b>LABEL:</b> Off <b>RIBBON:</b> Off  One long beep.	The print elements are worn out.	Change the print head check conditions to only check for missing elements in barcodes and try to adjust missing elements to white bars. Refer to <a href="#">Section 7.1.2 More Information about Head Check Function</a> for details.	
		To clear the error: Power off the product, or change print head check conditions.	The print head is damaged.		Contact your SATO reseller or technical support center to replace the print head.
12	Memory write error 	<b>ONLINE:</b> Off <b>STATUS:</b> Flashes red. <b>LABEL:</b> Off <b>RIBBON:</b> Off  One long beep.  To clear the error: Power off the product.	The USB memory is disconnected while writing.	Connect the USB memory.	
	Product memory: 		The copy area in the memory is not sufficient.	Make sure that the memory has sufficient copy area.	
	USB memory: 		Writing to the memory fails.	Replace the USB memory.	
			The USB memory is not formatted.	Format the USB memory in the memory mode. Refer to <a href="#">Section 4.2.7 Memory Mode</a> for details.	
	SD card write error 		<b>ONLINE:</b> Off <b>STATUS:</b> Flashes red. <b>LABEL:</b> Off <b>RIBBON:</b> Off  One long beep.  To clear the error: Power off the product.	The SD card is not connected.	Connect the SD card.
				The SD card is not connected correctly.	Connect the SD card correctly.
	The SD card is disconnected while writing.	Connect the SD card.			
	The SD card read/write fails.	Replace the SD card.			
	The SD card is not formatted.	Format the SD card in the memory mode. Refer to <a href="#">Section 4.2.7 Memory Mode</a> for details.			
	The SD card is write-protected.	Release the write-protect of the SD card.			

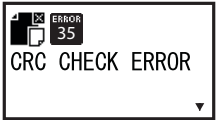

Error				
No.	Message	LED/Buzzer	Cause	Countermeasure
14	Download data error	<b>ONLINE:</b> Off <b>STATUS:</b> Lights red. <b>LABEL:</b> Off <b>RIBBON:</b> Off  One long beep.  To clear the error: Press the <b>ENTER</b> button.	The downloaded data is invalid.	Check the downloaded data.
			The download area is not sufficient.	Check the downloaded data size.
15	Cutter error	<b>ONLINE:</b> Off <b>STATUS:</b> Flashes red. <b>LABEL:</b> Off <b>RIBBON:</b> Off  Three short beeps.  To clear the error: Press the <b>FEED</b> button.	A media jammed at the cutter unit.	Remove the jammed media from the cutter unit. If the error is not solved, power the product off and then on again.
	  		The cutter blade does not return to the specified position.	Press the <b>FEED</b> button to move the cutter blade back to the specified position. If the error is not solved, power the product off and then on again.
16	Cutter open error	<b>ONLINE:</b> Off <b>STATUS:</b> Flashes red. <b>LABEL:</b> Off <b>RIBBON:</b> Off  Three short beeps.  To clear the error: Press the <b>FEED</b> button.	The cutter cover is not attached.	Attach the cutter cover.
	  		The sensor failure.	Contact your SATO reseller or technical support center to replace the sensor.
17	BCC check error	<b>ONLINE:</b> Flashes green <b>STATUS:</b> Lights red. <b>LABEL:</b> Off <b>RIBBON:</b> Off  Three short beeps.  To clear the error: Press the <b>LINE</b> button or cancel the print job.	The BCC code of the data to be sent (one item) is incorrect.	Check the data to be sent and the interface settings.  <b>LINE</b> button: Continue printing from the print data where the BCC error occurred.  Send the SUB command: Clear the BCC error and continue printing from where it stopped.

Error				
No.	Message	LED/Buzzer	Cause	Countermeasure
18	<p>Item No. error</p>  	<p><b>ONLINE:</b> Flashes green  <b>STATUS:</b> Lights red.  <b>LABEL:</b> Off  <b>RIBBON:</b> Off</p> <p>Three short beeps.</p> <p>To clear the error:            Press the <b>LINE</b> button or cancel the print job.</p>	<p>Sequence number of print data (one item) is not increased by one.</p> <p>*The sequence number is not in sequential order.</p>	<p>Check the data to be sent and the interface settings.</p> <p><b>LINE</b> button: Continue printing from the print data where the Item No. error occurred.</p> <p>Send the SUB command:            Clear the Item No. error and continue printing from where it stopped.</p>
21	<p>Kanji memory error</p> 	<p><b>ONLINE:</b> Off  <b>STATUS:</b> Lights red.  <b>LABEL:</b> Off  <b>RIBBON:</b> Off</p> <p>Three short beeps.</p> <p>To clear the error:            Power off the product.</p>	<p>Invalid Kanji data was imported from Kanji memory.</p>	<p>Contact your SATO reseller or technical support center to replace the main (CONT) PCB.</p>
22	<p>Calendar error</p>  	<p><b>ONLINE:</b> Off  <b>STATUS:</b> Lights red.  <b>LABEL:</b> Off  <b>RIBBON:</b> Off</p> <p>One long beep.</p> <p>To clear the error:            Power off the product.</p>	<p>The date and time of the calendar (option) are incorrect.</p> <p>The real-time clock (calendar) kit is not installed.</p>	<p>Power the product off and then on again, and check the print data.</p> <p>Contact your SATO reseller or technical support center to check if you have installed the real-time clock (calendar) kit or replace the real-time clock (calendar) kit.</p>
25	<p>Media error</p> 	<p><b>ONLINE:</b> Off  <b>STATUS:</b> Lights red.  <b>LABEL:</b> Flashes red.  <b>RIBBON:</b> Off</p> <p>Three short beeps.</p> <p>To clear the error:            Open and close the print head.</p>	<p>The media size of the print data is longer than the actual media size.</p>	<p>Check the media size of the print data and the actual media size again. Specify another print data.</p>
			<p>The media is fed a longer distance due to the incorrect sensor level.</p>	<p>Contact your SATO reseller or technical support center to adjust the media sensor level.</p>

Error				
No.	Message	LED/Buzzer	Cause	Countermeasure
26	<p>Overheat error</p>  	<p><b>ONLINE:</b> Flashes green  <b>STATUS:</b> Flashes red.  <b>LABEL:</b> Off  <b>RIBBON:</b> Off</p> <p>One long beep.</p> <p>To clear the error:  Stop the operation of the product and wait until the temperature decreases.</p>	<p>The temperature of the product has exceeded its tolerance value.</p>	<p>Stop the operation of the product to let the temperature decrease.</p>
27	<p>Command error</p>   <p><b>Note</b>  This screen shows only when COMMAND ERROR in ADVANCED MODE is set to ENABLE.</p>	<p><b>ONLINE:</b> Off  <b>STATUS:</b> Lights red.  <b>LABEL:</b> Off  <b>RIBBON:</b> Off</p> <p>Three short beeps.</p> <p>To clear the error:  Press the <b>LINE</b> button.</p>	<p>Incorrect command or parameter in the print data.  For details of the error, check the “Caaa: &lt;bb&gt;: cc” part at the bottom of the screen.  Caaa: position of error occurrence  &lt;bb&gt;: error command name  cc: error code</p>	<p>Check the print data. Refer to <a href="#">Section 7.1.1 More Information about Command Error</a> for details.</p>
35	<p>CRC check error</p>  	<p><b>ONLINE:</b> Flashes green  <b>STATUS:</b> Flashes red.  <b>LABEL:</b> Off  <b>RIBBON:</b> Off</p> <p>Three short beeps.</p> <p>To clear the error:  Press the <b>LINE</b> button or cancel the print job.</p>	<p>The CRC code of the data to be sent (one item) is incorrect.</p>	<p>Check the data to be sent and the communication settings.</p> <p><b>LINE</b> button: Continue printing from the print data where the CRC error occurred.</p> <p>Send the SUB command: Clear the CRC error and continue printing from where it stopped.</p>

Error				
No.	Message	LED/Buzzer	Cause	Countermeasure
36	<p>Cut motor error</p> 	<p><b>ONLINE:</b> Off  <b>STATUS:</b> Flashes red.  <b>LABEL:</b> Off  <b>RIBBON:</b> Off</p> <p>Three short beeps.</p> <p>To clear the error:            Power off the product.</p>	<p>The cutter motor deteriorated.</p>	<p>Contact your SATO reseller or technical support center to replace the cutter unit.</p>

## 7.1.1 More Information about Command Error

### Product motion when detecting a command error

When COMMAND ERROR is set to ENABLE in advanced mode, the command error information is shown on the error message (second line), and the print operation is paused.

This error can be cleared by pressing the **LINE** button, but the data in which an error is detected is discarded and cannot be printed.

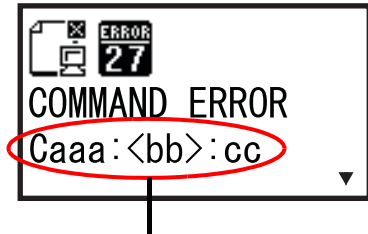

Command error information

### Location of error occurrence

“Caaa” in the command error message shows the location of command error.

The number of ESC commands from ESC+A is shown in “aaa”.

Note that the ESC+A command is not included in the number of ESC commands, which can be shown up to 999. If the number of ESC commands exceeds 999, it is shown as “999”.

### Example)

When a command error is detected by the Horizontal Print Position <H> command

```
-----: [ESC]A
C001: [ESC]V100
C002: [ESC]H99999 => Location of the command error
C003: [ESC]L0202
C004: [ESC]M,ABCDEF
C005: [ESC]Q1
C006: [ESC]Z
```

In this case, C002 is the location of the error.

### Error command name

The command name, in which an error is detected, is shown in “<bb>”.

\* A one-byte command name is left aligned.

### Error code

The cause of command error will be indicated in the code in “cc” where an error is being shown.

Code <cc>	Cause
01	Analyzed improper command.
02	Received improper parameter.
03	Analyzed improper graphic and external character data.
04	Specified memory area (card slot) is inappropriate. Tried to write to a write-protected media.
05	Number specified by registration command has already been taken.
06	Exceeded the registration area. (Memory full).
07	Data is not registered.
08	The specified print start position is outside the printable area.
09	The printing image is outside the printable area. (Barcode only).

## 7.1.2 More Information about Head Check Function

The head check function detects the integrity of the heating elements in the print head. However, malfunctions cannot be detected instantaneously — a few printed media may start showing printing defect before the product warns of a print head error.

After detection of a print head error, use a scanner to check all affected media.

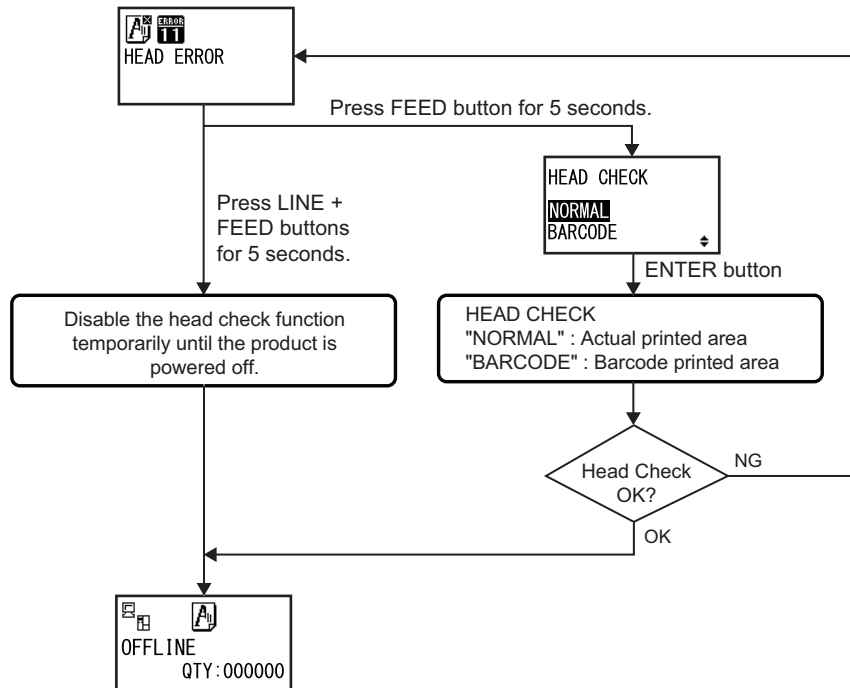

### When a print head error occurs during normal printing (barcodes, text and graphics)

- 1 Press and hold down the **FEED** button for five seconds.  
HEAD CHECK setting screen shows.
- 2 Select **BARCODE** using the  $\Delta/\nabla$  buttons and then press the **ENTER** button.
- 3 See if printing can be resumed normally.

If printing resumes, the print head fault does not fall on the barcode area for the current print job. As such, printing may be continued but with degraded print quality and readable barcodes.

If the head check error still occurs and the current print job has to be completed, printing can be forced to resume by holding down the **LINE** and **FEED** buttons for five seconds.



**Read the caution note below before you proceed with this operation.**





### CAUTION

Although restricting the head check type to **BARCODE** allows you to continue printing, or forcing the product to resume printing, you should only do so in order to complete an urgent print job. Check the printed media to make sure the output is usable in spite of the head error. As soon as possible, stop using the print head to prevent further damage. If necessary, replace the print head.

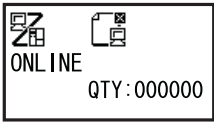
## 7.2 When a Warning Message Appears

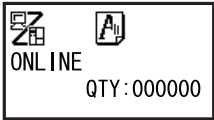
When a warning message is shown on the screen, the product continues issuing media. The warning message, its cause and the countermeasures are as follows:

Warning				
No.	Message	LED/Buzzer	Cause	Countermeasure
01	Ribbon near end 	<b>ONLINE:</b> Lights green. <b>STATUS:</b> Off <b>LABEL:</b> Off <b>RIBBON:</b> Flashes red.  No beep.  To clear the error: Open and close the print head.	The remaining amount of ribbon is not enough.	Replace the ribbon. Refer to <a href="#">Section 3.2 Loading the Ribbon</a> for details.
02	Receive buffer nearly full 	<b>ONLINE:</b> Lights green. <b>STATUS:</b> Flashes green. <b>LABEL:</b> Off <b>RIBBON:</b> Off  No beep.	Available space for receive buffer is low.	Do not send data from the host until the analysis of received data is completed.
03	Command error 	<b>ONLINE:</b> Lights green. <b>STATUS:</b> Off <b>LABEL:</b> Off <b>RIBBON:</b> Off  One short beep.  To clear the error: The icon will be cleared by receiving the next item or canceling the job.	Command error has been detected.	Check the print data.

Warning				
No.	Message	LED/Buzzer	Cause	Countermeasure
04	Head error 	<b>ONLINE:</b> Lights green. <b>STATUS:</b> Off <b>LABEL:</b> Off <b>RIBBON:</b> Off  No beep.	A head check error is detected when "NORMAL" has been selected for the HEAD CHECK setting screen. Change the HEAD CHECK setting to "BARCODE" and continue the print job.	Contact your SATO reseller or technical support center to replace the print head.
05	Clean print head and platen roller 	<b>ONLINE:</b> Off <b>STATUS:</b> Off <b>LABEL:</b> Off <b>RIBBON:</b> Off  One short beep.  To clear the error: Press the <b>ENTER</b> button.	The set notification interval has been reached.	Clean the print head and platen roller. Refer to <a href="#">Section 6.2 Cleaning the Print Head and Platen Roller</a> for details.
07	Change print head 	<b>ONLINE:</b> Off <b>STATUS:</b> Off <b>LABEL:</b> Off <b>RIBBON:</b> Off  One short beep.  To clear the error: Press the <b>ENTER</b> button.	The set notification interval has been reached.	Contact your SATO reseller or technical support center to replace the print head.
08	Change platen roller 	<b>ONLINE:</b> Off <b>STATUS:</b> Off <b>LABEL:</b> Off <b>RIBBON:</b> Off  One short beep.  To clear the error: Press the <b>ENTER</b> button.	The set notification interval has been reached.	Contact your SATO reseller or technical support center to replace the platen roller.



Warning				
No.	Message	LED/Buzzer	Cause	Countermeasure
09	<p>Change cutter</p>  <p>CHANGE CUTTER</p>	<p><b>ONLINE:</b> Off <b>STATUS:</b> Off <b>LABEL:</b> Off <b>RIBBON:</b> Off</p> <p>One short beep.</p> <p>To clear the error: Press the <b>ENTER</b> button.</p>	<p>The set notification interval has been reached.</p>	<p>Contact your SATO reseller or technical support center to replace the cutter.</p>

## 7.3 Troubleshooting

Check the items below when the product does not operate correctly.

If the problem cannot be resolved, contact your SATO reseller or technical support center.

### WARNING

- Do not power on or off the product, connect or disconnect the power cord while your hands are wet. Doing so could cause an electric shock.
- Where parts replacement is concerned, contact your SATO reseller or technical support center to perform internal inspections and repairs.

### 7.3.1 No Power/Nothing on the Screen

No.	What to check	Countermeasure
1	Is the power cord fully connected to the AC outlet?	Connect the power cord to the AC outlet fully.
2	Is the power cord fully connected to the product?	Connect the power cord to the AC input terminal of the product fully.
3	Is the power cord damaged?	Replace the power cord. Contact a SATO reseller or technical support center for the specific power cord for this product. Do not use power cords that are not designed specifically for this product.
4	Is there electricity at the AC outlet that supplies the power to the product?	Check if there is electricity at the AC outlet. Connect to another AC outlet.
5	Is the main (CONT) PCB defective?	Replace the main (CONT) PCB. Contact a SATO reseller or technical support center for replacement.

### 7.3.2 Cannot Feed the Media

No.	What to check	Countermeasure
1	Are the media and ribbon designed for the product?	Use media and ribbon designed for the product.
2	Are the media and ribbon loaded correctly?	Load the media and ribbon correctly.
3	Is the media or ribbon deformed?	Use the media or ribbon that is not deformed. You cannot feed the media or ribbon that is deformed.
4	Is the media guide set correctly?	Adjust the media guide.
5	Is the correct sensor type set?	Set the correct sensor type.
6	Is the sensitivity of the sensor set correctly?	Contact your SATO reseller or technical support center to adjust the media sensor level.

No.	What to check	Countermeasure
7	Is the platen roller dirty?	If the platen roller is dirty, clean it with the cleaning kit. For product cleaning, refer to <a href="#">Section 6.2 Cleaning the Print Head and Platen Roller</a> .
8	Is the platen roller damaged?	Replace the platen roller. Contact a SATO reseller or technical support center for replacement.
9	Does the interface operate correctly?	Check the interface according to the <a href="#">Interface Troubleshooting</a> .
10	Is the data or signal sent from the computer incorrect?	Power off and then on the product again. Check the data sent from the computer and interface conditions.
11	Is the main (CONT) PCB defective?	Replace the main (CONT) PCB. Contact a SATO reseller or technical support center for replacement.

### 7.3.3 Can Feed the Media but Cannot Print

No.	What to check	Countermeasure
1	Are the media and ribbon designed for use with the product?	Use the media and ribbon designed for the product.
2	Is the correct sensor type set?	Set a correct sensor type.
3	Is the print head dirty or is there a label attached to it?	If the print head is dirty, clean it using a cotton swab/cloth dabbed with cleaning liquid. If a label is attached to the print head, remove it. If the glue of label is attached to the print head, clean it using a cleaning kit. Do not clean using a hard object. Doing so could cause damage to the print head. For product cleaning, refer to <a href="#">Section 6.2 Cleaning the Print Head and Platen Roller</a> .
4	Is the media sensor dirty?	If the media sensor is dirty, clean it using the cleaning kit. For product cleaning, refer to <a href="#">Section 6.2 Cleaning the Print Head and Platen Roller</a> .
5	Does the interface operate correctly?	Check the interface according to the <a href="#">Interface Troubleshooting</a> .
6	Is the data or signal sent from the computer incorrect?	Power on the product again. Check the data sent from the computer and interface conditions.
7	Is the print head defective?	Replace the print head and reset the counter. Contact a SATO reseller or technical support center for replacement.

No.	What to check	Countermeasure
8	Is the main (CONT) PCB defective?	Replace the main (CONT) PCB. Contact a SATO reseller or technical support center for replacement.

### 7.3.4 Bad Print Quality

No.	What to check	Countermeasure
1	Are the media and ribbon designed for use with the product?	Use media and ribbon designed for the product.
2	Are the media and ribbon loaded correctly?	Check if the media and ribbon are loaded correctly.
3	Is the print speed too fast?	Adjust the print speed.
4	Is the print darkness too low or too high?	Adjust the print darkness.
5	Is the platen roller dirty?	If the platen roller is dirty, clean it using the cleaning kit. For product cleaning, refer to <a href="#">Section 6.2 Cleaning the Print Head and Platen Roller</a> .
6	Is the print head dirty or is there a label attached to it?	If the print head is dirty, clean it using a cotton swab/cloth dabbed with cleaning liquid. If a label is attached to the print head, remove it. If the glue of label is attached to the print head, clean it using a cleaning kit. Do not clean using a hard object. Doing so could cause damage to the print head. For product cleaning, refer to <a href="#">Section 6.2 Cleaning the Print Head and Platen Roller</a> .
7	Is the print head defective?	Replace the print head and reset the counter. Contact a SATO reseller or technical support center for replacement.
8	Is the platen roller damaged?	Replace the platen roller. Contact a SATO reseller or technical support center for replacement.
9	Is the main (CONT) PCB defective?	Replace the main (CONT) PCB. Contact a SATO reseller or technical support center for replacement.

### 7.3.5 Incorrect Print Position

No.	What to check	Countermeasure
1	Are the media and ribbon designed for use with the product?	Use media and ribbon designed for the product.
2	Are the media and ribbon loaded correctly?	Check if the media and ribbon are loaded correctly.

No.	What to check	Countermeasure
3	Is the media or ribbon deformed?	Use the media or ribbon that is not deformed. You cannot feed the media or ribbon that is deformed.
4	Is the media guide set correctly?	Adjust the media guide.
5	Is the correct sensor type set?	Set the correct sensor type.
6	Is the sensitivity of the sensor set correctly?	Contact your SATO reseller or technical support center to adjust the media sensor level.
7	Is the offset set correctly?	Adjust the offset.
8	Is the pitch offset or base reference point offset set correctly?	Adjust the pitch offset or base reference point offset.
9	Is the platen roller dirty?	If the platen roller is dirty, clean it using the cleaning kit. For product cleaning, refer to <a href="#">Section 6.2 Cleaning the Print Head and Platen Roller</a> .
10	Is the media sensor dirty?	If the media sensor is dirty, clean it using the cleaning kit. For product cleaning, refer to <a href="#">Section 6.2 Cleaning the Print Head and Platen Roller</a> .
11	Is the data or signal sent from the computer incorrect?	Power on the product again. Check the data sent from the computer and interface conditions.
12	Is the platen roller damaged?	Replace the platen roller. Contact a SATO reseller or technical support center for replacement.

## 7.4 Interface Troubleshooting

When an interface error occurs on the product, check with the checklist related to that interface.

### 7.4.1 USB Interface

No.	Item to check
1	Check that the USB cable is connected correctly.
2	Check that the cable is not damaged.
3	Check the configuration of the product. Check the setting of the USB interface through the INTERFACE MODE menu.
4	If there are multiple USB ports on the computer, connect to another port.
5	Disconnect other USB devices from the computer.
6	Power on the product and computer again.
7	Install the USB driver again.

### 7.4.2 LAN Ethernet Interface

No.	Item to check
1	Check that the LAN cable is connected correctly.
2	Check that the cable is not damaged.
3	Check the configuration of the product. Check the setting of the LAN Ethernet interface through the INTERFACE MODE menu.
4	Check that the allocated IP address is accessible by PING.
5	Check that the power of the HUB is on.
6	Check that the HUB is not defective.
7	Power on the product again.

### 7.4.3 RS-232C Interface

No.	Item to check
1	Check that the RS-232C cable is connected correctly.
2	Check that the cable is not damaged.
3	Check the configuration of the product. Check the setting of the RS-232C interface through the INTERFACE MODE menu.
4	If there are multiple RS-232C ports on the computer, connect to another port.
5	Power on the product and computer again.

#### 7.4.4 IEEE1284 Interface

No.	Item to check
1	Check that the product cable is connected to the LPT port of the computer correctly.
2	Check that the cable is not damaged.
3	If you are using a Windows printer driver, check that the correct port is selected.
4	Check the configuration of the product. Check the setting of the IEEE1284 interface through the INTERFACE MODE menu.
5	Connect to another port.
6	Power on the product again.

#### 7.4.5 External Signal Interface (EXT)

No.	Item to check
1	Check that the product and external device are connected with a cable correctly.
2	Check that the cable is not damaged.
3	Check that the power of the external device is on.
4	Check the configuration of the product. Check the setting of the external signal (EXT) interface.
5	Power on the product and external device again.

**This page is intentionally left blank.**



# 8

## Appendix

### 8.1 List of Initial Values

The initial value refers to the setting value of the product when it was shipped from the factory. If you reset the product in default setting mode, the setting values of the product will change back to the factory default values. The tables below show the initial value of each setting item and the type of reset that changes the value back to the initial value.

#### CAUTION

It is generally not necessary to perform the initialization. Doing so will remove all the customer settings.

#### 8.1.1 Normal Mode

Setting Item	Initial Value	Default (Setting)	Factory (ALL)
ADJUSTMENT MODE			
PITCH POSITION	Varied	No	No
OFFSET POSITION	Varied	No	No
DARKNESS	50	No	No
Buzzer Volume	2	Yes	Yes
LCD Brightness	Midrange	Yes	Yes

#### 8.1.2 User Mode

Setting Item	Initial Value	Default (Setting)	Factory (ALL)
PRINT SPEED	04 IPS	Yes	Yes
PRINT DARKNESS	05	Yes	Yes
PITCH OFFSET	+00 mm	Yes	Yes
PRINT OFFSET	V:+0000 H:+0000	Yes	Yes
ZERO SLASH	YES	Yes	Yes
CHARACTER CODE	JIS	Yes	Yes
KANJI FONTS	GOTHIC	Yes	Yes
CHARACTER PITCH	PROPORTIONAL	Yes	Yes
NOTIFICATION FUNCTION SETTING	NO	-	-
NOTICE FUNCTION	CLEAN PRINTER	Yes	Yes
NOTICE FUNCTION	DISABLE	Yes	Yes

Setting Item	Initial Value	Default (Setting)	Factory (ALL)
CLEAN PRINTER NOTICE DISTANCE	000 m	Yes	Yes
CHANGE ROLLER NOTICE DISTANCE	000 km	Yes	Yes
CHANGE HEAD NOTICE DISTANCE	000 km	Yes	Yes
CHANGE CUTTER NOTICE TIMES	000000	Yes	Yes

### 8.1.3 Interface Mode

Setting Item	Initial Value	Default (Setting)	Factory (ALL)
INTERFACE SETTING	NO	-	-
PORT SELECT	DATA PORT	Yes	Yes
DATA PORT	USB	Yes	Yes
SUB PORT	NONE	Yes	Yes
USB			
PROTOCOL	STATUS4	Yes	Yes
ITEM NO. CHECK	DISABLE (When STATUS5 is selected)	Yes	Yes
BCC CHECK	DISABLE (When STATUS5 is selected)	Yes	Yes
LAN			
DHCP SETTING	DISABLE	-	Yes
RARP SETTING	DISABLE	-	Yes
IPv4 ADDRESS	192.168.001.001	-	Yes
IPv4 SUBNET MASK	255.255.255.000	-	Yes
IPv4 GATEWAY ADR	0.0.0.0	-	Yes
IPv6 RESOLUTION	AUTO	-	Yes
IPv6 ADDRESS	0000:0000:0000:0000: 0000:0000:0000:0000	-	Yes
PREFIX LENGTH	064	-	Yes
DEFAULT ROUTER	0000:0000:0000:0000: 0000:0000:0000:0000	-	Yes
PORT NUMBER1	01024	-	Yes
PORT NUMBER2	01025	-	Yes
PORT NUMBER3	09100	-	Yes
PROTOCOL	STATUS4	Yes	Yes
ITEM NO. CHECK	DISABLE (When STATUS5 is selected)	Yes	Yes
BCC CHECK	DISABLE (When STATUS5 is selected)	Yes	Yes
STATUS REPLY TIMING	ENQ (When STATUS4 is selected)	Yes	Yes

Setting Item	Initial Value	Default (Setting)	Factory (ALL)
<b>RS-232C</b>			
BAUDRATE	19200	Yes	Yes
PARITY BIT	NONE	Yes	Yes
STOP BIT	1 BIT	Yes	Yes
CHARACTER BIT	8 BIT	Yes	Yes
PROTOCOL	STATUS4	Yes	Yes
ITEM NO. CHECK	DISABLE (When STATUS5 is selected)	Yes	Yes
BCC CHECK	DISABLE (When STATUS5 is selected)	Yes	Yes
RECEIVE BUFFER	MULTI (When READY/BUSY, XON/XOFF is selected)	Yes	Yes
<b>IEEE1284</b>			
PROTOCOL	STATUS4	Yes	Yes
ITEM NO. CHECK	DISABLE (When STATUS5 is selected)	Yes	Yes
BCC CHECK	DISABLE (When STATUS5 is selected)	Yes	Yes
RECEIVE BUFFER	MULTI (When STATUS4 is selected)	Yes	Yes
IEEE1284 ACK SIGNAL	00.5us (When 1ITEM is selected)	Yes	Yes
EXTERNAL DEVICE	ENABLE	Yes	Yes
IGNORE CR/LF	NO	Yes	Yes
IGNORE CAN/DLE	NO (When STATUS4 is selected)	Yes	Yes
SNTP FUNCTION	DISABLE	-	Yes
IPv4/6 select	IPv4	-	Yes
NTP IPv4 ADDRESS NTP IPv6 ADDRESS	IPv4: 000.000.000.000 IPv6: 0000:0000:0000:0000: 0000:0000:0000:0000	-	Yes
TIME ZONE	00:00	-	Yes
ERROR NOTICE	DISABLE	-	Yes
SNMP FUNCTION	DISABLE	-	Yes
SNMP SET SELECT	SNMP SETTING	-	-
SNMP SETTING	SNMPv1/v2c[1]	-	-
COMMUNITY NAME	SNMP v1/v2c[1] : public SNMP v1/v2c[2] : NULL	-	Yes
COMMUNITY WRITE	DISABLE	-	Yes
USER NAME	Null	-	Yes
AUTH PROTOCOL	NONE	-	Yes
AUTH KEY	Null	-	Yes
PRIVACY PROTOCOL	NONE	-	Yes

Setting Item	Initial Value	Default (Setting)	Factory (ALL)
<b>SNMP SET SELECT</b>			
<b>SNMP SETTING</b>			
PRIVACY KEY	Null	-	Yes
USER MIB WRITE	DISABLE	-	Yes
<b>TRAP SET</b>			
TRAP TYPE SELECT	SNMPv2c	-	Yes
TRAP	DISABLE	-	Yes
COMMUNITY NAME	Null	-	Yes
USER NAME	Null	-	Yes
AUTH PROTOCOL	NONE	-	Yes
AUTH KEY	Null	-	Yes
PRIVACY PROTOCOL	NONE	-	Yes
PRIVACY KEY	Null	-	Yes
IPv4/6 select	IPv4	-	Yes
TRAP IPv4 ADR	000.000.000.000	-	Yes
TRAP IPv6 ADR	0000:0000:0000:0000: 0000:0000:0000:0000	-	Yes

### 8.1.4 Memory Mode

Setting Item	Initial Value	Default (Setting)	Factory (ALL)
SLOT SETTING	NO	Yes	Yes
CARD SLOT SELECT SLOT0	RAM	Yes	Yes
CARD SLOT SELECT SLOT1	FROM	Yes	Yes
CARD SLOT SELECT SLOT2	SD	Yes	Yes
MEMORY MODE	MEMORY SIZE	-	-
STORED CONTENTS	FORM OVERLAY	-	-
MEMORY FORMAT	NO	-	-
FORMAT START	NO	-	-

## 8.1.5 Advanced Mode

Setting Item	Initial Value	Default (Setting)	Factory (ALL)
DARKNESS RANGE	A	Yes	Yes
PRINTER TYPE AUTO SETTING	ENABLE	Yes	Yes
PRINTER TYPE	TEAR OFF/ CUTTER (When cutter unit is installed)	Yes	Yes
EJECT CUT MOTION	DISABLE	Yes	Yes
BACKFEED MOTION	BEFORE	Yes	Yes
PRINT METHOD	TRANSFER	Yes	Yes
PITCH SENSOR	ENABLE (When CONTINUOUS or CUTTER is selected)	Yes	Yes
SENSOR TYPE	GAP	Yes	Yes
CHECK MEDIA SIZE	DISABLE	Yes	Yes
COMMAND ERROR	DISABLE	Yes	Yes
HEAD CHECK	DISABLE	Yes	Yes
HEAD CHECK	NORMAL (When HEAD CHECK is enabled)	Yes	Yes
HEAD CHECK MODE	ALL (When HEAD CHECK is enabled)	Yes	Yes
HEAD CHECK PAGE NO.	000001 (When CHECK PAGE is selected)	Yes	Yes
EXTERNAL SIGNAL	DISABLE	Yes	Yes
EXTERNAL SIGNAL	TYPE4	Yes	Yes
EXTERNAL REPRINT	DISABLE	Yes	Yes
SET CALENDAR	NO	-	-
CALENDAR	11/01/01 00:00	No	Yes
CALENDAR INPUT	11/01/01 00:00	No	Yes
CALENDAR CHECK	ENABLE	Yes	Yes
AUTO ONLINE	YES	Yes	Yes
AUTO ONLINE FEED	NO	Yes	Yes
FEED ON ERROR	YES	Yes	Yes
SELECT LANGUAGE	ENGLISH	Yes	Yes
EURO CODE	D5	-	Yes
PROTOCOL CODE	STANDARD	Yes	Yes
LCD POWER SAVING	00 MIN	Yes	Yes
ERROR INDICATION	NONE	Yes	Yes

### 8.1.6 Hex Dump Mode

Setting Item	Initial Value	Default (Setting)	Factory (ALL)
SELECT DUMP DATA	RECEIVE DATA	-	-

### 8.1.7 Test Print Mode

Setting Item	Initial Value	Default (Setting)	Factory (ALL)
TEST PRINT MODE	CONFIGURATION	-	-
TEST PRINT SIZE	26 cm (When CONFIGURATION, BARCODE, HEAD CHECK is selected)	-	-
	LARGE (When FACTORY is selected)	-	-
PITCH POSITION	+0.00mm	No	No
OFFSET POSITION	+0.00mm	No	No
DARKNESS	50	Yes	No

### 8.1.8 Default Setting Mode

Setting Item	Initial Value	Default (Setting)	Factory (ALL)
DEFAULT MODE	PRINTER SETTING	-	-
DEFAULT PRINTER SETTING	NO	-	-
DEFAULT ALT.PROTOCOL	NO	-	-

## 8.2 Download and Upload Specification

The following table shows the download and upload specification using the interface and memory card.

	Target item	SD card/ USB memory	Interface	Remarks
Program download	Firmware	O	O	
	Kanji outline font	O	O	
	Kanji font	O	O	
	Configuration (settings)	O	O	
	Font/logo	O	O	Files that are uploaded in the upload mode are downloaded.
	TTF	O	O	Files that are uploaded in the upload mode are downloaded.
	Receive buffer	X	X	
	STATUS5 log	X	X	
	All	O	X	All the items with "O" above are downloaded.
Program upload	Firmware	O	X	
	Kanji outline font	O	X	
	Kanji font	O	X	For NEC font, upload is not available.
	User mode information	O	X	When "All" is selected, both binary format and text format files are uploaded. (Normally text format file only)
	Font/logo	O	X	
	TTF	O	X	
	Receive buffer	X	X	It is possible to upload in the receive data save mode.
	STATUS5 log	O	X	
	All	O	X	All the items with "O" above are downloaded.

### Note about downloading

- If the file does not exist when selecting the item to be downloaded, that item cannot be selected.
- The font size of "Configuration" and "Font/logo" are different depending on the head density. Do not download anything between the products with different head density.
- The download file for "Kanji font" varies depending on Chinese/Japanese font.
- For "Configuration", the items listed in the default list will be downloaded (excluding Life Counter, Head Counter, Cut Counter, MAC Address, BD Address, Main PCB REV, PLD VERSION and PCB Number).

### Note about uploading

- When the same file already exists in the save location, the existing file is overwritten.
- An error is raised when the folder to be uploaded cannot be found. Format the card in the Memory mode before uploading.
- Write protected SD card or USB memory will cause an error when uploading. Release the write protection from them before uploading.
- Not having enough available memory in SD card or USB memory will cause an error when uploading.
- The date of file creation is according to the calendar if the real-time clock (calendar) kit is installed. If not, the file creation date will be indicated by the firmware release date.
- For "Configuration", the current contents of the items listed in the default list will be uploaded.

## 8.3 Memory Storage Folder Structure

SD cards or USB memories are used when downloading or uploading data (graphic data or external characters) and the firmware from or to the product. The following folder structure of the memory storage shows the folders name and files name that are saved (read) when uploading (downloading).

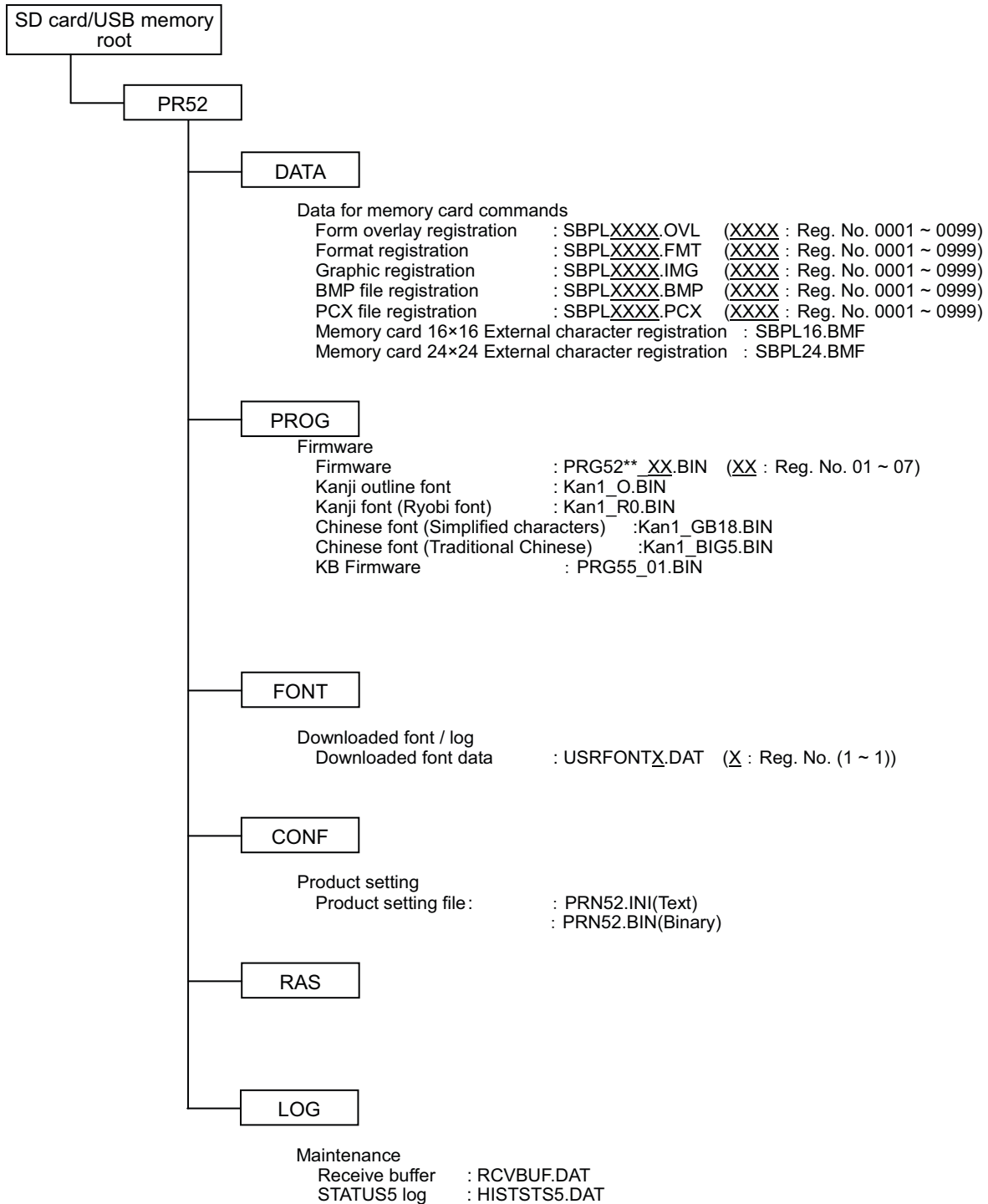



**Note**

- The folders under the [PR52] are created by formatting the memory card in the Memory mode.
- Make sure to format the memory card in the Memory mode. Refer to [Section 4.2.7 Memory Mode](#) for details.

Formatting the memory card via Windows may result in data save failure or data reference failure.

- Do not change the file names and folder names under the [PR52] folder.
  - Do not save files other than released (or uploaded) firmware or fonts in the [PROG] and [FONT] folder. Doing so, the behavior of downloading or after downloading may be incorrect.
  - Do not remove the memory card while the product is accessing to it. Doing so may damage or lose the data in the memory card.
  - When saving the data to the memory card by using the registration SBPL commands, the date of file creation is according to the calendar if the real-time clock (calendar) kit is installed. If the real-time clock (calendar) kit is not installed, the file creation date will be indicated by the firmware release date.
  - Make sure that the product is powered off before inserting or removing the memory card. Otherwise the product may not read or write the data properly.
-

## 8.4 Notification Function

This section shows the media motion when the set notification interval has been reached. You can set the notification function in the **NOTIFICATION FUNCTION SETTING** screen of the user mode menu.

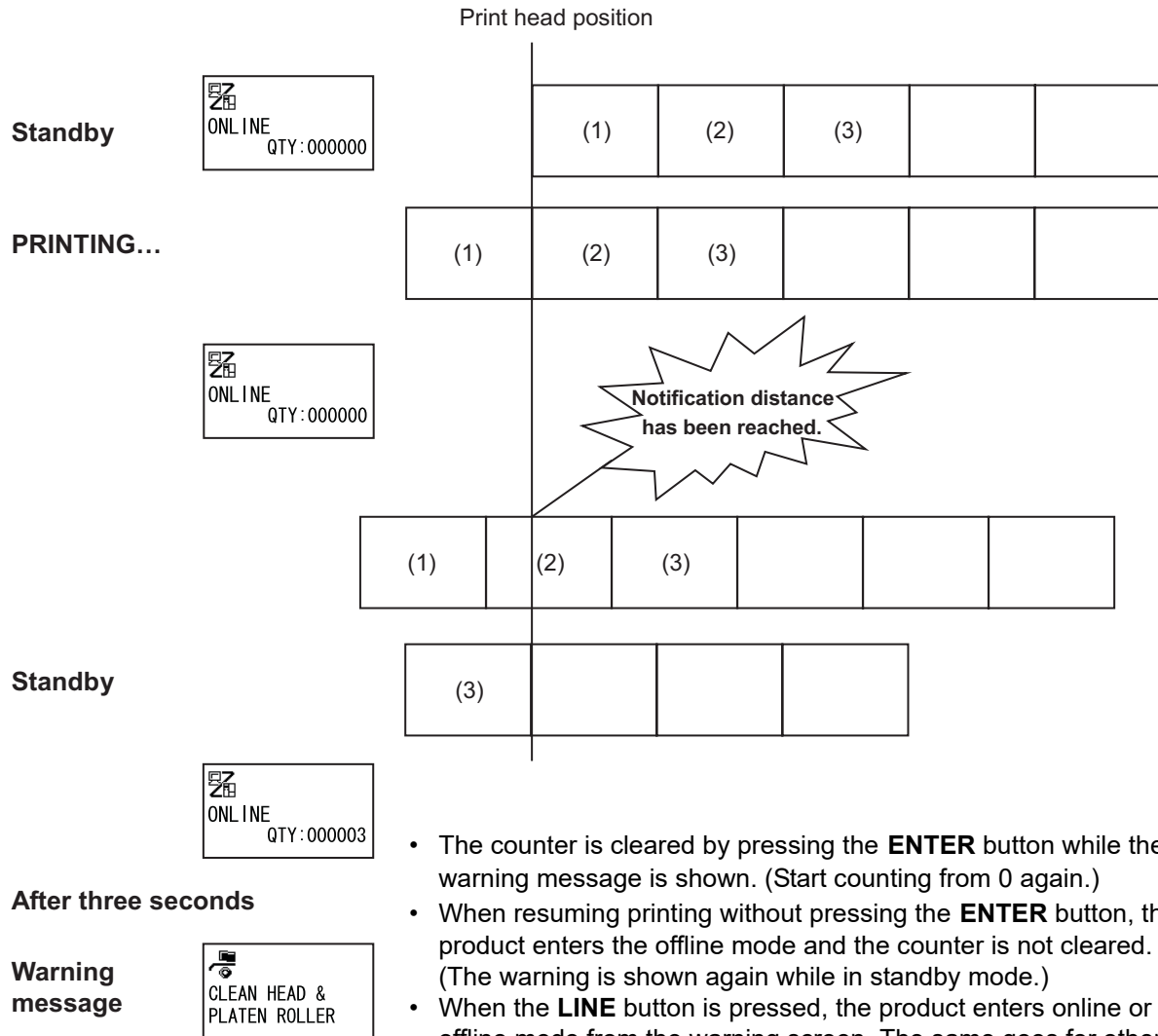

- The counter is cleared by pressing the **ENTER** button while the warning message is shown. (Start counting from 0 again.)
- When resuming printing without pressing the **ENTER** button, the product enters the offline mode and the counter is not cleared. (The warning is shown again while in standby mode.)
- When the **LINE** button is pressed, the product enters online or offline mode from the warning screen. The same goes for other buttons, entering each screen.

### When multiple notifications occur at the same time

The warning screen can be changed by pressing the  $\triangle/\nabla$  buttons.

To release the warning, press the **ENTER** button at each screen.

When the warning is released by pressing the **ENTER** button, the warning screen is deleted and the product goes to the next screen.



Press the  $\triangle/\nabla$  buttons.



Press the  $\triangle/\nabla$  buttons.



## 8.5 Media Sensor Positions and Option Positions

The media sensor positions and various operation mode (option) positions are as follows:

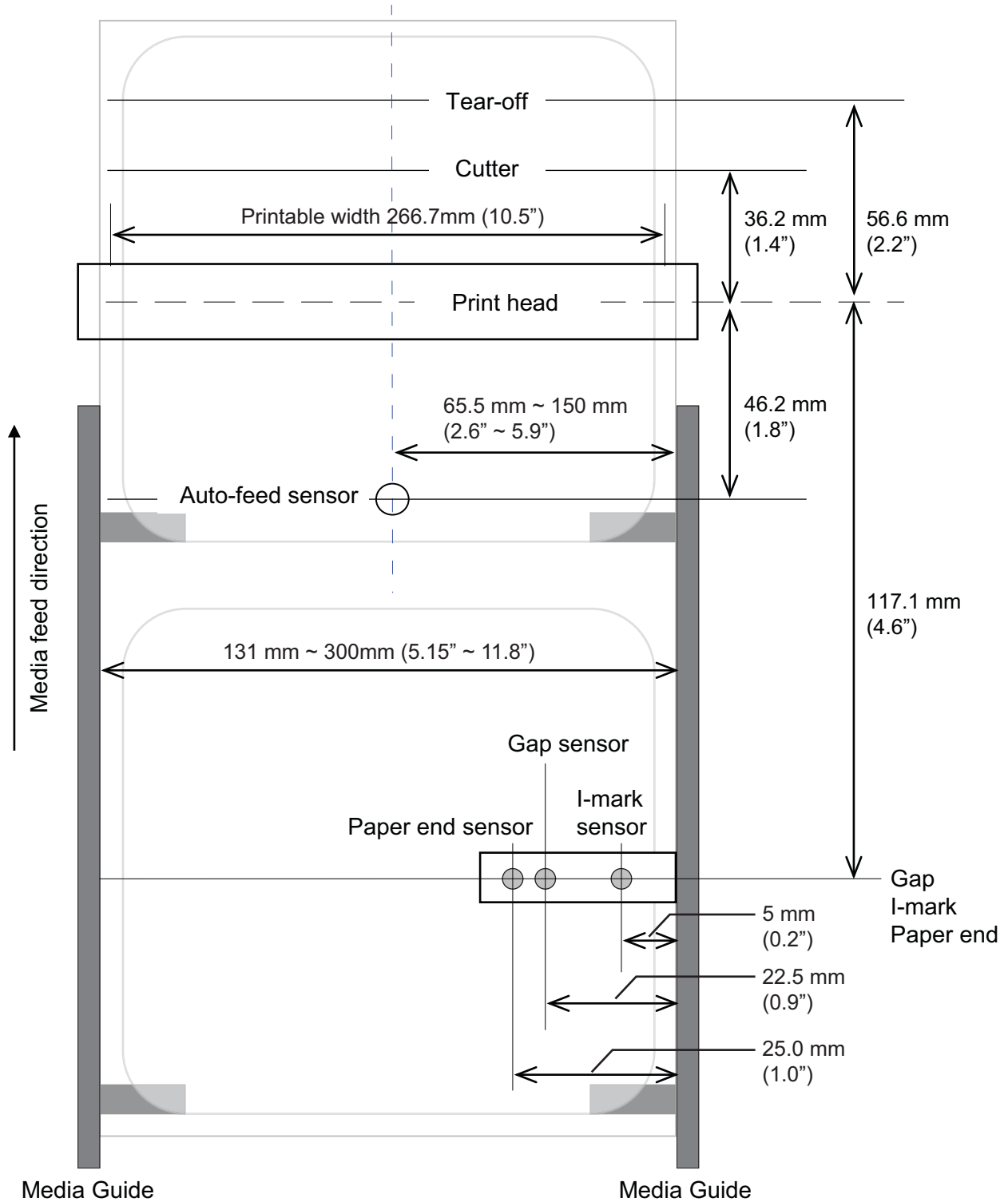

## 8.6 Paper End and Ribbon End Detection

### 8.6.1 Paper End

#### Paper End Detection in Feed Operation

After the paper end is detected, the product stops the feed operation immediately and generates an error.

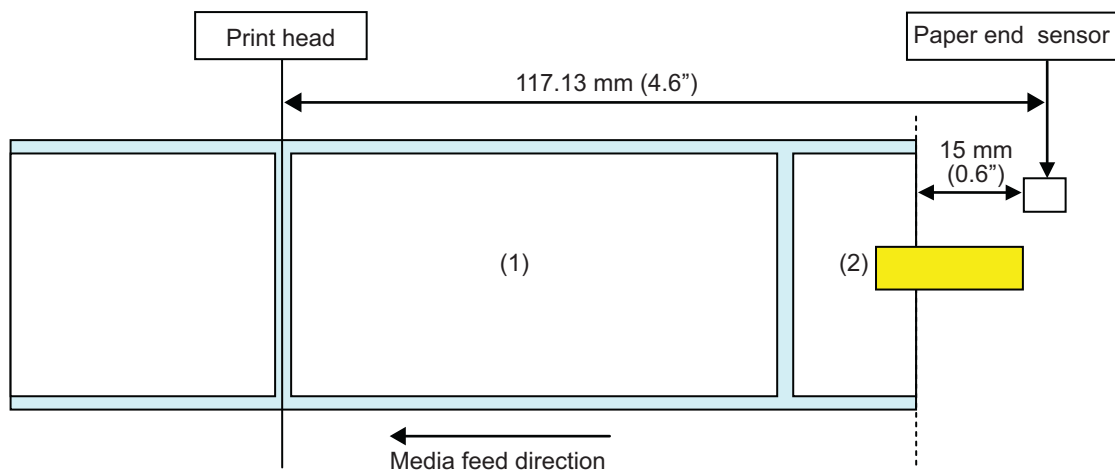

- Paper end sensor detects the absence of media and sends a paper end error message at the position after the media is fed 15mm (0.6”).

#### Paper End Detection in Print Motion

Operation varies by the number of remaining print steps when the paper end occurs during print operation.

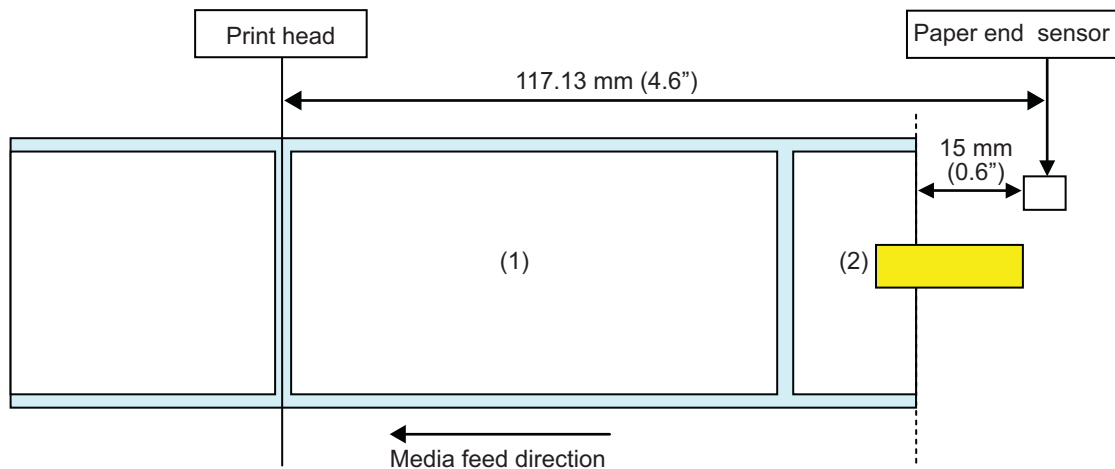

[When the print content falls within the area from the print head position to 15 mm (0.6") less than the label end sensor.]

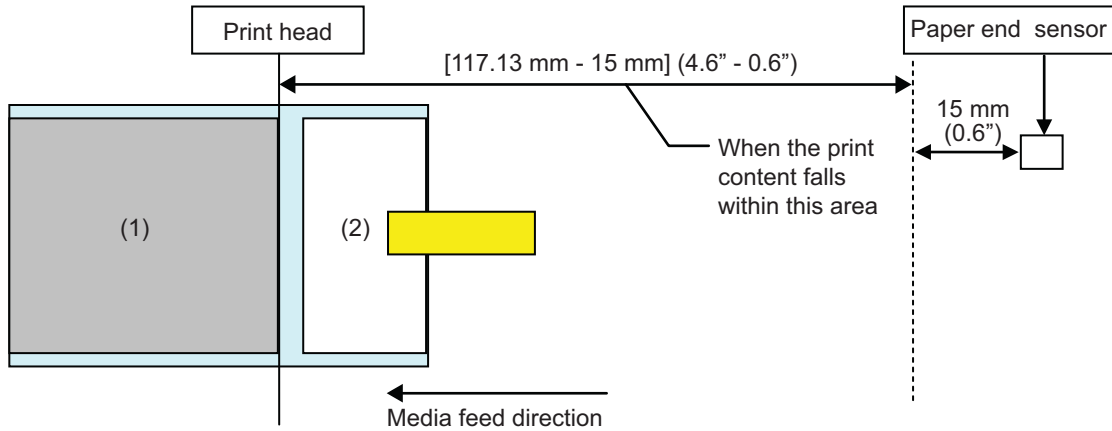

- After completing the print of media (1), "Paper end error" will occur.
- After releasing the error, media (1) will not be printed again.

[When the media pitch size is between the print head position and the paper end sensor, and is more than  $[117.13 \text{ mm} - 15 \text{ mm}] (4.6'' - 0.6'')$ .]

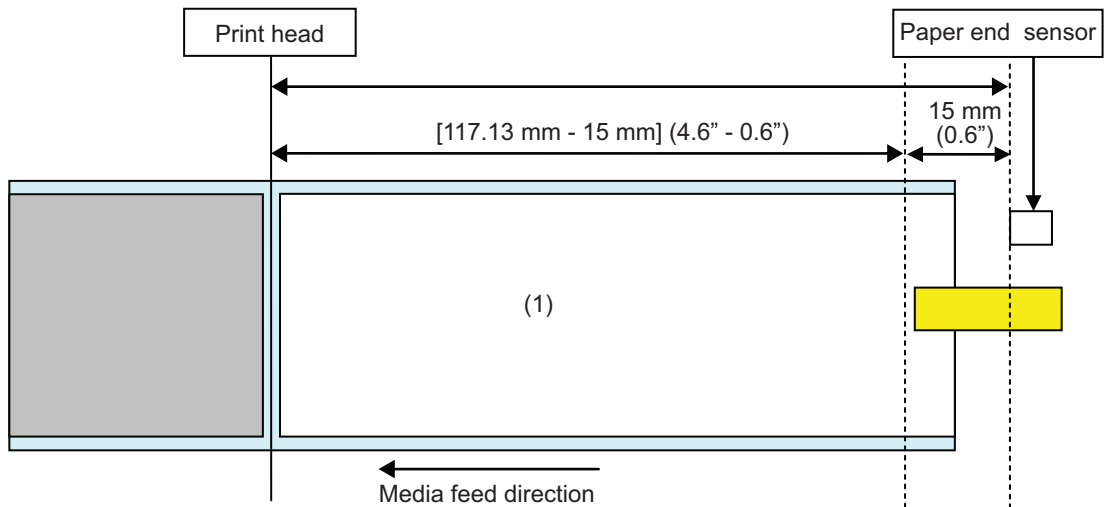

- "Paper end error" will occur while printing the media (1), right after detecting "paper end".
- If an error occurs while printing, media (1) will be printed again after releasing the error. If the print job is completed at the time an error occurs, media (1) will not be printed again.

## 8.6.2 Ribbon End

### **Ribbon end detection**

The ribbon sensor on the ribbon supply side detects the ribbon end error.

While feeding the media, when the ribbon on the ribbon supply side has not rotated for 15 mm (0.6") or more, the ribbon sensor will detect the ribbon end error.

### **Ribbon near end detection**

The ribbon near end is detected by the ribbon sensor, from the rotation speed of the supply side ribbon. This occurs when the remaining ribbon length becomes less than approximately 15 m, 49.2 ft. (ribbon diameter is approximately 36 mm, 1.4").

Note that the remaining ribbon length (15 m, 49.2 ft.) is a calculated value from the revolution speed of the ribbon on the supply side. The timing of the ribbon end varies according to the reading condition of the ribbon sensor and the ribbon thickness.

## 8.7 Print Operation

The following print operations are selectable by setting in the advanced mode and using SBPL commands.

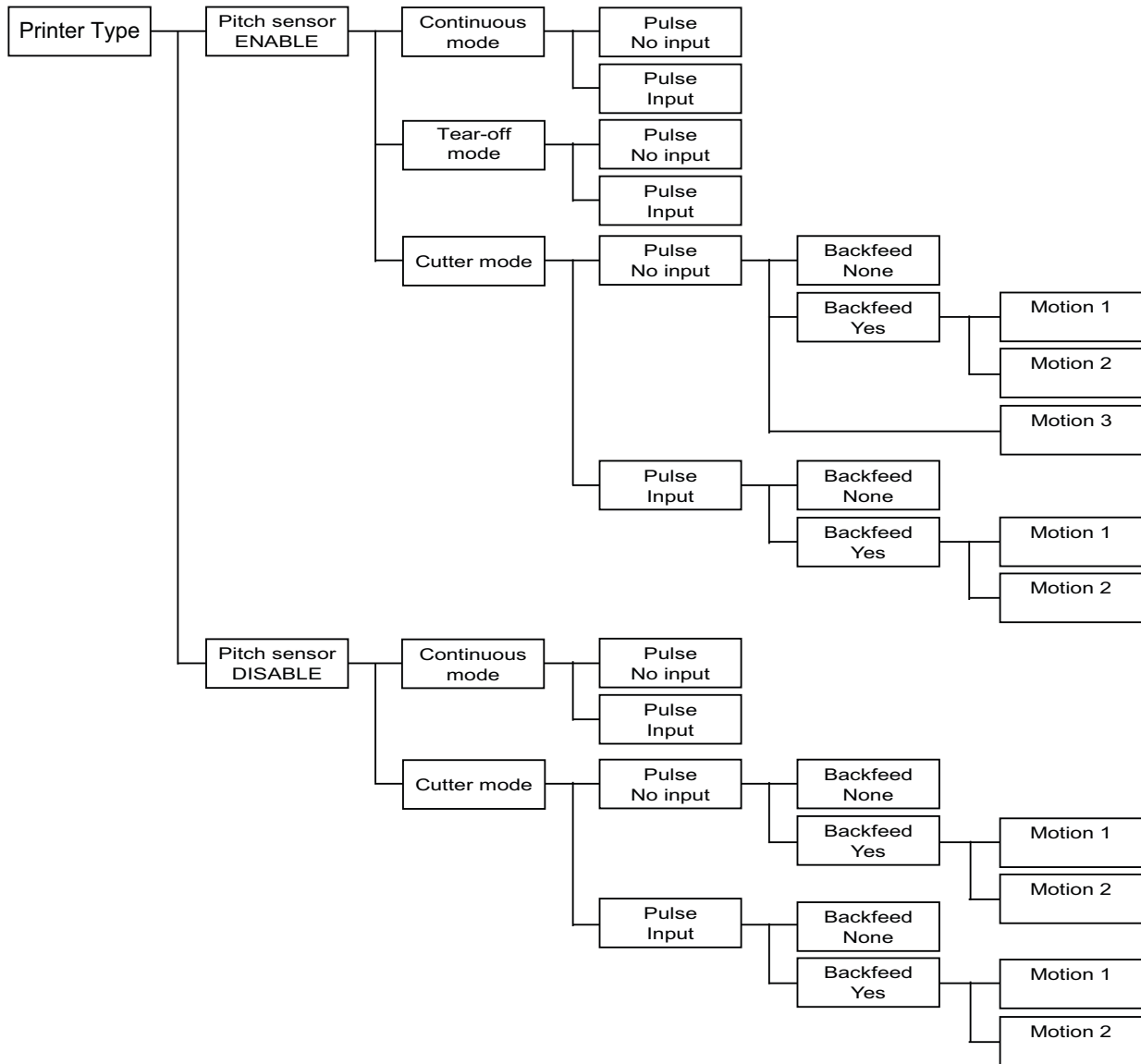

Motion 1: Backfeed after printing  
 Motion 2: Backfeed before printing  
 Motion 3: Cut & Print



## 8.7.1 Continuous Mode, Pitch Sensor Enabled and No Pulse Input (Head Check Disabled)

### (1) Operation

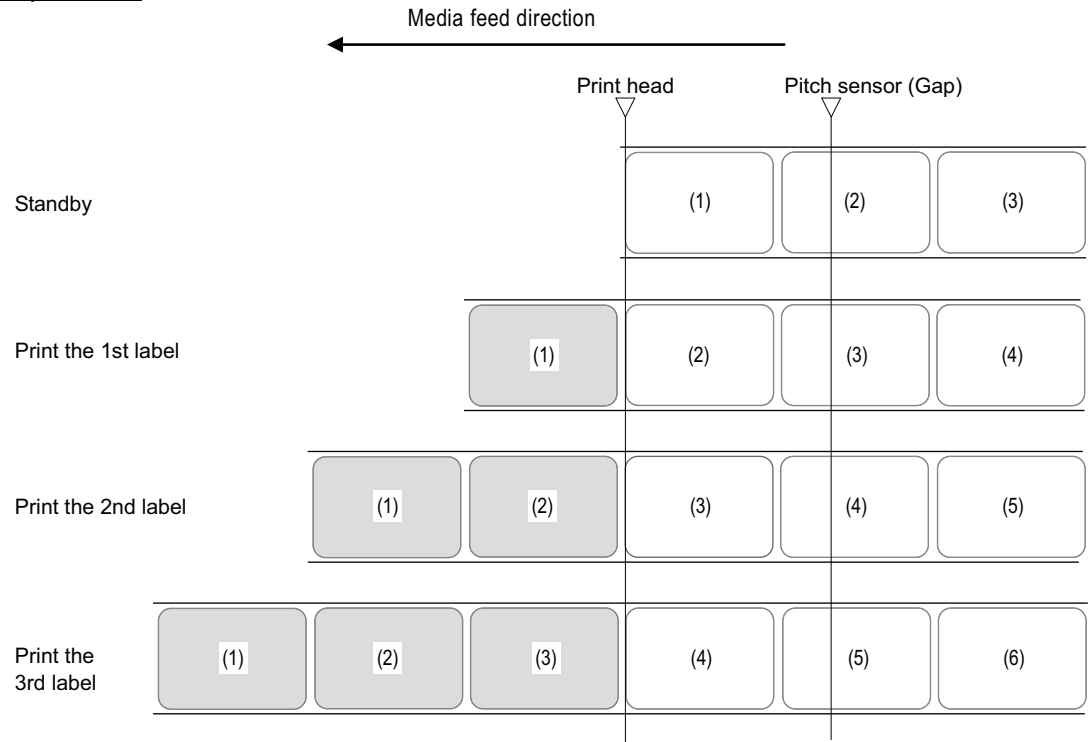

(Note)  
The positions shown above are the base reference point when using the Gap sensor.

### (2) Timing chart

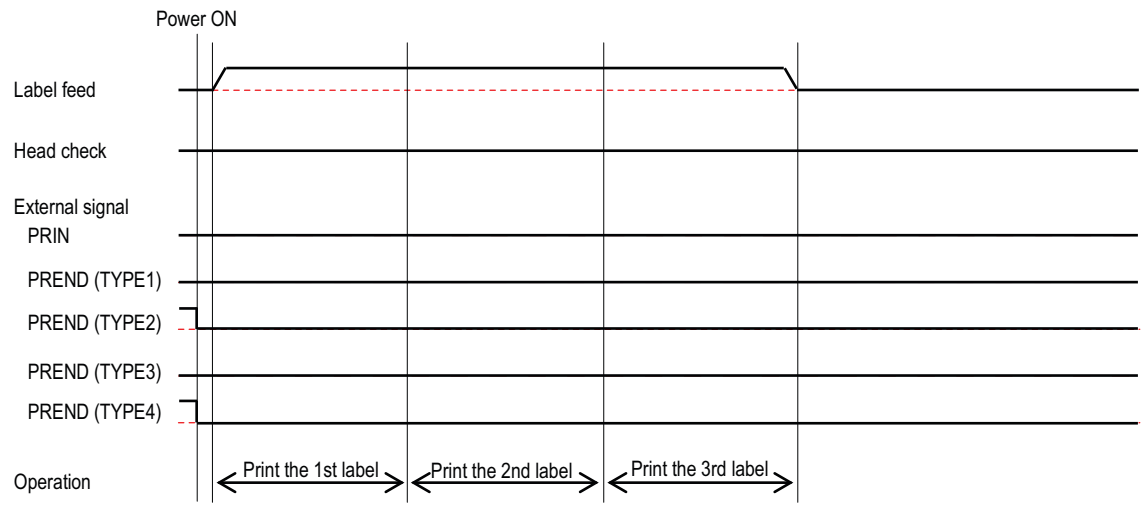

## 8.7.2 Continuous Mode, Pitch Sensor Enabled and No Pulse Input (Head Check Enabled)

### (1) Operation

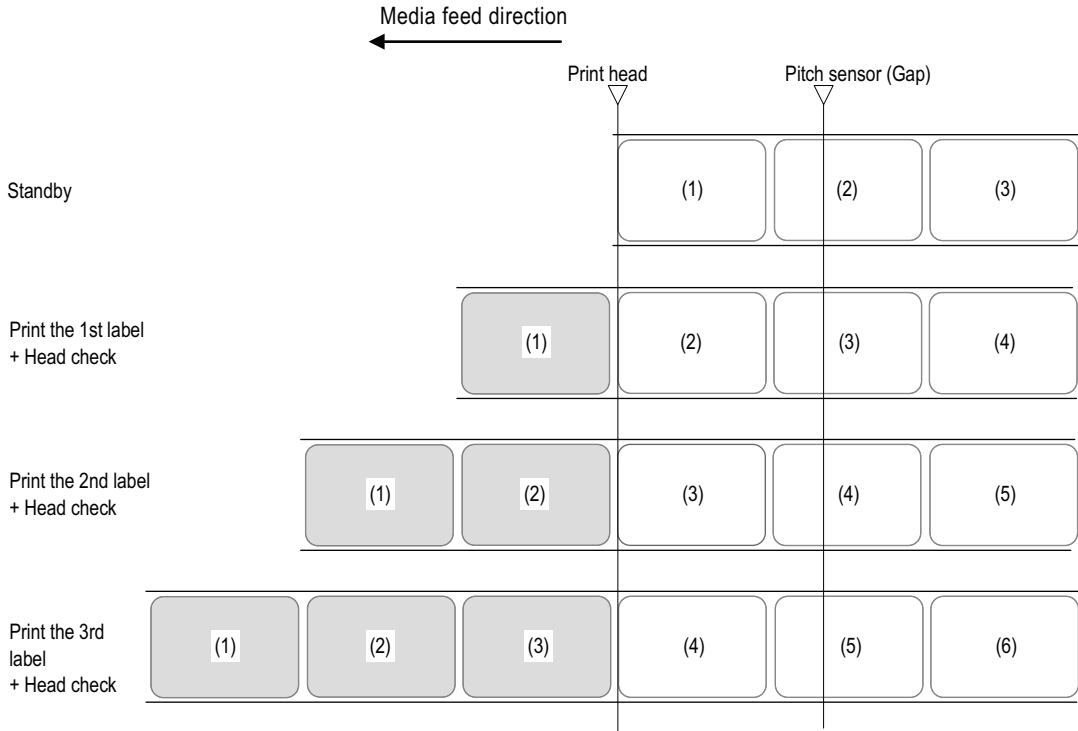

Note  
The positions shown above are the base reference point when using the Gap sensor.

### (2) Timing chart

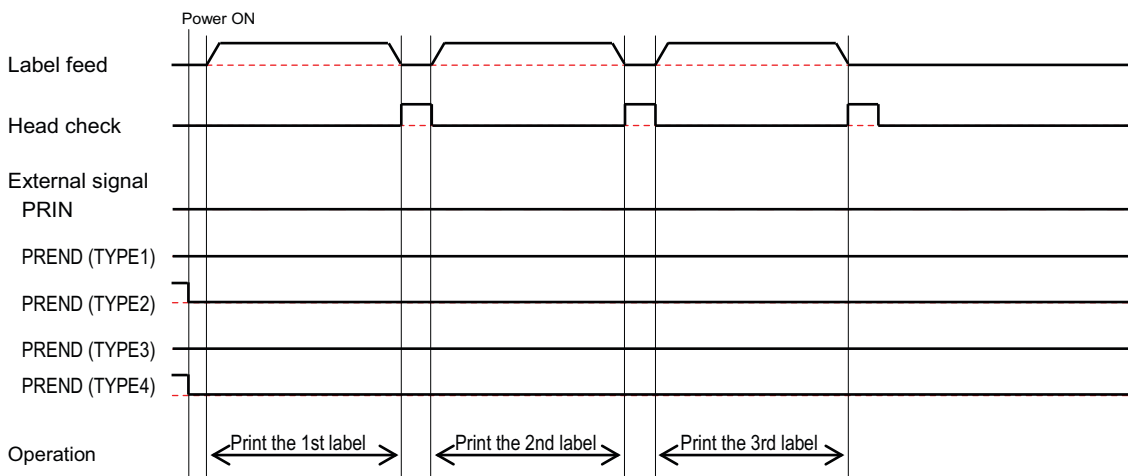

### 8.7.3 Continuous Mode, Pitch Sensor Enabled and Pulse Input (Head Check Disabled)

(1) Operation

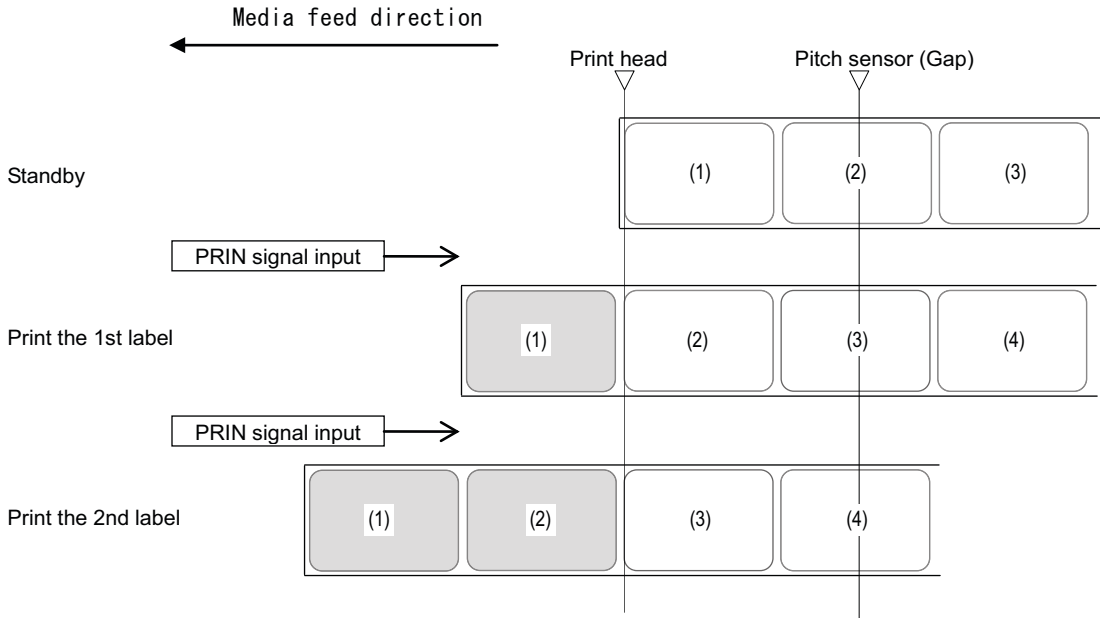

(Note)  
The positions shown above are the base reference point when using the Gap sensor.

(2) Timing chart

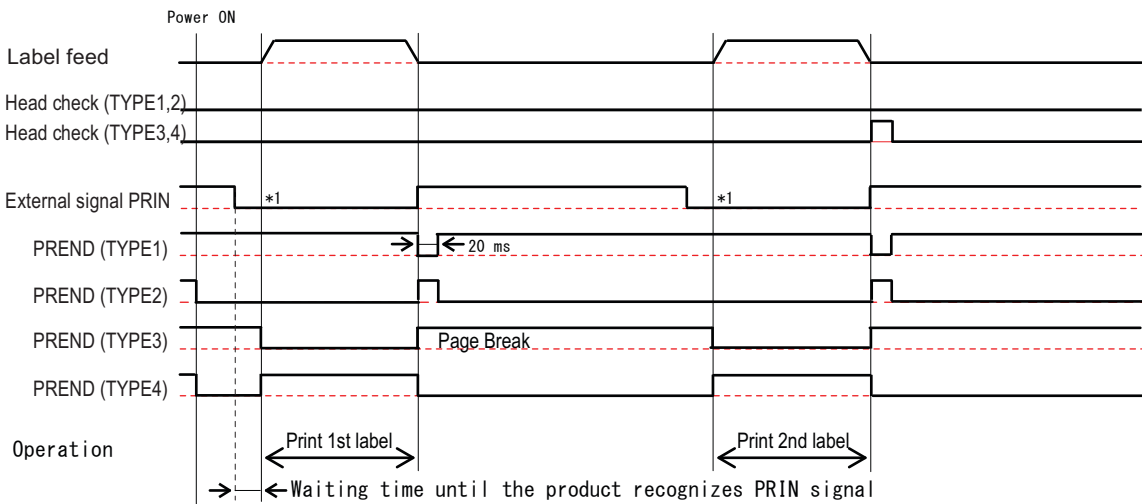

\*1. Maintain PRIN signal until PREND signal is output.

## 8.7.4 Continuous Mode, Pitch Sensor Enabled and Pulse Input (Head Check Enabled)

### (1) Operation

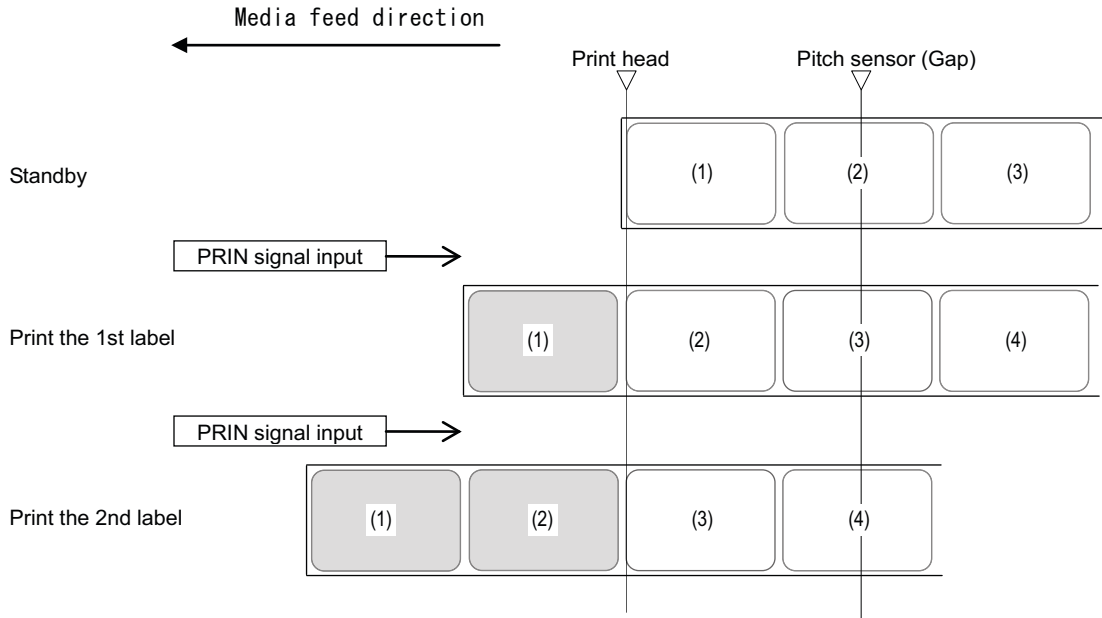

(Note)  
The positions shown above are the base reference point when using the Gap sensor.

### (2) Timing chart

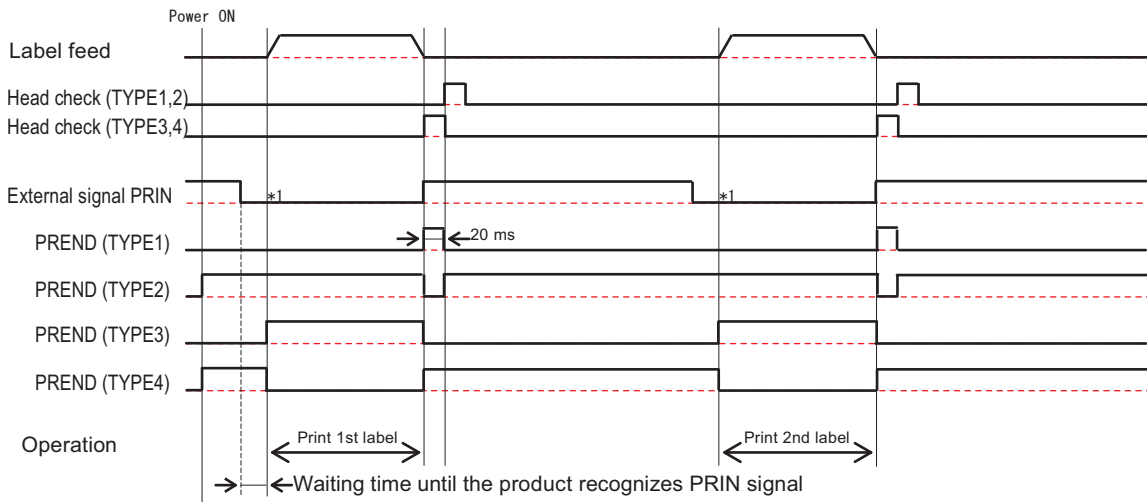

\*1. Maintain PRIN signal until PREND signal is output.

## 8.7.5 No Pulse Input in Tear-off Mode (Head Check Disabled)

### (1) Operation

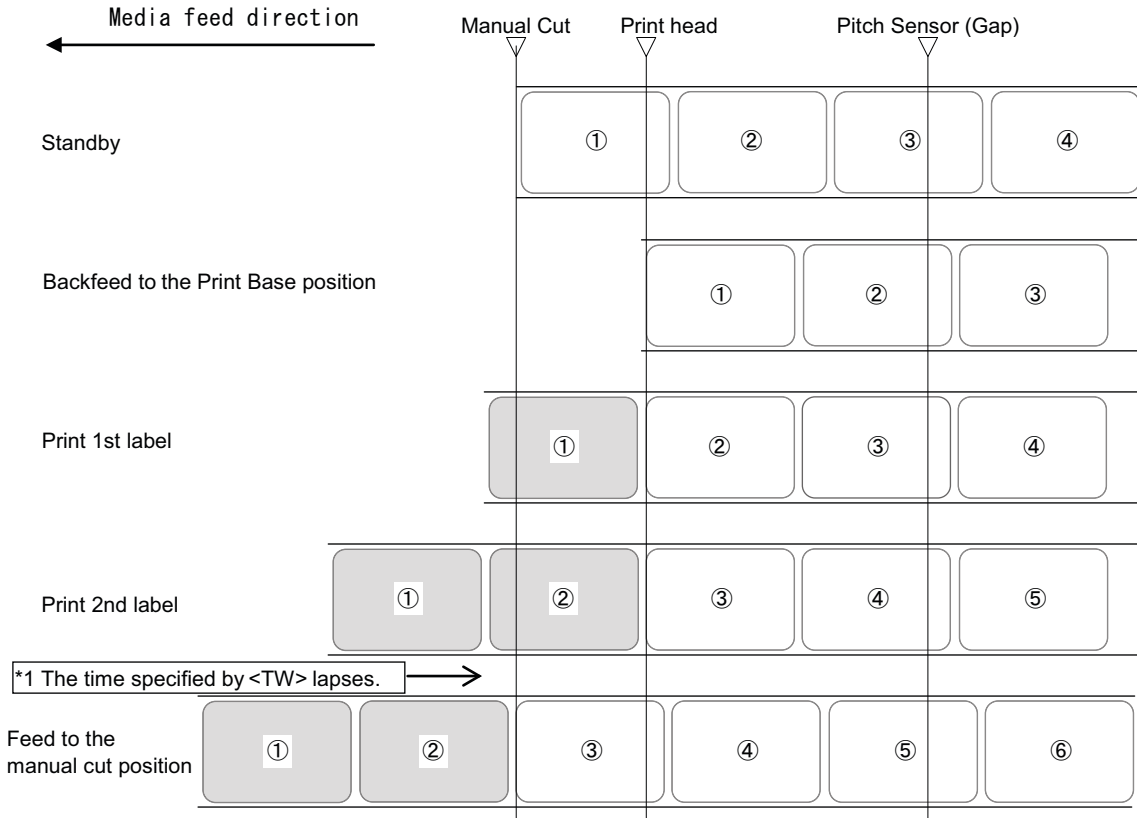

\*1 The media is fed to the manual cut position when time (option unit stand-by time; default value - 1000ms) specified by <TW> lapses and no print job is sent.

(Note)

- The base position using the Gap sensor is shown above.

### (2) Timing chart

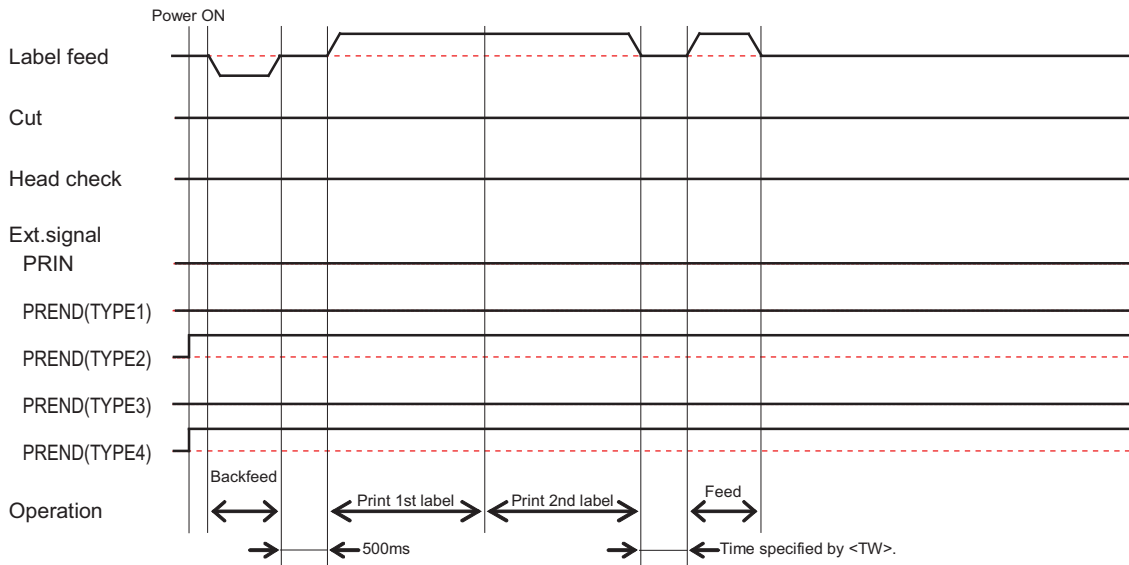

## 8.7.6 No Pulse Input in Tear-off Mode (Head Check Enabled)

### (1) Operation

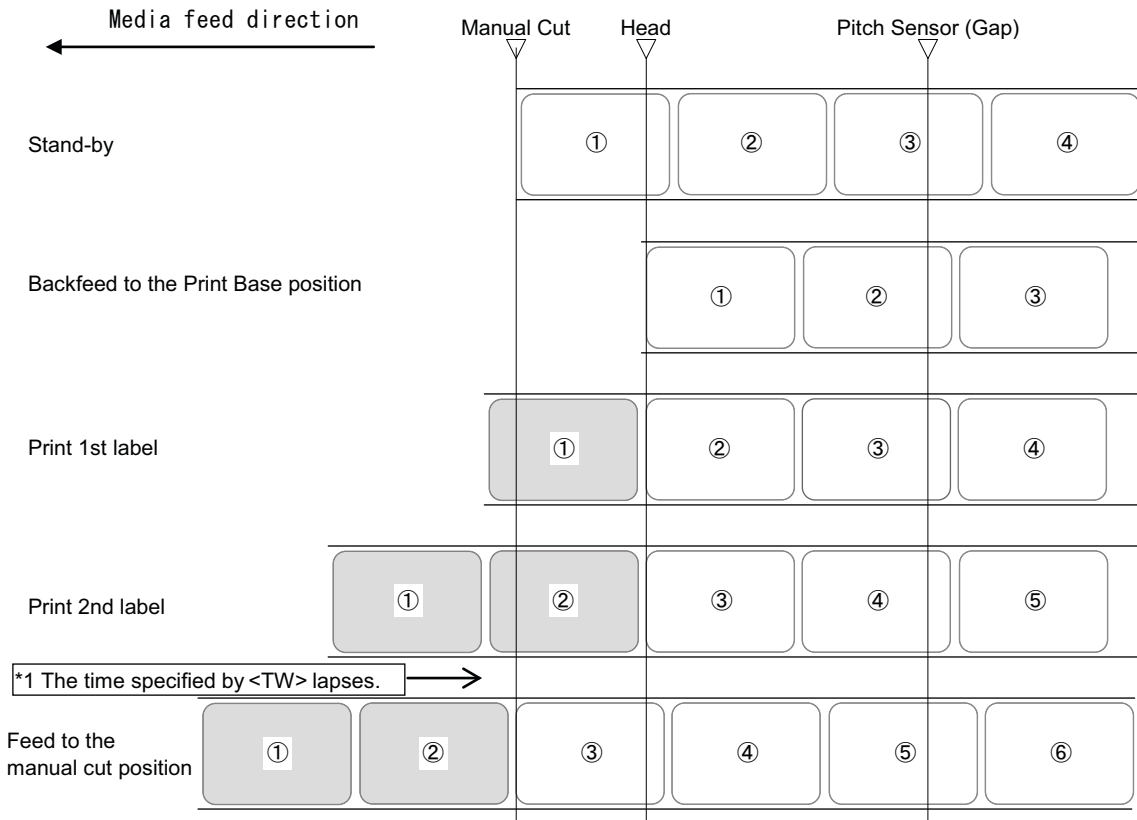

\*1 The media is fed to the manual cut position when time (option unit stand-by time; default value - 1000ms) specified by <TW> lapses and no print job is sent.

(Note)

- The base position using the Gap sensor is shown above.

### (2) Timing chart

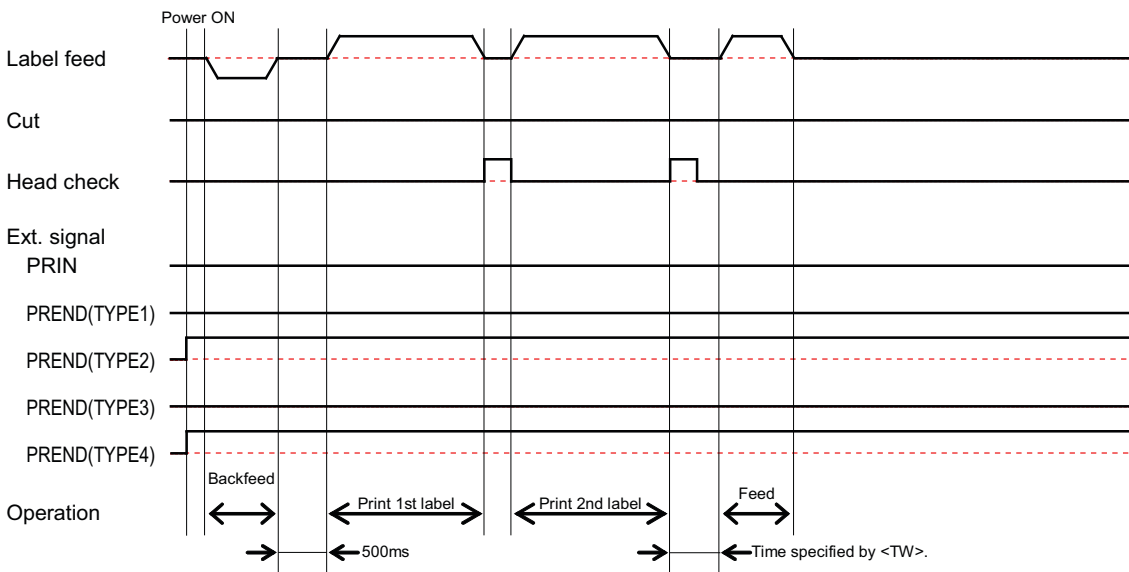

## 8.7.7 With Pulse Input in Tear-off Mode (Head Check Disabled)

### (1) Operation

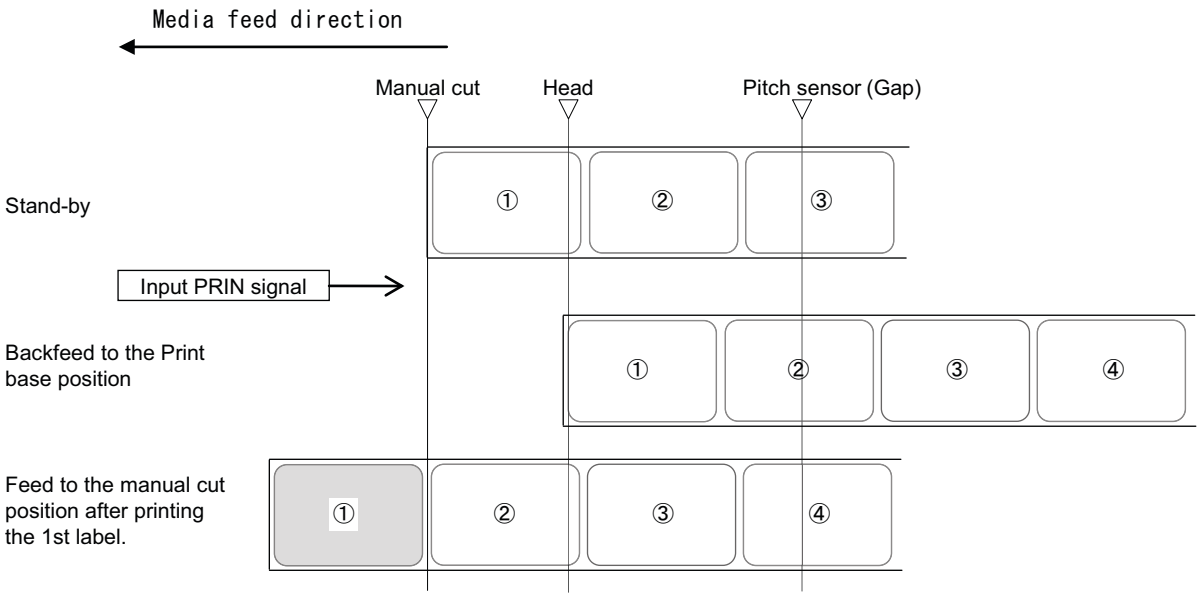

(Note)  
 • The base position using the Gap sensor is shown above.

### (2) Timing chart

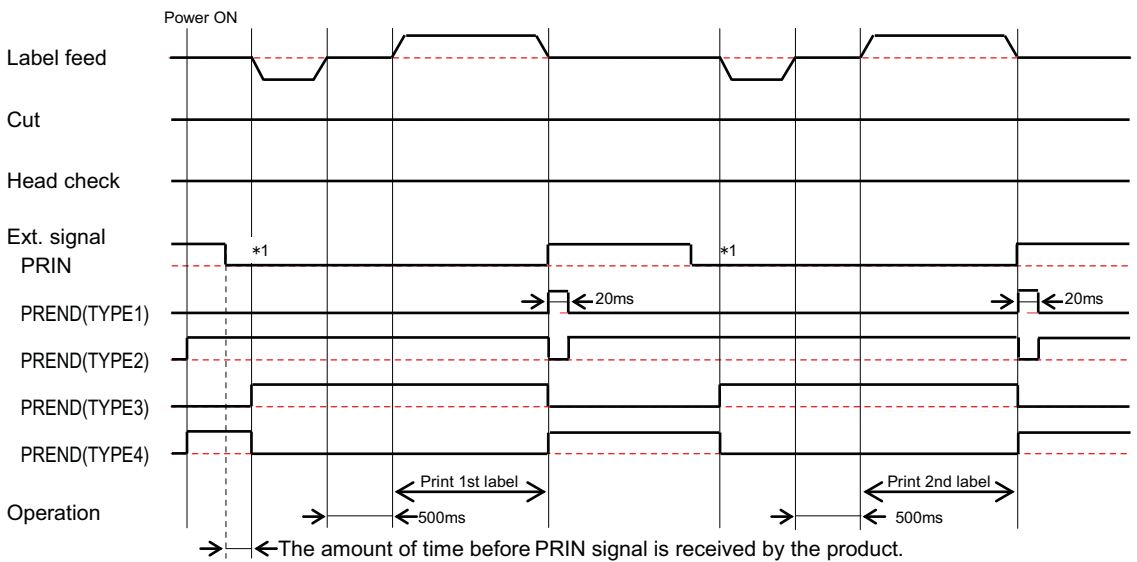

\*1. Retain PRIN until PREND is output.

## 8.7.8 With Pulse Input in Tear-off Mode (Head Check Enabled)

### (1) Operation

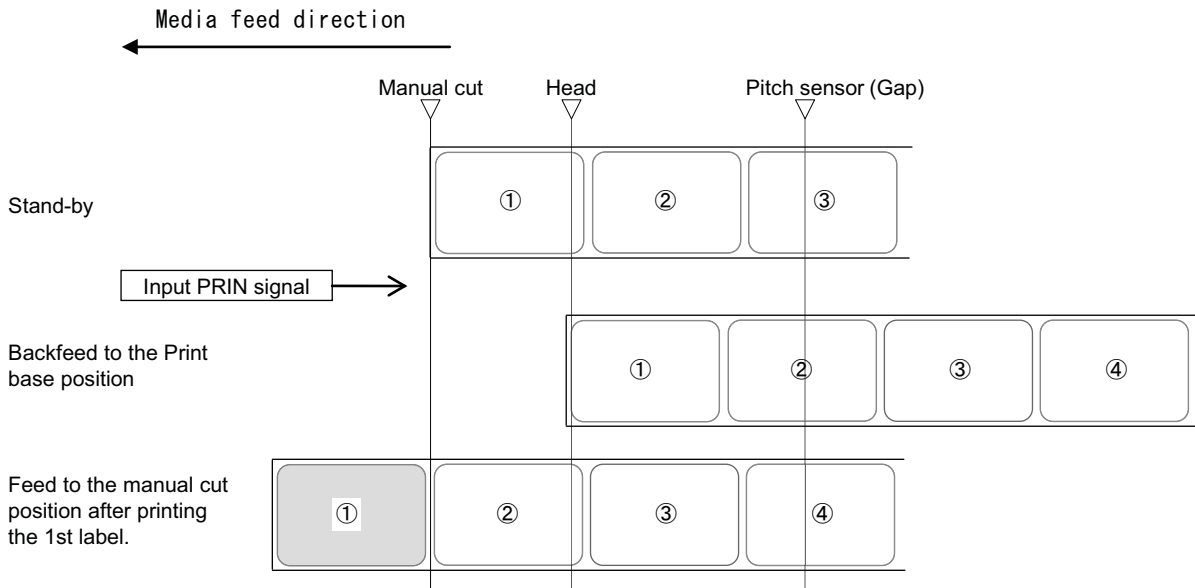

(Note)

- The base position using the Gap sensor is shown above.

### (2) Timing chart

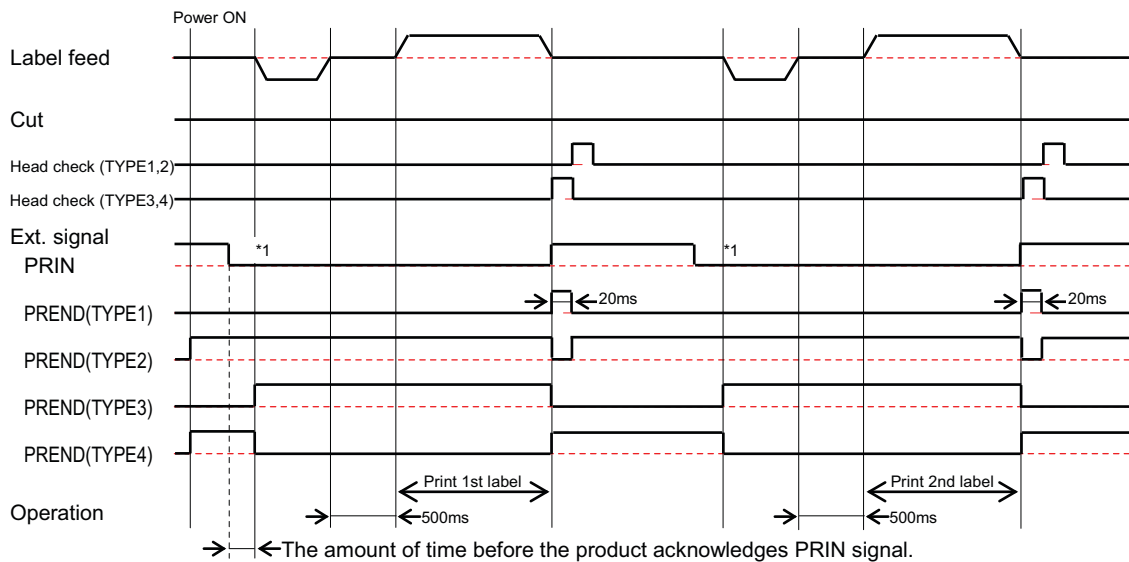

\*1. Retain PRIN until PREND is output.



## 8.7.9 No Backfeed/Pulse Input in Cutter Mode

### (1) Operation

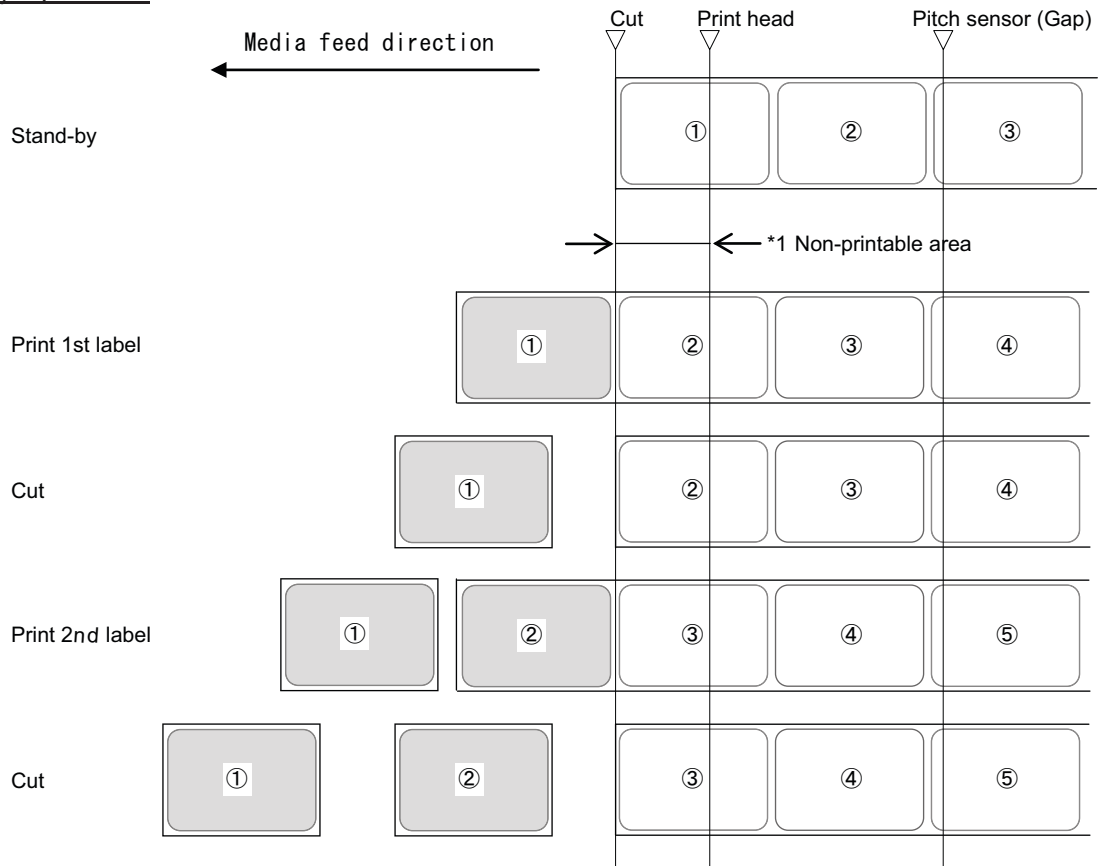

\*1 Take note that there are some non-printable areas, as no backfeed is performed.

(Note)

- The base position using the Gap sensor is shown above.

### (2) Timing chart

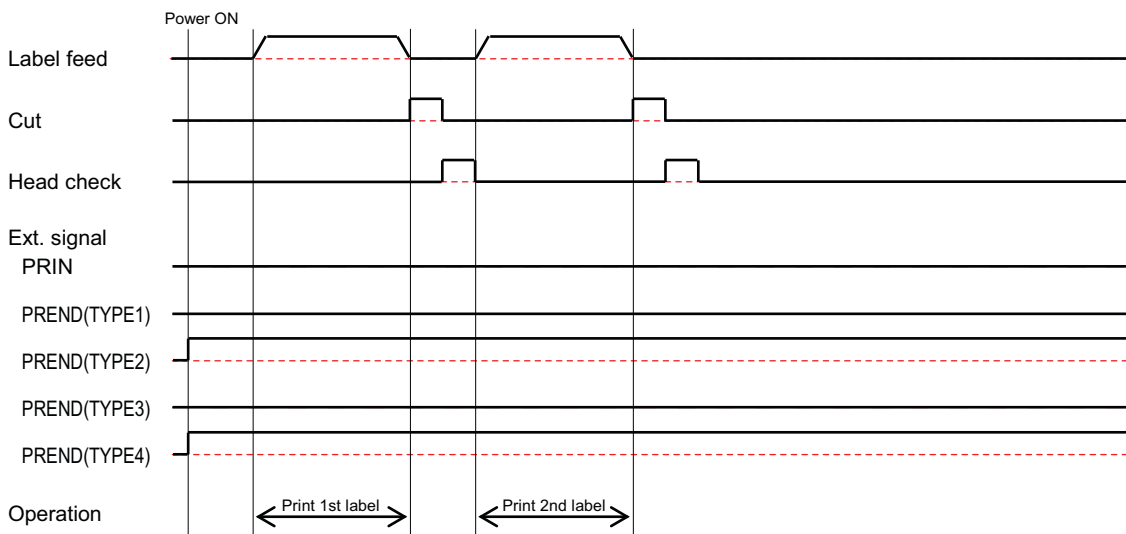

## 8.7.10 No Pulse Input in Motion 1 Cutter Mode

### (1) Operation

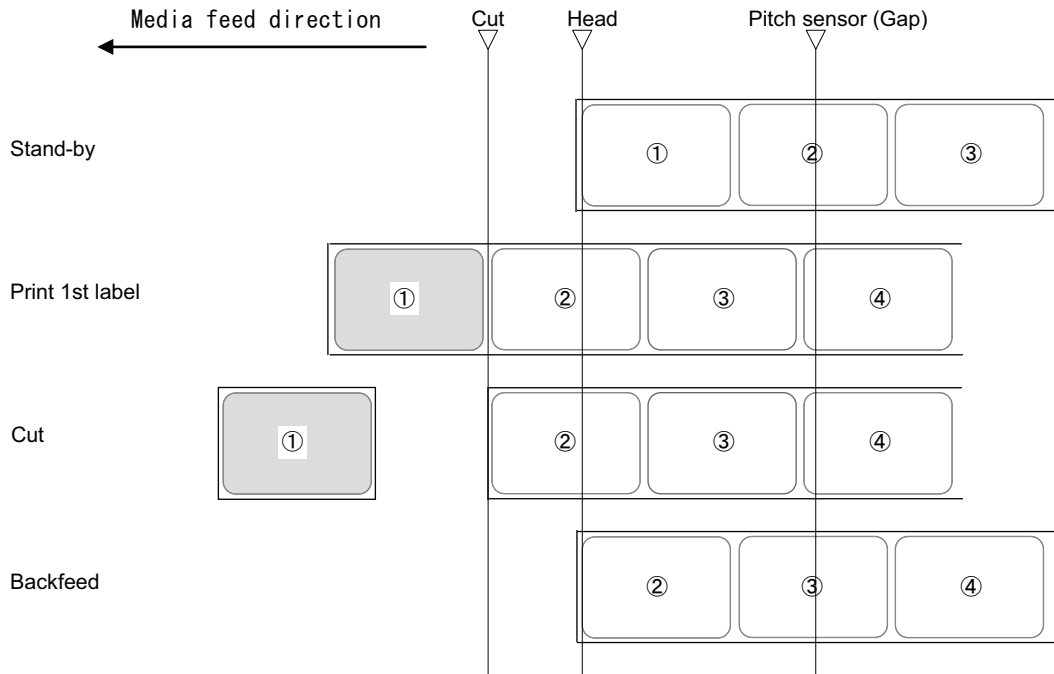

(Note)  
 • The base position using the Gap sensor is shown above.

### (2) Timing chart

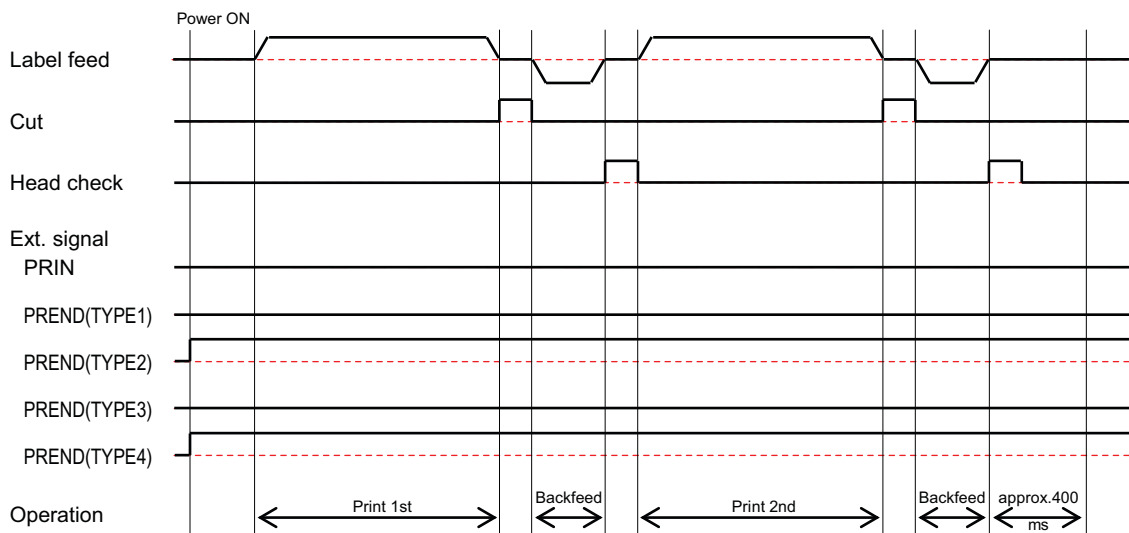

## 8.7.11 No Pulse Input in Motion 2 Cutter Mode

### (1) Operation

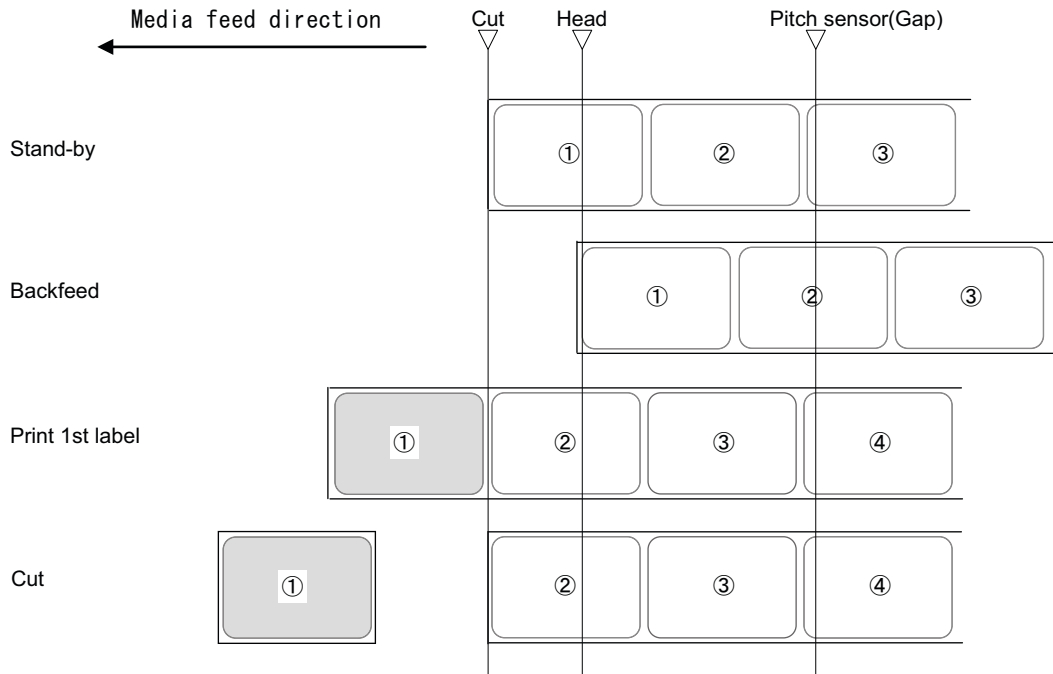

(Note)

- The base position using the Gap sensor is shown above.

### (2) Timing chart

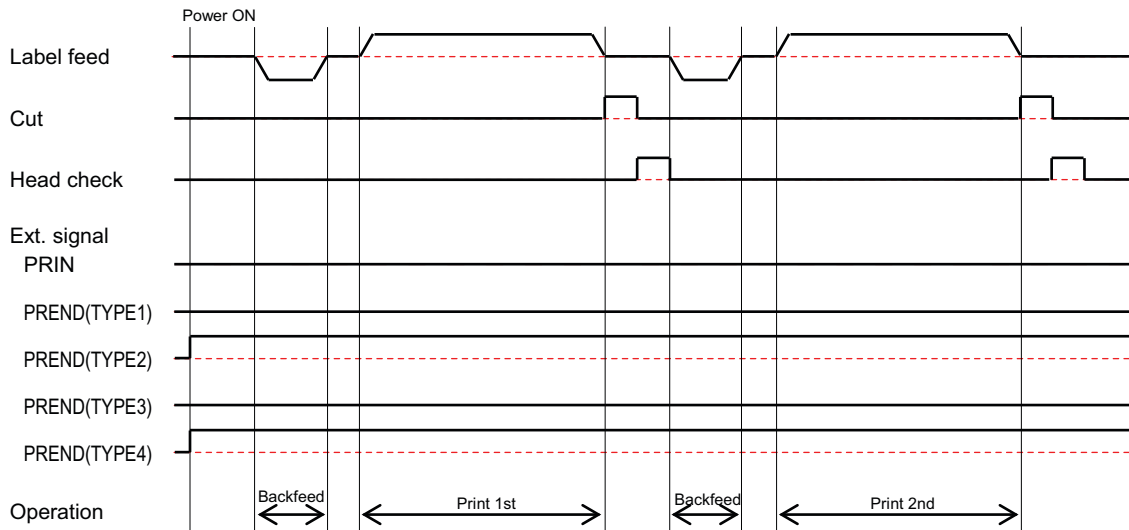

### 8.7.12 No Pulse Input in Motion 3 Cutter Mode (Head Check Disabled)

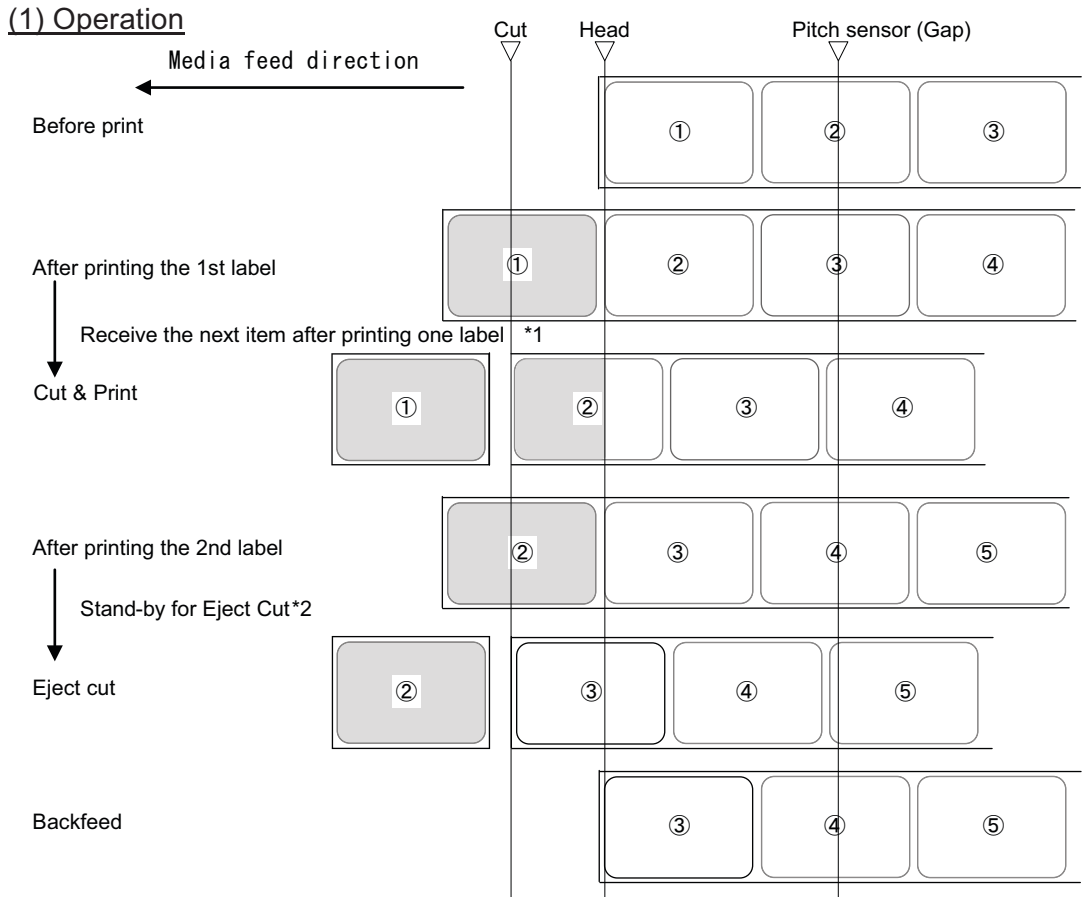

\*1 When the next print data is received after the first label is printed, the product prints the next data and cut the first one when it reaches the cut position.  
 \*2 If there is no data received after the print operation, and when the eject cut standby time is expired, eject cut is performed.  
 (Note)  
 • The base position using the Gap sensor is shown above.

#### (2) Timing chart

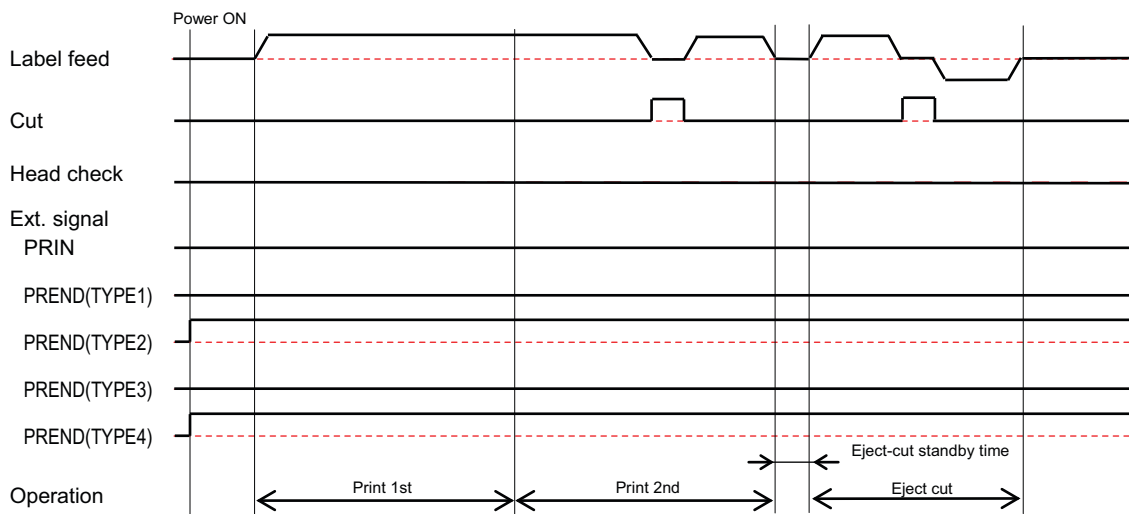

**8.7.13 No Pulse Input in Motion 3 Cutter Mode (Head Check Enabled)**

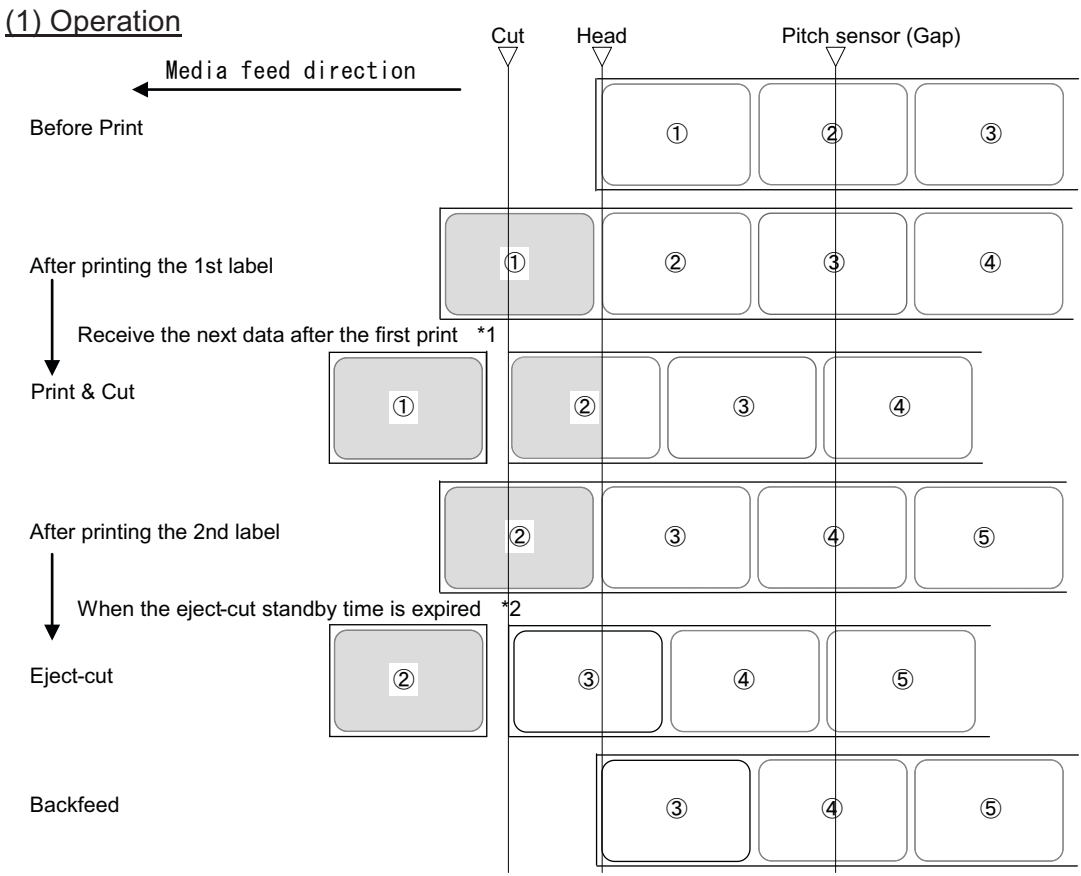

\*1 When the next print data is received after the first label is printed, the product prints the next data and cut the first one when it reaches the cut position.

\*2 If there is no data received after the print operation, and when the eject cut standby time is expired, eject cut is performed.

(Note)

- The base position using the Gap sensor is shown above.

**(2) Timing chart**

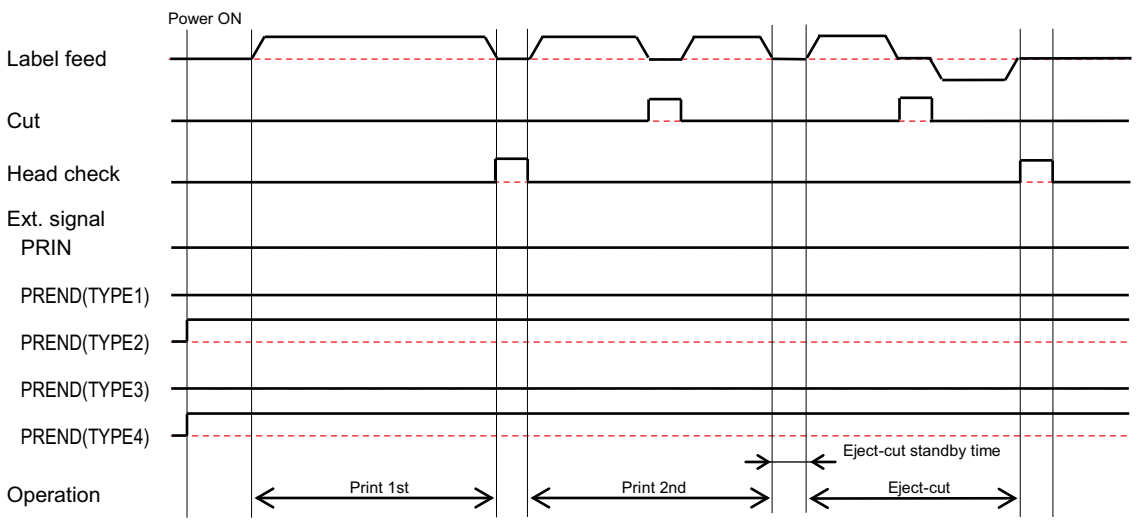

## 8.7.14 No Backfeed and With Pulse Input in Cutter Mode

### (1) Operation

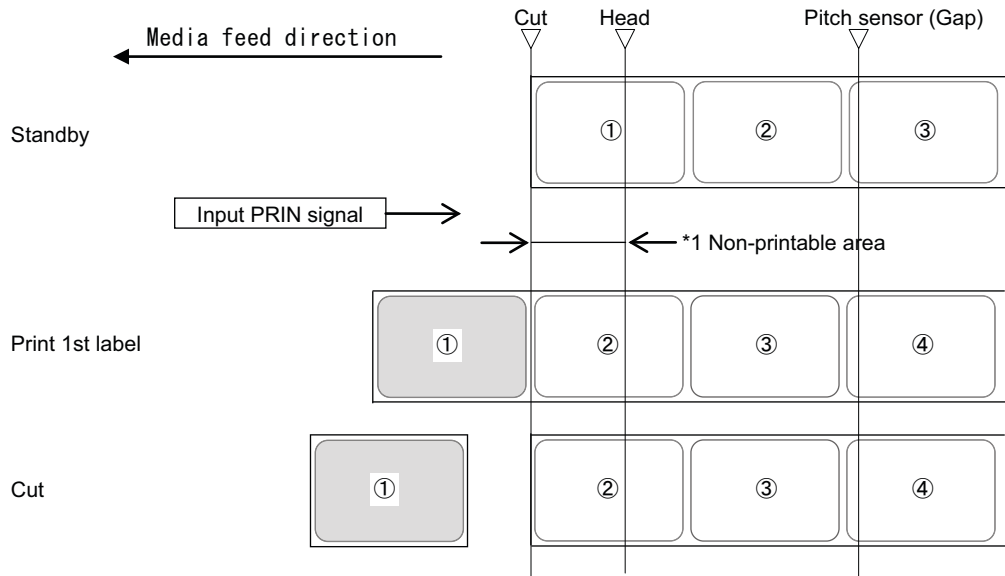

\*1 No backfeed is performed in this mode, thus some area will be left non-printable (Note)

- The base position using the Gap sensor is shown above.

### (2) Timing chart

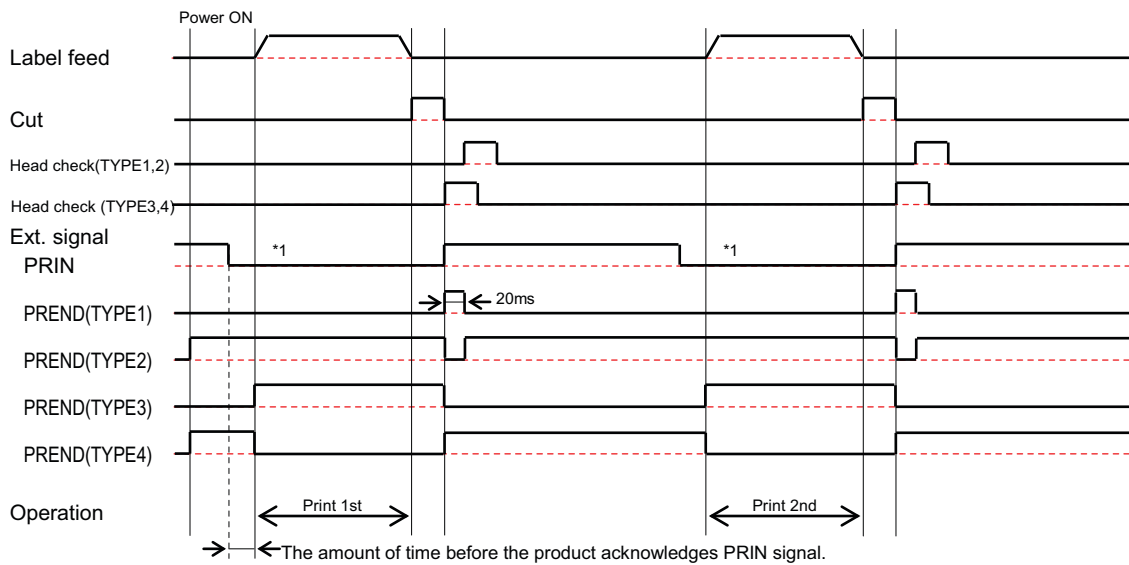

\*1. Retain PRIN until PREND is output.

## 8.7.15 With Pulse Input in Motion 1 Cutter Mode

### (1) Operation

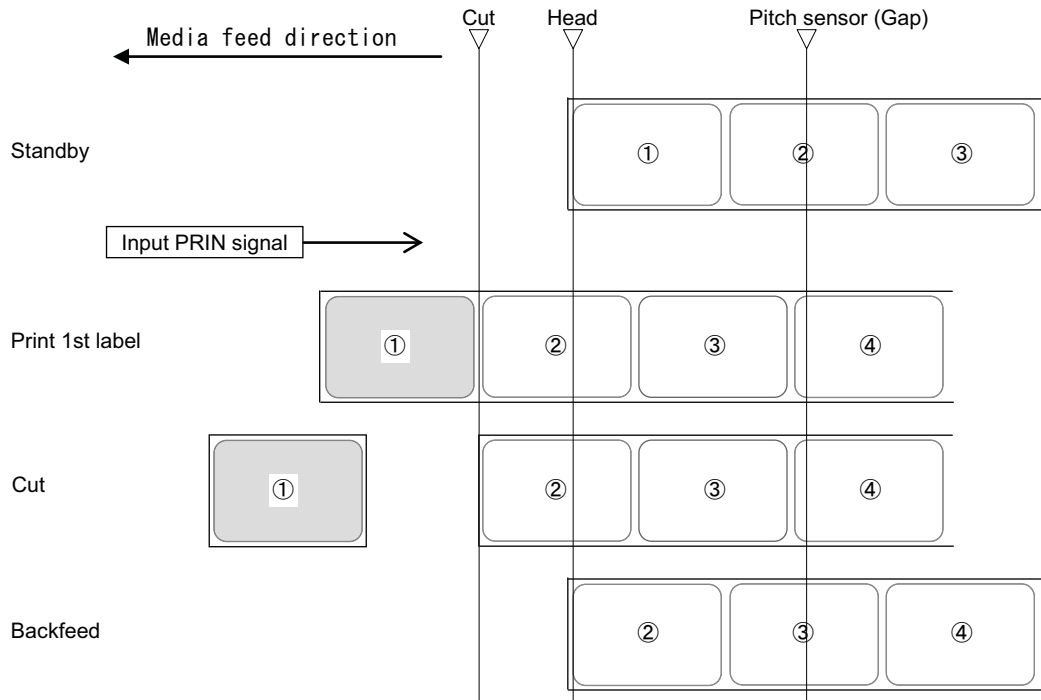

(Note)  
 • The base position using the Gap sensor is shown above.

### (2) Timing chart

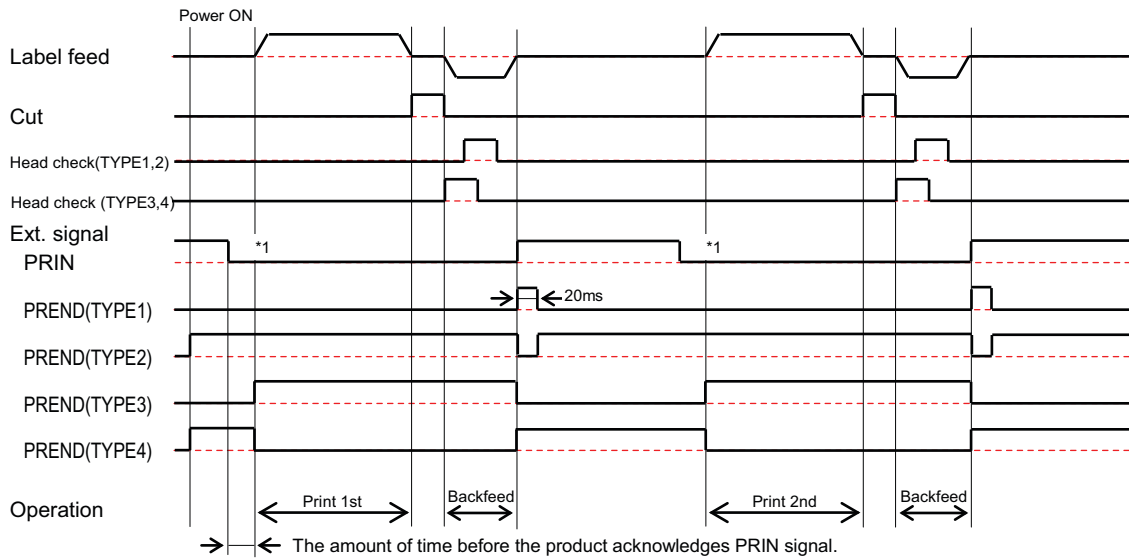

\*1. Retain PRIN until PREND is output.

## 8.7.16 With Pulse Input in Motion 2 Cutter Mode

### (1) Operation

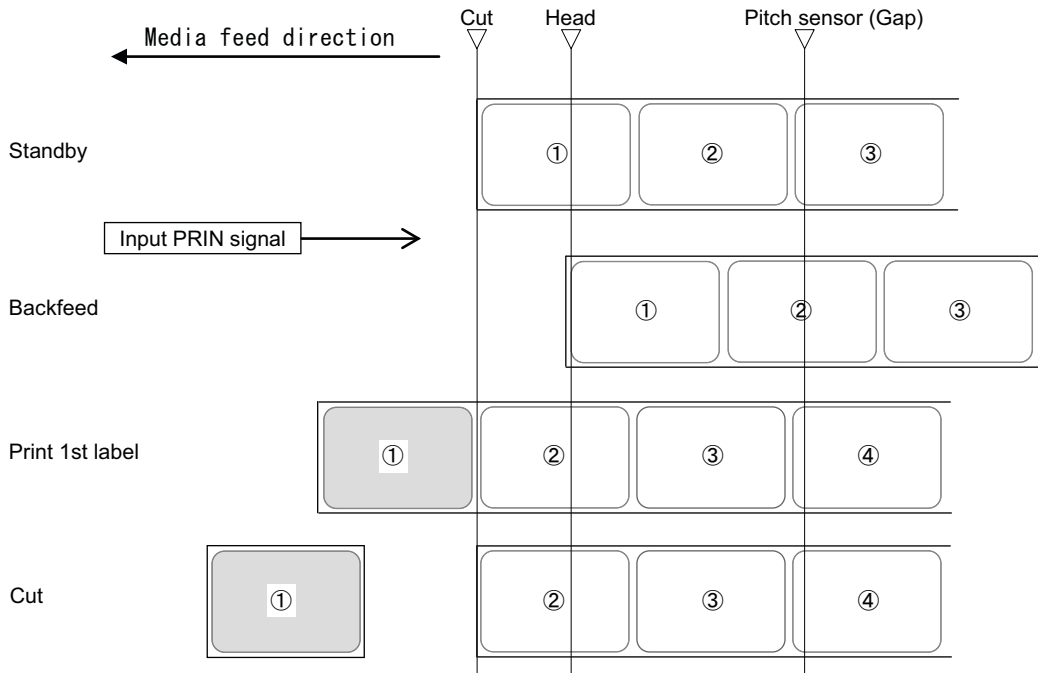

(Note)

- The base position using the Gap sensor is shown above.

### (2) Timing chart

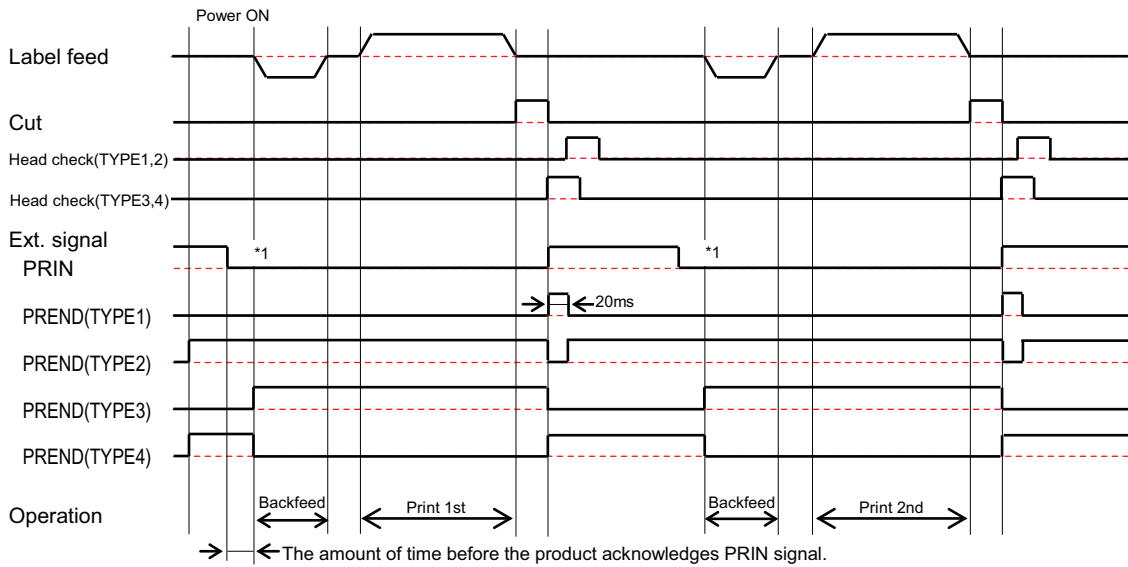

\*1. Retain PRIN until PREND is output.



### 8.7.17 When Sensor is Disabled

When the media sensor is disabled, the product stops at the specified print end position.

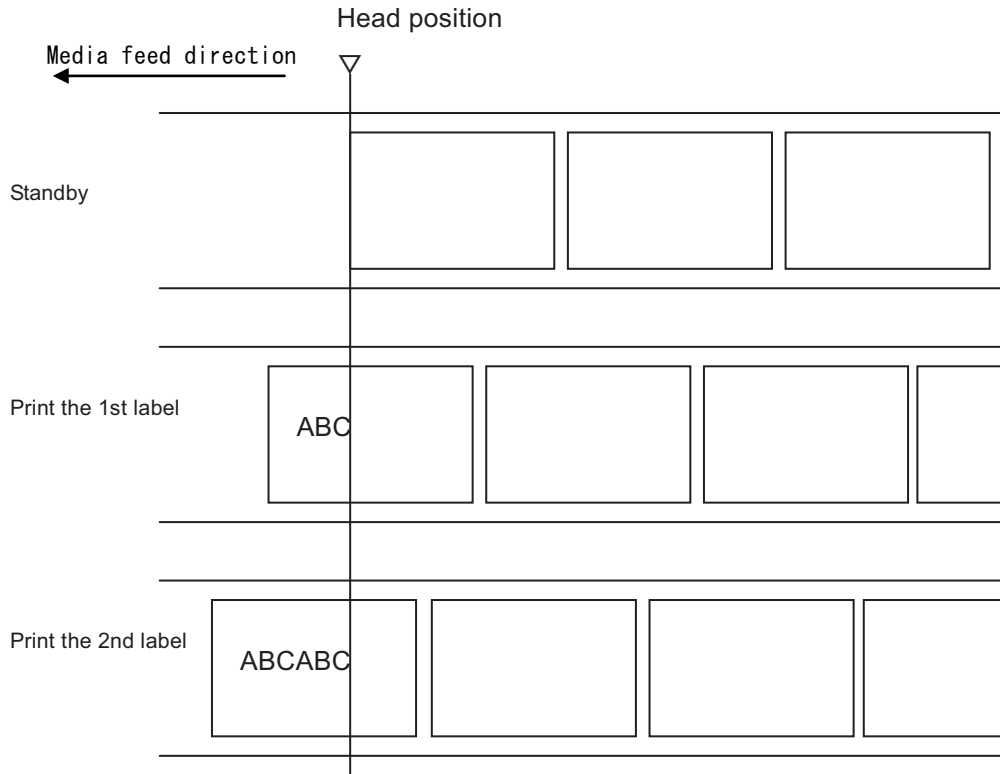

#### Note

The minimum media size varies with the print speed that controls the number of steps to accelerate/ decelerate the motor.

Print Speed	Minimum media size (mm)
2 inches/sec	10
3 inches/sec	10
4 inches/sec	10
5 inches/sec	10
6 inches/sec	15

### 8.7.18 Additional Notes on Motion 3 Cutting Operation

- The product stops to perform a cutting operation during a print job, which causes a white streak\* in the area (approx.  $36.2 \pm 1.5$  mm from the cut position) where the print head pauses.

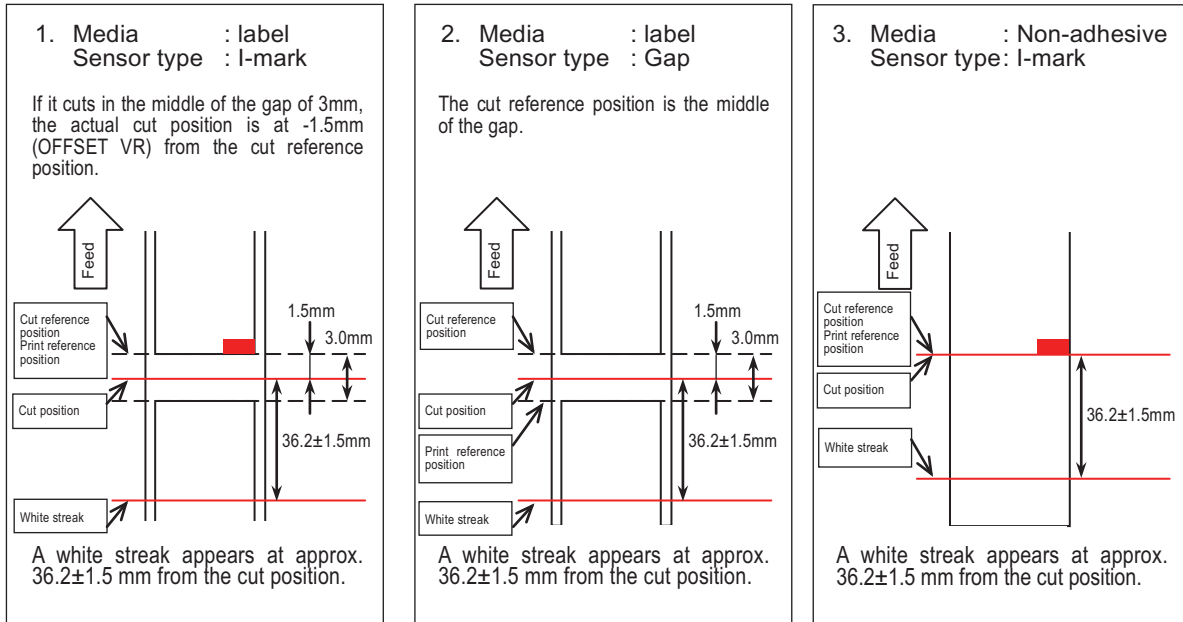

- Barcode serial 1/2 (90/270 degree rotation) are not allowed.
- The print layout with two QR code finder patterns in the above mentioned print head position is not allowed.

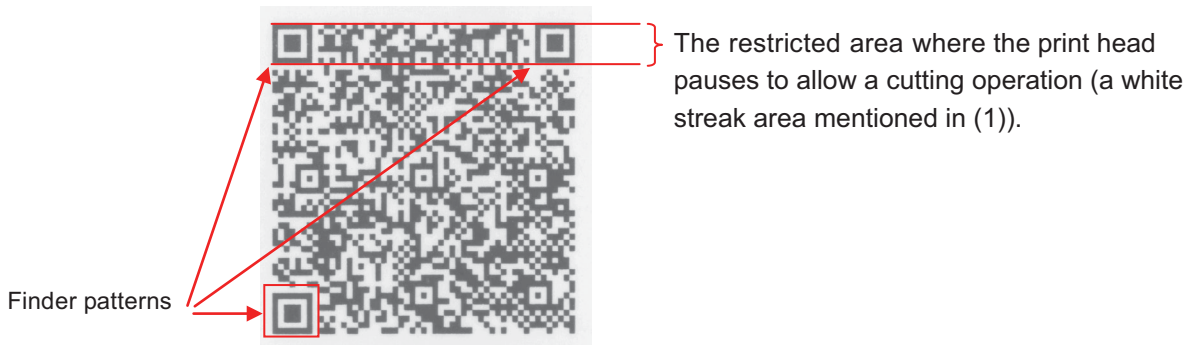

- The minimum size (width/height) of QR module may not be read correctly; four dots or more is recommended.
- The print layout with a 2-D code other than a QR code in the above mentioned print head position is not allowed.
- The minimum media length for the Motion 3 with cutter is 55mm (\*). The minimum length (40mm) remains the same for other operations. The longer length is required because Motion 3 with cutter prints (feeds) media after cutting operation.

(\*) The minimum length is calculated by the following formula:

- The distance between the thermal head and cutter: 36.2 mm
- Acceleration/deceleration distance (6 ips/61 steps: longest): 10.2 mm
- Offset Correction: 3.75 mm
- Margin: 5 mm

The minimum media length for the Motion 3 with Cutter = (i) + (ii) + (iii) + (iv) = 55.15 mm  $\approx$  **55 mm**

## 8.8 Product Specifications

Specifications are subject to change without notice.

### 8.8.1 Hardware

Dimensions and Weight	
Width	475 mm (18.7")
Height	320 mm (12.6")
Depth	314 mm (12.3")
Weight	Approximately 23 kg (50.7 lbs.)
Power Supply	
Input Voltage	AC 100 V - 240 V $\pm$ 10%
Frequency	50 - 60 Hz
Power Consumption	At peak: 413 VA / 404 W (Print ratio 30%, darkness: 10, print speed: 6 inch/sec) Standby: 28 VA / 24 W Input voltage condition: AC 100 V, 50 Hz
Processing	
CPU	32 Bit RISC-CPU 250 MHz
Flash ROM	40 MB (User area: 4.5 MB)
SDRAM	64 MB
Receive Buffer	Maximum: 2.95 MB Near full: 2 MB, Release: 1 MB
External Memory	SD card: Maximum 2 GB SDHC card: Minimum 4 GB - Maximum 32 GB USB flash memory: Maximum 32 GB
Operation	
LCD	Graphic LCD (Horizontal 128 dots X Vertical 64 dots) with backlight (White/orange switchable)
LED	POWER: Green ON LINE: Green STATUS: Green/Red LABEL: Red RIBBON: Red
Environmental Conditions (Without Media and Ribbon)	
Operating Temperature	5 to 40 °C (41 to 104 °F)
Storage Temperature	-5 to 60 °C (23 to 140 °F)
Operating Humidity	30 to 80% RH (Non-condensing)
Storage Humidity	30 to 90% RH (Non-condensing)

<b>Print</b>	
Print Method	Direct thermal and thermal transfer
Print Speed	75, 100, 125, 150 mm/sec (3, 4, 5, 6 inches/sec)
Resolution	305 dpi (12 dots/mm)
Non-printable Area	Pitch direction (Excludes liner) Top: 1.5 mm (0.06"), Bottom: 1.5 mm (0.06") Width direction (Excludes liner) Left: 1.5 mm (0.06"), Right: 1.5 mm (0.06")
Printable Area	Maximum Length 420 mm (16.5") x Width 266.7 mm (10.5")
Print Darkness	Darkness level: 1 to 10
<b>Sensors</b>	
I-mark (Reflective Type)	Sensitivity: Adjustable
Gap (Transmissive Type)	Sensitivity: Adjustable
Head Open	Fixed
Cutter cover	Fixed
Label End Sensor	Sensitivity: Adjustable
Ribbon End Sensor	Fixed

## 8.8.2 Ribbon and Media

<b>Ribbon</b> (Use consumables from our specified suppliers.)	
Size	Width: 145 mm to 273 mm (5.7" to 10.7") Length: Maximum 300 m (984.25 ft.)
Wind Direction	Face-in
Roll Diameter	Maximum 70 mm
Core Diameter	33.6 ±0.4 mm

<b>Media</b> (Use consumables from our specified suppliers.)	
Type	<p>Fan-fold media</p> <ul style="list-style-type: none"> <li>Maximum stack height: 100 mm (3.9") from the surface on which the product rests. The maximum stack height above may not apply depending on where the media is set.</li> </ul> <p>Media roll</p> <ul style="list-style-type: none"> <li>Maximum roll diameter: 200 mm (8")</li> <li>Core diameter: 76 mm (3")</li> <li>Use an optional unwinder (UWG112) for this media type.</li> </ul>

<b>Media</b> (Use consumables from our specified suppliers.)	
Size	
Continuous Mode	
Pitch (With Liner)	30 to 420 mm (1.2" to 16.5") 33 to 423 mm (1.3" to 16.6")
Width (With Liner)	128 to 297 mm (5.0" to 11.7") 131 to 300 mm (5.2" to 11.8")
Tear-off Mode	
Pitch (With Liner)	40 to 420 mm (1.6" to 16.5") 43 to 423 mm (1.7" to 16.6")
Width (With Liner)	128 to 297 mm (5.0" to 11.7") 131 to 300 mm (5.2" to 11.8")
Cutter Mode	
Pitch (With Liner)	40 to 420 mm (1.6" to 16.5") 43 to 423 mm (1.7" to 16.6")
Width (With Liner)	128 to 297 mm (5.0" to 11.7") 131 to 300 mm (5.2" to 11.8")
Media Tray	
Pitch (With Liner)	40 to 117 mm (1.6" to 16.5") 43 to 120 mm (1.7" to 16.6")
Width (With Liner)	128 to 297 mm (5.0" to 11.7") 131 to 300 mm (5.2" to 11.8")
Maximum stack height: 5 mm (0.2") (approx. 40 sheets, 0.12 mm (0.008") thick/sheet)	
<b>Note</b> When <b>DISABLE</b> is selected in <b>PITCH SENSOR</b> , the minimum label size varies depending on the print speed. Refer to <a href="#">Section 8.7.17 When Sensor is Disabled</a> for details.	
Thickness (Label and liner)	Cut: 0.08 to 0.21 mm (0.003" to 0.008") Feed: 0.08 to 0.27 mm (0.003" to 0.01"), use media with thickness of 0.12 mm (0.005") or greater for auto feed function.

### 8.8.3 Interface

<b>Interface</b>	
Standard	USB Interface (Type B) LAN Interface RS-232C Interface IEEE1284 Interface External Signal Interface (EXT) SD card slot USB Host (Type A)

## 8.8.4 Built-in Functions

Functions	
Built-in Functions	Status return Graphic Sequential number Form overlay External font registration Character modification Black/white inversion Ruled line Format registration Zero slash switching JIS/Shift JIS/Unicode (UTF-8/UTF-16) switching Dump list (Hex dump mode) Outline font Outline transformation Arc function (Print text in arc shape) Auto feed
Self-diagnosis Functions	Broken head element check Head open detection Paper end detection Ribbon end detection Ribbon near-end detection Test print Kanji data check Cutter error
Adjustment Functions	Print darkness Print position Media stop position Buzzer volume LCD brightness
Protective Functions	Head overheating protection function Power supply temperature monitor function

## 8.8.5 Printer Languages

Printer Languages
SBPL (SATO Barcode Printer Language)

## 8.8.6 Fonts/Symbols/Barcodes

Fonts	
Bitmap Fonts	
X20	9 dots H x 5 dots W (Alphanumeric, symbols, kana)
X21	17 dots H x 17 dots W (Alphanumeric, symbols, kana)
X22	24 dots H x 24 dots W (Alphanumeric, symbols, kana)
X23	48 dots H x 48 dots W (Alphanumeric, symbols, kana)
X24	48 dots H x 48 dots W (Alphanumeric, symbols, kana)
XU	9 dots H x 5 dots W (Alphanumeric, symbols)
XS	17 dots H x 17 dots W (Alphanumeric, symbols)
XM	24 dots H x 24 dots W (Alphanumeric, symbols)
XB	48 dots H x 48 dots W (Alphanumeric, symbols)
XL	48 dots H x 48 dots W (Alphanumeric, symbols)
OCR-A	33 dots H x 22 dots W (Alphanumeric, symbols)
OCR-B	36 dots H x 30 dots W (Alphanumeric, symbols)
Japanese Fonts (Ryobi)	Kanji 16 dots H x 16 dots W (JISX0208 - compliant) Mincho/Gothic Kanji 22 dots H x 22 dots W (JISX0208 - compliant) Mincho/Gothic Kanji 24 dots H x 24 dots W (JISX0208 - compliant) Mincho/Gothic Kanji 32 dots H x 32 dots W (JISX0208 - compliant) Mincho/Gothic Kanji 40 dots H x 40 dots W (JISX0208 - compliant) Mincho/Gothic  JIS Level 1/2
Simplified Chinese Characters (GB18030)	Mincho 16 dots H x 16 dots W 24 dots H x 24 dots W Gothic 24 dots H x 24 dots W
Traditional Chinese Characters (BIG5)	Mincho 24 dots H x 24 dots W
Scalable Fonts	
Rasterized Font	CG Times (Alphanumeric, symbols) CG Triumvirate (Alphanumeric, symbols) *Support Codepage 858, Bold/Italic
	SATO Gamma SATO Vica * Support WGL4
Outline Fonts	Kanji (JIS Level 1/2), Alphanumeric, Symbols, Kana
Extended Fonts	Font downloaded data

Barcodes	
1D Barcodes	UPC-A/UPC-E JAN/EAN-13/8 CODE39, CODE93, CODE128 GS1-128(UCC/EAN128) ISBT128 CODABAR(NW-7) ITF Industrial 2 of 5 Matrix 2 of 5 MSI POSTNET BOOKLAND GS1 DataBar Omnidirectional GS1 DataBar Truncated GS1 DataBar Stacked GS1 DataBar Stacked Omnidirectional GS1 DataBar Limited GS1 DataBar Expanded GS1 DataBar Expanded Stacked *GS1 DataBar is formerly called RSS. Intelligent Mail Barcode (IMB)
2D Codes	QR Code (including Micro QR) PDF417 (including Micro PDF) MAXI Code (Ver.3.0) GS1 Data Matrix (ECC200 Ver.2.0)
Composite Symbols	EAN-13 Composite (CC-A/CC-B) EAN-8 Composite (CC-A/CC-B) UPC-A Composite (CC-A/CC-B) UPC-E Composite (CC-A/CC-B) GS1 DataBar Composite (CC-A/CC-B) GS1 DataBar Truncated Composite (CC-A/CC-B) GS1 DataBar Stacked Composite (CC-A/CC-B) GS1 DataBar Expanded Stacked Composite (CC-A/CC-B) GS1 DataBar Expanded Composite (CC-A/CC-B) GS1 DataBar Stacked Omnidirectional Composite (CC-A/CC-B) GS1 DataBar Limited Composite (CC-A/CC-B) GS1-128 Composite (CC-A/CC-B/CC-C)

Controls	
Rotation	Characters: 0°, 90°, 180°, 270° Barcode: Parallel 1 (0°), Parallel 2 (180°), Serial 1 (90°), Serial 2 (270°)
Barcode Ratio	1:2, 1:3, 2:5, Any ratio is available
Magnification	Bitmap font: Vertical 1 to 12, Horizontal 1 to 12 Barcode: 2 to 12



## 8.8.7 Options

Options	
	1) Real-time clock kit (Calendar) 2) Stacker (STG112) 3) Unwinder (UWG112)

## 8.8.8 Accessories

Accessories	
	1) Power cord* (*The power cord is not supplied depending on the region.) 2) User documents (Quick guide, Safety instructions, Global Warranty Program leaflet, etc.) 3) Ribbon core

## 8.8.9 Standards

Standards	
Safety Standards	UL60950-1, CSA22.2, EN60950-1, BIS, CCC, BSMI
EMC Standards	FCC Part15 Subpart B, ICES-003, EN55024, EN55032, CCC, BSMI
Environmental Standard RoHS	This product is in conformity with <b>RoHS Directive 2011/65/EU</b> on the Restriction of the Use of Certain Hazardous Substances in Electrical and Electronic Equipment.

## 8.9 Interface Specifications

For data communication with the host, this product supports the following interfaces:  
You can set the various interface settings of the product through the **Interface Mode** menu.

- USB Interface (Type B)
- LAN Interface (10BASE-T/100BASE-TX automatic switch over, RJ45 connector)
- RS-232C Interface (DSUB 9 pins, female)
- IEEE1284 Interface (Amphenol 36 pins, female)
- External signal (EXT) Interface (Amphenol 14 pins, female)
- USB Host (Type A)

---

### CAUTION

Do not connect or disconnect the interface cables (or use a switch box) with power supplied to either the product or host. This may cause damage to the interface circuitry in the product or host and is not covered by warranty.

---

## 8.9.1 USB Interface

This interface complies with the USB2.0 standard.  
Install the USB driver to the computer before use.

Basic Specifications	
Connector	USB Type B connector
Protocol	Status4, Status5
Power Supply	BUS Power through cable
Version	USB 2.0 High speed

Pin Assignments	
Pin No.	Description
1	VBus
2	-Data
3	+Data
4	GND

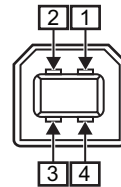

Cable Specifications	
Cable Connector	USB Type B connector
Cable Length	5 m (16.4 feet) or less

## 8.9.2 LAN Interface

Basic Specifications (When IPv4 is selected)	
Connector	RJ-45 Receptacle
Power Supply	Powered from the product
Protocol	Status3 Status4 (Cyclic response mode) Status4 (ENQ response mode) Status5
IP Address	0.0.0.0 - 255.255.255.255 Initial: 192.168.1.1
Subnet Mask	0.0.0.0 - 255.255.255.255 Initial: 255.255.255.0
Gateway Address	0.0.0.0 - 255.255.255.255 Initial: 0.0.0.0

Basic Specifications (When IPv6 is selected)	
Connector	RJ-45 Receptacle
Power Supply	Powered from the product
Protocol	Status3 Status4 (Cyclic response mode) Status4 (ENQ response mode) Status5
IP Address	0000:0000:0000:0000:0000:0000:0000:0000 - FFFF:FFFF:FFFF:FFFF:FFFF:FFFF:FFFF:FFFF Initial: 0000:0000:0000:0000:0000:0000:0000:0000
Prefix	0 -128 Initial: 64
Default Router	0000:0000:0000:0000:0000:0000:0000:0000 - FFFF:FFFF:FFFF:FFFF:FFFF:FFFF:FFFF:FFFF Initial: 0000:0000:0000:0000:0000:0000:0000:0000

Link/Status LED		
LED	Color	Description
LED1	Green	LED lights up for 10 ms when packets are received. LED lights up when the product established the LINK with Ethernet device.
LED2	Orange	LED lights off when the product detected the connection to 10BASE-T.
		LED lights up when the product detected the connection to 100BASE-TX.
		LED lights up when a cable is not connected.

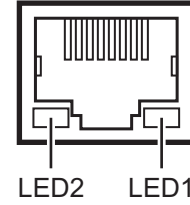

Cable Specifications	
Cable	10BASE-T/100BASE-TX Category 5 or upper
Cable Length	100 m (328 feet) or less

Software Specifications	
Supported Protocol	TCP/IP
Network Layer	ARP, RARP, IP, ICMP
Session Layer	TCP, UDP
Application Layer	LPD, FTP, TELNET, BOOTP, DHCP, HTTP, SNMP, SNTP

### 8.9.3 RS-232C Interface

This interface complies with the RS-232C standard.

Basic Specifications	
Synchronization system	Asynchronous communication
Data Transmission Rate	2400, 4800, 9600, 19200 (default), 38400, 57600, 115200 bps
Transmission Form	Start, b1, b2, b3, b4, b5, b6, b7, b8, Stop "b8" will be omitted if using 7 bit oriented.
Data Length	7 or 8 bits (default)
Stop Bit	1 (default) or 2 bits
Parity Bit	ODD, EVEN, NONE (default)
Codes Used	ASCII Character Codes: 7 bits, Graphics: 8 bits
Connector	DB-9 Female or equivalent
Signal Levels	High = +5 to +12 V, Low = -5 to -12 V
Protocol	Ready/Busy, XON/XOFF, Status3, Status4 (default), Status5

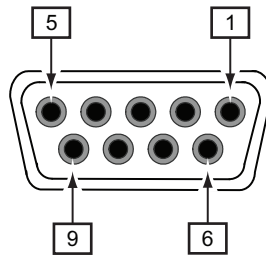

Connector Pin Specifications			
Pin No.	I/O	Signal Name	Description
1	-	CD	Data Carrier Detect
2	Input	RD	Receive Data
3	Output	SD	Transmit Data
4	Output	ER	Data Terminal Ready
5	Reference	SG	Signal Ground
6	Input	DR	Data Set Ready
7	Output	RS	Request To Send
8	Input	CS	Clear To Send
9	-	-	Not connected

<b>Cable Specifications</b>	
Cable Connector	DB-9 Male or equivalent
Cable Length	5 m (16.4 feet) or less

Connecting diagram of DB-9 cable

<b>Product</b>		<b>Host</b>	
CD	1	1	CD
RD	2	3	SD
SD	3	2	RD
ER	4	6	DR
SG	5	5	SG
DR	6	4	ER
RS	7	8	CS
CS	8	7	RS

### 8.9.4 IEEE1284 Interface

This interface complies with the IEEE1284 standard.

Basic Specifications	
Connector	Amphenol 36 pins, female
Signal Levels	High-level: +2.4 to +5.0 V Low-level: +0.0 to +0.4 V
Receive Mode	Single-item buffer, Multi-item buffer
Protocol	Status4, Status5

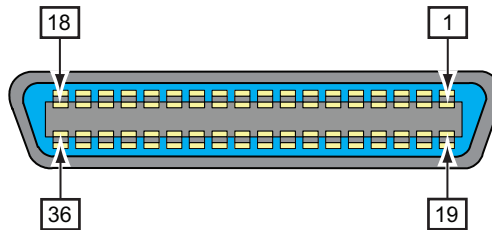

Connector Pin Specifications		
Pin No.	I/O	Description
1	Input	STROBE
2-9	Input	DATA 1 - DATA 8 DATA1: LSB DATA8: MSB
10	Output	ACK
11	Output	BUSY
12	Output	PAPER EMPTY/PAPER ERROR
13	Output	SELECT
14	Input	AUTO FEED
15	-	Not in use
16	-	LOGIC Ground
17	-	Frame Ground
18	-	+5 V
19	-	STROBE RETURN
20-27	-	DATA 1 - DATA 8 RETURN
28	-	ACK RETURN
29	-	BUSY RETURN
30	-	PAPER EMPTY RETURN



---

<b>Connector Pin Specifications</b>		
<b>Pin No.</b>	<b>I/O</b>	<b>Description</b>
31	Input	INITIALIZE
32	Output	FAULT
33-35	-	Not in use
36	Input	SELECT INPUT

<b>Cable Specifications</b>	
Cable Connector	Amphenol 36 pins, male
Cable Length	1.5 m (5 feet) or less

### 8.9.5 External Signal Interface (EXT)

This interface is designed to connect the product with other peripherals.

#### Basic Specifications

Connector	Amphenol 14 pins, female
Signal Levels	High-level: +4.2 to +5.0 V Low-level: +0.0 to +0.7 V

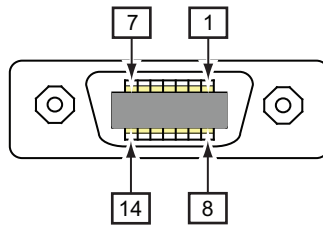

#### Connector Pin Specifications

Pin No.	I/O	Description
1	Output	Paper End: Outputs a low signal when the paper end is detected.
2	-	GND: Reference Signal Ground
3	Output	Ribbon End: Outputs a low signal when the ribbon end is detected.
4	Output	Machine Error: Outputs a low signal when an error such as the head open error is detected.
5	Input	Print start signal (PRIN): Prints one media when a low signal is detected.
6	Output	Print Done/Print end signal (PREND): Outputs a low signal when the media print is completed.
7	Input	Reprint signal (PRIN2): Prints the previously printed content again when a low signal is detected.
8	Input	External power supply: 5 V
9	Output	Online/Offline: Outputs a low signal when the product is in offline mode.
10	Output	Ribbon Near End: Outputs a high signal when the ribbon near end is detected.
11	-	-
12	-	+24 V $\pm$ 10%
13	-	Vcc +5 V
14	-	-

## Note

- You can set the external signal type (TYPE1 to TYPE4) for PREND output signal of pin No. 6. Refer to the **EXTERNAL SIGNAL** screen of the **Advanced Mode** menu for details.
- The Print Done/Print end signal of pin No. 6 is not output when "0" is specified in the number of cuts in the command specifying the number of cuts during the cutting operation.

## Input/output circuit diagram of 14-pin external signal interface (Amphenol 14 pins, female connector)

14 pin type

An example of input/ output connection

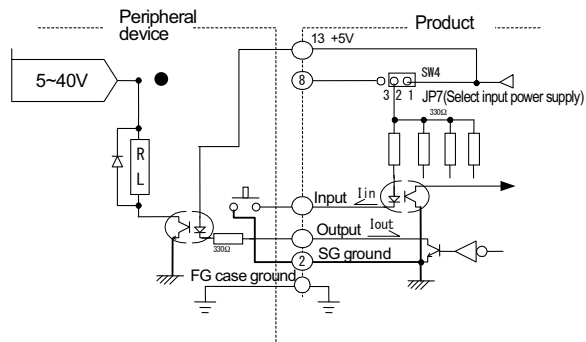

### Timing Chart of the EXT Input Signal

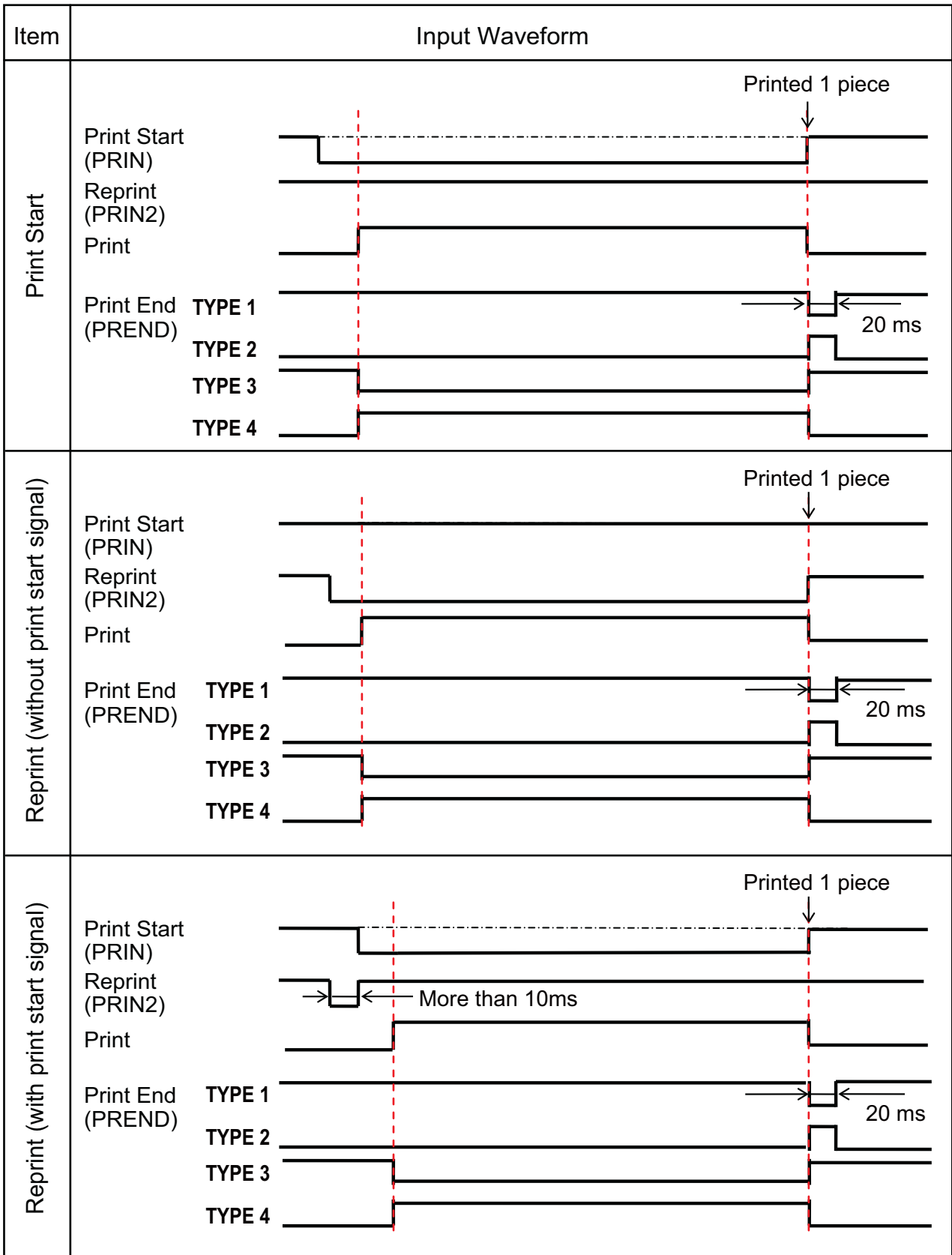

**Supplementary explanation**

- 1 Keep the print start signal (PRIN) to “Low” until print end signal (PREND) is outputted. For maintaining the print start signal (PRIN), refer to the **Maintaining the Print Start Signal (PRIN)** timing chart. Keep the output reprint signal (PRIN2) for more than 10 ms. When signal is outputted for shorter than 10 ms, and reprint signal is not acknowledged, the product does not perform reprinting.

**Maintaining the Print Start Signal (PRIN)**

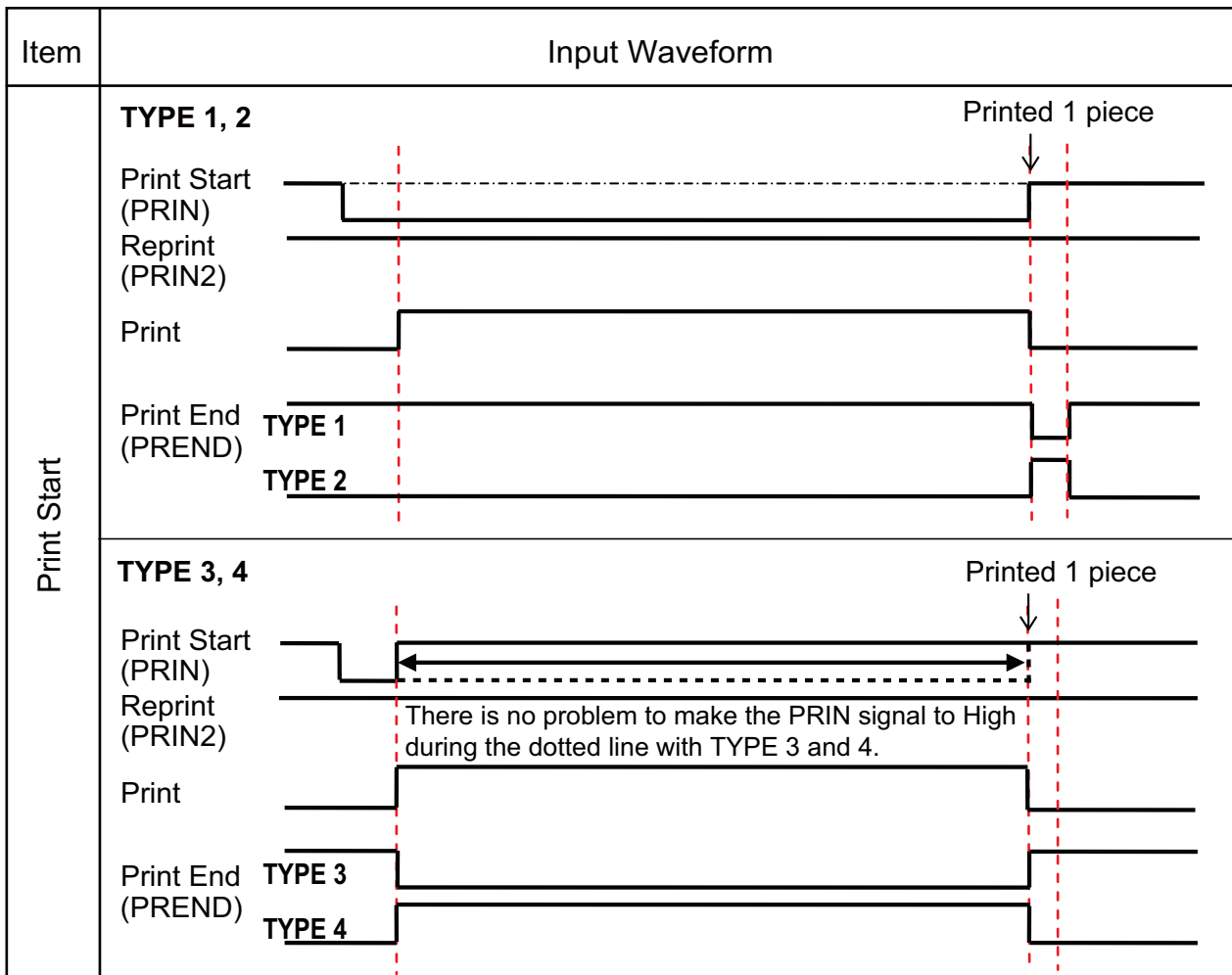

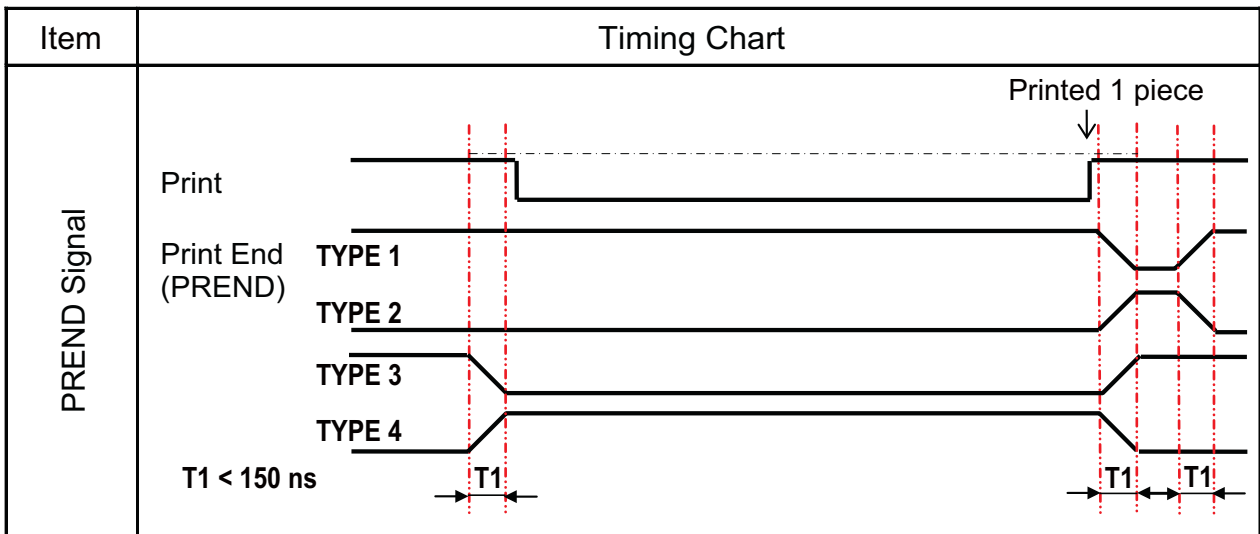

Rise or fall time (T1) of PREND signal is less than 150ns. You have to consider the time when outputting the signal from the connected devices.

- 2 When the print start signal and reprint signal are output simultaneously, the print start signal is enabled and the product does not perform reprinting.
- 3 The reprint signal is valid only from the time of the print operation end (QTY=0) until the next print data reception. Other than that, the product does not perform reprinting.

### Timing Chart of the EXT Output Signal

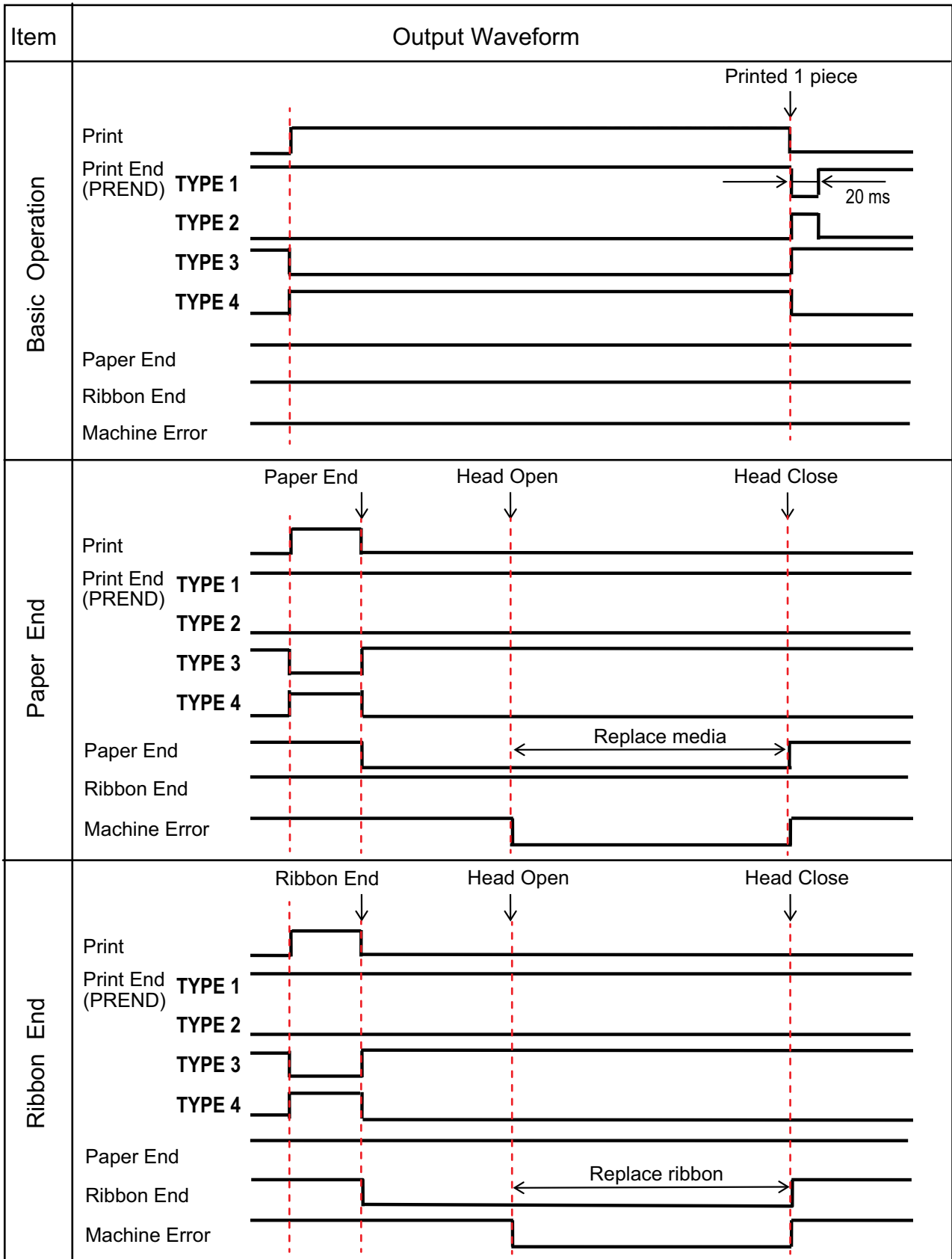

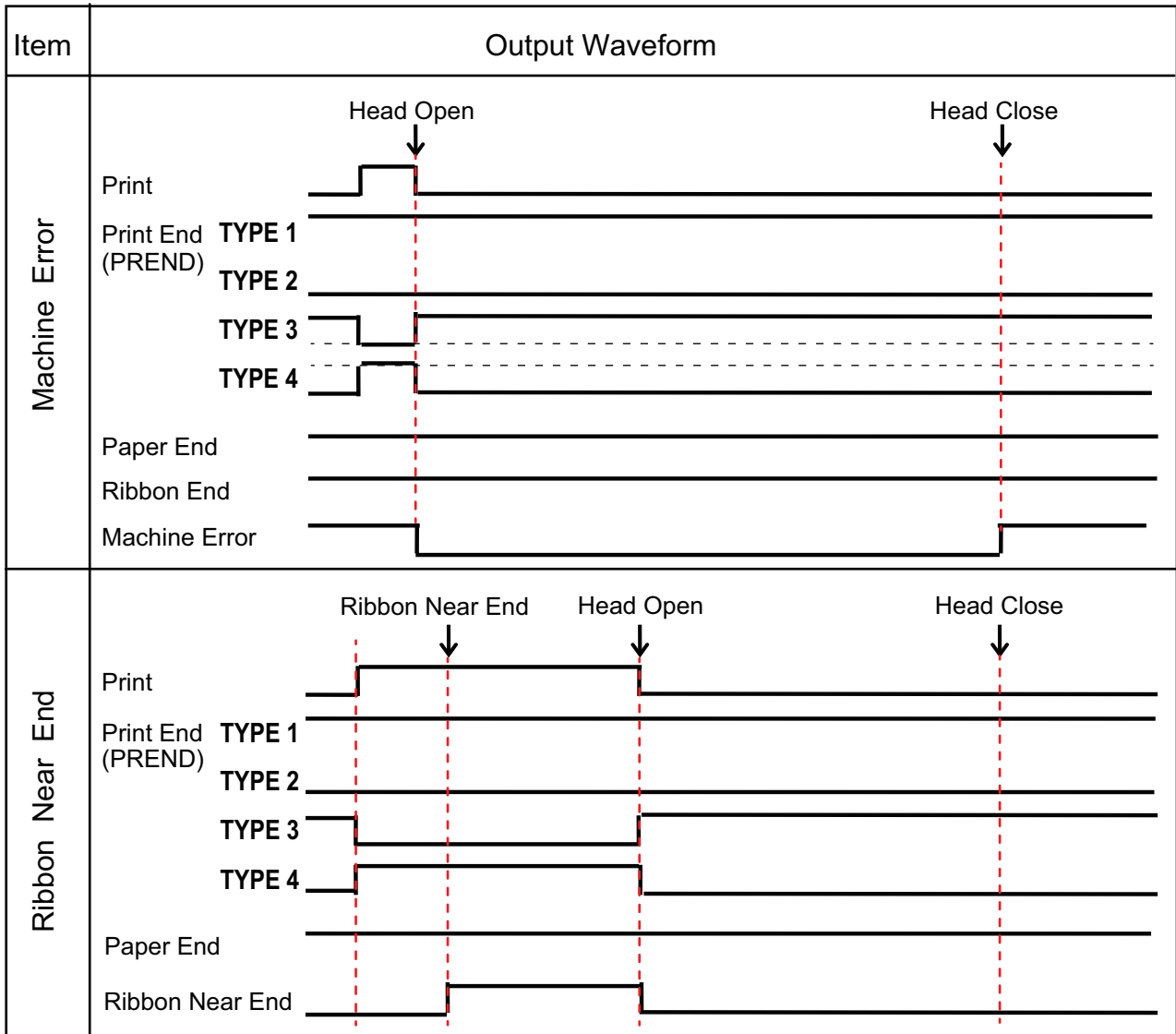



## 8.9.6 USB Host

This interface complies with the USB2.0 standard.

Basic Specifications	
Connector	USB Type A connector
Version	USB 2.0 High speed
Device class	Mass storage class
Application	USB memory

Pin Assignments	
Pin No.	Description
1	VBus
2	-Data
3	+Data
4	GND

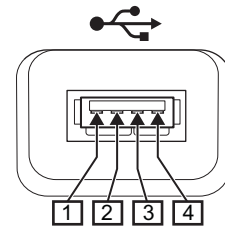



Extensive contact information for worldwide  
SATO operations can be found on the Internet at  
**[www.satoworldwide.com](http://www.satoworldwide.com)**

**SATO**